

## The action of vitamin D on the degree of mineralization of bone tissue in rats given adequate amounts of calcium and phosphorus in the diet

### A microradiographic study

BY P. RASMUSSEN

*Department of Anatomy, Dental Faculty, University of Oslo*

*(Received 18 January 1969—Accepted 18 August 1969)*

1. The action of vitamin D on the degree of mineralization of the bone tissue of rats given a diet containing adequate amounts of calcium and phosphorus for 8 weeks has been investigated by quantitative microradiography. The method is described.
2. There was a significant reduction in the growth of the vitamin D-deficient rats; the reduction was most marked in the females.
3. Serum analysis showed a reduction in Ca, but P was unchanged. However, the Ca × P product was considered to be high enough to permit normal mineralization.
4. The degree of mineralization of the cortical bone tissue increased significantly according to the distance from the epiphyseal plate. However, there were no significant differences between vitamin D-treated and vitamin D-deficient animals.
5. It is concluded that vitamin D deficiency in rats does not prevent the formation of a bone matrix which can attain a normal degree of mineralization.

Numerous investigations have been made to determine the degree of mineralization (mineral content) in the bones of animals fed diets with varying contents of calcium and phosphorus, and with a varying content of vitamin D. Most authors have applied conventional chemical methods for analysis based on bones dried to constant weight, with or without previous fat extraction. The bones are normally ashed at about 600° and the percentage of ash in the dry, fat-free bones is calculated. This method of analysis has some weaknesses, in particular that the ash contents of bones as total organs are determined. However, even after fat extraction and drying to constant weight, there are substances in the bone marrow and vascular channels which are not true bone tissue. For instance in a case of rickets, there is an increase in cartilage and osteoid which contributes to the dry weight; the true degree of mineralization of the bone tissue is therefore underestimated.

A better method of analysis would be to take out small volumes of well-defined bone tissue and to determine the mineral content of these without previous dehydration and ashing. This can be done by dissecting out microvolumes from certain areas of the bone using a dissecting microscope and performing a traditional analysis on the small samples obtained. Strandh (1960) applied the method on osteons with different degrees of mineralization (as judged from microradiographs) and found good agreement between the degree of mineralization obtained by this method and by the microradiographic method.

A relatively new method for the determination of the mineral content of calcified tissues is that of quantitative microradiography. Despite the fact that the principles

of the method have been known since the discovery of X-rays, it is through the work of Engström and co-workers in Stockholm during the last 20 years that the method has reached a sufficiently high degree of perfection for it to be used as a method of quantitative analysis.

In most animals a vitamin D-deficient diet produces rickets. Besides morphological changes in the skeleton and changes in the levels of Ca or P, or of both, in the serum, a significant reduction in the mineral content of the bones is also found. This may be due to reduced growth, increased amounts of non-mineralized cartilage or an increase in osteoid, or of both. Another possible explanation for the reduced mineral content of the bones is that the bone tissue may have a lower degree of mineralization in cases of vitamin D deficiency.

The prevailing opinion as to the causes of skeletal changes in rickets is that they are secondary to the levels of Ca and P in the serum which results in a  $Ca \times P$  product below that necessary for normal mineralization. The possibility that vitamin D may have a direct action on bone at the site of ossification has not, however, been definitely disproved.

The purpose of the present investigation was to determine whether or not vitamin D has a direct effect on bone mineralization. For this reason rats were chosen as the experimental animals, because vitamin D deficiency in rats does not produce such great changes in serum Ca and P as in most other animals, provided that the contents of Ca and P in the diet are adequate. Changes in the degree of mineralization of the bone tissue in the vitamin D-deficient rats may therefore reflect a direct action of the vitamin on the mineralization process.

Quantitative microradiography was used to estimate the mineral content of the bone tissue.

#### MATERIALS AND METHODS

##### *Experimental animals and treatment*

The animals came from an inbred colony of white and hooded rats at Johan Throne Holst's Institute for Nutrition Research, University of Oslo. These have been maintained for more than 25 years on a diet containing very low amounts of vitamin D. The offspring of these rats develop severe rickets, as shown by the lack of roentgenologically visible epiphyseal calcification of the proximal end of the tibia, after consuming a rachitogenic (high Ca, low P) diet for 10–12 days from the time of weaning; this indicates a high degree of body depletion of vitamin D. Healing is obtained with as little 0.4–0.8 i.u. vitamin D daily for 12 days (Toverud, 1964).

Twenty-four rats were divided into two groups, each containing eight males and four females. The first group (vitamin D-treated) was given 40 i.u. ergocalciferol every 3rd day. The second group (vitamin D-deficient) was given a diet without any known source of vitamin D. The animals were kept in metabolism cages in a room without direct sunlight. The experimental period was 8 weeks (from weaning at 4 weeks to 12 weeks of age).

The vitamin D-deficient diet was a modification of Toverud's (1964) high-protein diet, with a higher content of Ca (1.11%) and P (0.8%), giving a weight ratio Ca:P

of 1.4 and an atomic ratio of 1.0. The salt and vitamin B mixtures added to the diet were those of Gran (1960a). Vitamin A (225 i.u.) was given to both groups every 3rd day. Both vitamins A and D were given perorally by pipette; great care was taken to avoid contamination of the vitamin D-deficient animals with any traces of this vitamin.

The animals were weighed every week during the experimental period. At the end of the experiment the animals were killed by ether and bled through the carotid artery. Ca analyses were carried out on duplicate or triplicate samples of serum according to Gran (1960b). The P analyses of the serum were carried out according to the method of Fiske & Subbarow (1925).

#### Microradiography

The left knee joint with half of the femur and half of the tibia was dissected free, fixed in buffered, neutral formalin, dehydrated in alcohol and embedded in plastic. After hardening, the specimens were cut in sections at about 200  $\mu\text{m}$  and ground to a

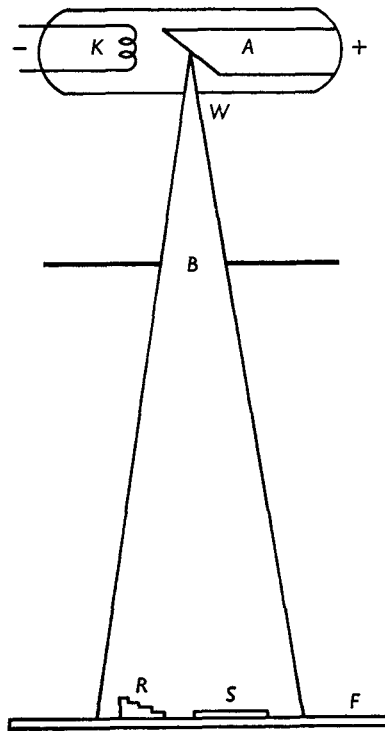

Fig. 1. Apparatus for contact microradiography. Anode (A), cathode (K), window with beryllium filter (W), aperture with nickel filter (B), reference system (R), section (S), and film (F).

thickness of about 100  $\mu\text{m}$  by the method of Frost (1958). The thickness of the section was measured at the point of quantitative microradiography with a Tesamaster Micrometer (Tesa S.A. Renens-VD, Switzerland) fitted with a vernier which enabled readings to be taken with an accuracy of 1  $\mu\text{m}$ .

The apparatus used for microradiography was a Philips PW X-ray Diffraction Unit

with a copper anode and an effective focal spot of  $0.4 \times 0.4 \text{ mm}^2$  (Fig. 1). It was operated at 20 kV and 20 mA. A nickel filter reduced the primary polychromatic radiation to an approximately monochromatic radiation of  $1.54 \text{ \AA}$ . The focus-film distance was 26 cm. Kodak Maximum Resolution Plates with a resolution of 1000 lines per mm were used. The film was exposed for 15 min, processed in Kodak D-11 for 5 min under constant stirring and fixed for 15 min. Before making the microradiographs, the field of X-rays was examined for homogeneity. The field was found to be homogeneous in one direction and inhomogeneous in the perpendicular direction.

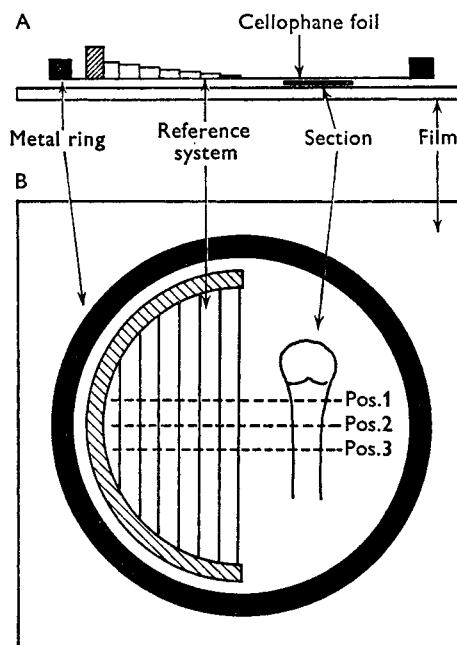

Fig. 2. Arrangement of film, section and aluminium wedge reference system in contact micro-radiography. The lines marked Pos. 1, 2 and 3 indicate the movement of the tracing beam during microdensitometry.

For quantitative evaluation of the absorption of the X-rays by the ground section, a reference system made of aluminium with known absorption was exposed on the same radiograph (aluminium is chosen because it is a convenient material and has an atomic number not far from the effective atomic number of hydroxylapatite). The system was constructed as a semicircular frame with aluminium foils arranged in steps, containing from three to nine foils (Fig. 2A). The mass of the foil was calculated to be  $0.00387 \text{ g/cm}^2$  and its thickness to be  $14.3 \text{ \mu m}$ . At exposure, the section and the reference system were arranged so that the subsequent tracing with the microdensitometer passed along the homogeneous direction of the X-ray field (hatched area in Fig. 2B). A cellophane foil was used to keep the section in close contact with the film.

*Microdensitometry*

The X-ray absorption of the section was compared with that of the reference system in a Joyce Double-Beam Automatic Recording Microdensitometer Mark III. An objective with a magnification of 20 and a slit size of  $400 \times 600 \mu\text{m}$  was used, which gives a measured area of  $(400 \times 600)/(20 \times 20) \mu\text{m}^2$ , or  $600 \mu\text{m}^2$ . The microdensitometer recorded a continuous tracing of the X-ray absorption along a line parallel with

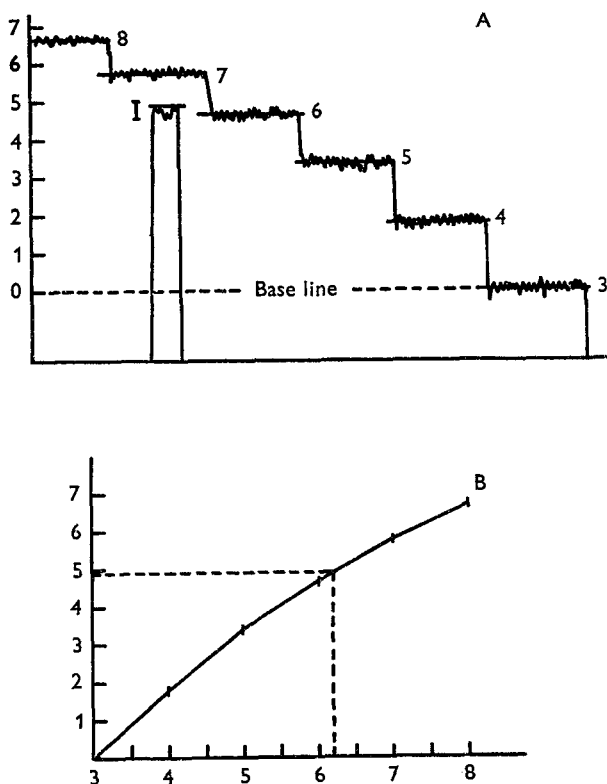

Fig. 3. (A) The microdensitometric tracing of light absorption in the microradiograph. The reference system is shown as steps numbered 3–8, and a piece of cortical bone as a peak I. (B) Plot of the reference system and reading of the aluminium equivalent value for peak I. The ordinate gives the distance from the base line, and the abscissa the number of aluminium units (foil thicknesses).

homogeneous direction of the X-ray field, thus recording the absorption in areas of  $20 \times 30 \mu\text{m}$ . The recordings were performed in three positions, respectively 2, 5 and 8 mm from the epiphyseal plate as shown in Fig. 2B. The reference system was recorded as steps. The cortical bone gave a series of peaks (Fig. 3A); the maximum value for each series of peaks represented the absorption of homogeneous areas with no vascular channels and with a minimum number of lacunae.

Each area of the micrograph where determinations were performed was carefully inspected with a microscope. Measured areas which were not homogeneous for more than  $20 \times 30 \mu\text{m}$  were rejected. Possible reasons for rejection were that the tracing

beam had passed only trabecular bone, that the vascular channels were too crowded or that the section was defective. Most of the measured areas were homogeneous for more than  $100 \times 100 \mu\text{m}$ . Of 439 measurements made, 381 were accepted. Most of the rejected measurements were in position 1, particularly in the vitamin D-deficient group.

After recording, the thickness of the section in the recorded zone was measured as described, and the density of mineralization in the actual area, expressed as percentage by volume of hydroxylapatite ( $V_{\text{HA}}$ ) was calculated according to the equation of Ericsson (1965):

$$V_{\text{HA}} = \frac{k \cdot u \cdot v}{t \cdot s},$$

where  $k$  = ratio between the mass absorption coefficient of aluminium and hydroxylapatite at  $1.54 \text{ \AA}$  ( $0.585$  according to Ericsson, 1965),  $u$  = number of aluminium foils with the same X-ray absorption as the section,  $v$  = mass of the foil ( $\text{g}/\text{cm}^2$ ),  $t$  = thickness of the section in  $\mu\text{m}$ , and  $s$  = specific gravity of hydroxylapatite ( $3.15$  according to Ericsson, 1965).

#### *Errors of the methods*

The errors of the methods are discussed by Ericsson (1965). They may arise:

(1) At exposure of the radiograph by unevenness of the X-ray field, by direct fluorescence from the section, by an uneven emulsion on the film, or by the processing.

(2) In the measurement of the thickness of the section.

(3) From the inherent properties of the specimen, e.g. the content of organic matter, lacunae and canaliculi.

It may, however, be concluded that most of the errors are non-systematic, and affect both groups equally.

#### *Statistical treatment*

To test the significance of differences  $t$  tests were applied to weight increments and blood values for Ca and P. Values for the degree of mineralization were analysed by analysis of variance, and means were adjusted for the missing values in position 1 for three animals in the vitamin D-deficient group, and in position 3 for one animal in the vitamin D-treated group (see Table 3).

## RESULTS

Table 1 shows the weight increments during the experimental period. Deficiency of vitamin D resulted in a reduction in growth in rats of both sexes, but the effects of the deficiency were greater in the females ( $30.7\%$ ) than in the males ( $14.8\%$ ). Both differences were significant ( $P < 0.01$ ). A more detailed analysis of the growth rates showed that the differences in weights occurred during the first 4 weeks of the experiment. During the last 4 weeks the growth curves in both groups were parallel.

The results of the serum analyses are shown in Table 2. The animals in the vitamin D-deficient group had a mean serum Ca level of  $6.79 \text{ mg}/100 \text{ ml}$  which is significantly different from the normal value of  $10.09 \text{ mg}/100 \text{ ml}$  ( $P < 0.001$ ). The mean serum P

value for the vitamin D-deficient group, however, was not significantly different from normal ( $0.1 > P > 0.05$ ), neither were there significant differences between sexes in the levels of serum Ca and P.

Table 1. Mean initial and final live weights (g) and weight gains of the experimental rats

Sex	Vitamin D status	No. of animals	Live weight		
			Initial	Final	Gain*
♂	Treated	7	42.3	210.9	168.6 ± 5.32
	Deficient	8	43.5	187.1	143.6 ± 6.03
♀	Treated	4	47.5	178.0	130.5 ± 1.30
	Deficient	4	48.5	139.0	90.5 ± 2.95

\* Mean values with standard errors.

Table 2. Mean values with their standard errors (mg/100 ml) for serum Ca and P of the experimental rats (both sexes combined)

Vitamin D status	No. of animals	Ca	P
Treated	11	10.09 ± 0.10	9.51 ± 0.34
Deficient	12	6.79 ± 0.34	10.23 ± 0.17

Table 3. Mean degree of mineralization in cortical bone tissue (expressed as volume % hydroxylapatite for the vitamin D-deficient and vitamin D-treated rats)

Distance from epiphyseal plate (mm)	Vitamin D-deficient group	Vitamin D-treated group	Mean value with standard error (38 df)
2	38.4* (9 rats, 29 observations)	38.1 (11 rats, 72 observations)	38.2 ± 0.16
5	40.0 (12 rats, 77 observations)	39.7 (11 rats, 83 observations)	39.9 ± 0.16
8	41.0 (12 rats, 56 observations)	40.8 (10 rats, 60 observations)	40.9 ± 0.16
Mean	39.8 ± 0.13	39.5 ± 0.13	—

\* Adjusted for missing values associated with specific rats.

Mean values for the degree of mineralization of the cortical bone in the three positions for the two groups are shown in Table 3. The degree of mineralization increased progressively from position 1 to position 3 in both groups. The differences between positions were statistically significant ( $P < 0.001$ ). The differences between the vitamin D-treated and the vitamin D-deficient groups, however, were not statistically significant ( $P > 0.05$ ).

#### DISCUSSION

The observation that the weight increment was reduced in the vitamin D-deficient rats is in accordance with earlier observations made under similar conditions with the

same strain of rats (Haavaldsen & Nicolaysen, 1956), and will not be discussed in this connexion.

The values found for serum Ca and P were also in good accordance with earlier observations on vitamin D-deficient rats given a diet with a Ca:P atomic ratio of about 1 (Steenbock & Herting, 1955; Harrison, Harrison & Park, 1958). The purpose of the high dietary levels of Ca and P in the present investigation (1.1 and 0.8% respectively) was to enable the vitamin C-deficient rats to maintain their serum Ca and P levels as close to normal as possible, in order that any direct effect of the vitamin D on bone formation and mineralization could readily be detected. If the serum Ca  $\times$  P product (ionized Ca  $\times$  total inorganic P) is calculated for the two groups of rats (assuming that 60% of the total serum Ca is ionized (Leighton, Holland & Frame, 1964)), the product for the normal rats is approximately 58 and for the vitamin D-deficient rats approximately 42. If we accept the concept that a minimum critical value for the product is necessary to allow normal mineralization, we must further inquire if a product of 42 is sufficient. The critical minimum value is species-dependent, and appears to be about 35 for rats (Yendt, Connor & Howard, 1955). In no instance did these authors find that mineralization failed to occur at that product when rachitic rat cartilage was incubated in vitro in serum with varying Ca  $\times$  P products. However, the ability of osteoid to mineralize was not tested.

It should be noted that in the vitamin D-deficient rats only the serum Ca values were reduced, while the serum P values were normal. Some investigations suggest that the level of P plays a more important role in the process of mineralization than the level of Ca (Gabbiani & Tuchweber, 1966). It is therefore reasonable to assume that the values for Ca and P obtained in the vitamin D-deficient rats in the present investigation, did not *per se* preclude normal bone formation and mineralization.

Regardless of the vitamin D status of the animals, an increasing degree of mineralization of the cortical bone in the diaphysis was found with increasing distance from the epiphyseal plate. This may possibly be an effect of age, since Amprino & Engström (1952) reported that mineralization of the osteoid very soon reached 70% of full mineralization, but that the additional mineral influx was very slow and lasted for several months.

The difference between the degree of mineralization in the vitamin D-treated and the vitamin D-deficient rats was very small and not significant. This finding seems to contradict those of Nicolaysen & Jansen (1939). These authors measured the ash content of whole femurs from young rats, which after a pre-experimental period of 30 days on a rachitogenic diet, were divided into groups and for 15 days given a number of different treatments, two of which corresponded closely to those in the present experiment. In these two groups the atomic ratio of Ca:P in the diet was about 1, and they corresponded to the vitamin D-deficient and the vitamin D-treated groups in the present study. The mean ash content of the femur in the former group was 39.9% and in the latter 49.4%.

The divergence between the results in the present investigation and those of Nicolaysen & Jansen (1939) may be due to differences in the experimental techniques. While quantitative microradiography determines the mineral content in a relatively



well-defined volume of bone tissue, traditional chemical methods give information about the ash content of a whole bone. A second reason which has to be considered is the short experimental period (15 days) used in the earlier work. After a pre-experimental period on a rachitogenic diet, on which all the rats developed rickets, a 15-day experimental period is hardly sufficient to regenerate the whole skeleton in accordance with the new dietary regime.

In a second experiment Nicolaysen & Jansen (1939) studied the effect of vitamin D on the ash content of the bones of older rats of both sexes (about 6 months old) when the general growth was low, to see if the lower degree of mineralization observed in the younger rats could be compensated for later in life. After a pre-experimental period of 135 days in which all the rats were fed on a diet deficient in vitamin D, but adequate in Ca and P, the animals were divided into groups and given a number of different dietary and injection treatments, two of which were similar to those in the present investigation. The results showed that vitamin D deficiency did not have any influence on the ash content of the femur if Ca and P were given in adequate amounts in the diet (61.3% in the vitamin D-deficient, 61.2% in the vitamin D-treated group). However, also in this investigation the experimental period was too short to allow the skeletons of the adult rats, with their low rate of growth and remodelling, to come into equilibrium with the new experimental conditions.

Using chemical methods, Harrison *et al.* (1958) investigated the degree of mineralization of the tibia of young rats given a vitamin D-deficient, but otherwise adequate diet. They found a reduction of 6.7% in the mineral content (calculated as mg Ca/g tibia). Histological investigations showed the presence of some osteoid, however, which may explain the reduction in bone mineral in relation to the total weight of the tibia.

Although the present investigation showed that vitamin D deficiency *per se* did not influence the degree of mineralization of the cortical bone tissue, it was observed that the architecture of the bone was influenced to a certain extent. This resulted in a somewhat more developed and less regular network of bone trabeculae in the metaphyseal area in the vitamin D-deficient rats and explains why most of the rejected measurements were in position 1 in that group (p. 34).

No previous determinations of the degree of mineralization using quantitative microradiography appear to have been carried out under similar conditions. It is reasonable to believe that this method may give a better estimate of the degree of mineralization of bone tissue than the traditional chemical methods in which whole bones are used. It may therefore be concluded that vitamin D deficiency in rats does not prevent the formation of a bone matrix capable of attaining a normal degree of mineralization.

The author wishes to express his gratitude to Dr Ragnar Nicolaysen for providing animals and laboratory facilities during this work, to Dr Birger Nygaard-Östby for use of the microradiographic apparatus and the microdensitometer, and to Mr Dan Wöien for advice on statistical treatment.

## REFERENCES

- Amprino, R. & Engström, A. (1952). *Acta anat.* **15**, 1.  
Ericsson, S. G. (1965). *Acta radiol.* Suppl. 246.  
Fiske, C. & Subbarow, Y. (1925). *J. biol. Chem.* **66**, 375.  
Frost, H. M. (1958). *Stain Technol.* **33**, 273.  
Gabbiani, G. & Tuchweber, B. (1966). *Acta endocr., Copenh.* **49**, 603.  
Gran, F. C. (1960a). *Acta physiol. scand.* **48**, Suppl. 167.  
Gran, F. C. (1960b). *Acta physiol. scand.* **49**, 192.  
Haavaldsen, R. & Nicolaysen, R. (1956). *Acta physiol. scand.* **36**, 102.  
Harrison, H. C., Harrison, H. E. & Park, E. A. (1958). *Am. J. Physiol.* **192**, 432.  
Leighton, G. A., Holland, R. & Frame, B. (1964). *Henry Ford Hosp. med. Bull.* **17**, 37.  
Nicolaysen, R. & Jansen, J. (1939). *Acta paediat., Stockh.* **23**, 405.  
Steenbock, H. & Herting, D. C. (1955). *J. Nutr.* **57**, 449.  
Strandh, J. (1960). *Expl Cell Res.* **19**, 515.  
Toverud, S. U. (1964). *Acta physiol. scand.* **62**, 391.  
Yendt, E. R., Connor, T. B. & Howard, J. E. (1955). *Bull. Johns Hopkins Hosp.* **96**, 101.