

# Model-Based Definition Accelerates Product Life Cycle in Manufacturing and Inspection Phase - Experiment of Machined One-Off Production

P. Uski<sup>1</sup>, A. Ellman<sup>2,✉</sup>, I. Laine<sup>2</sup>, L. Hillman<sup>3</sup> and J. Nieminen<sup>3</sup>

<sup>1</sup> Etteplan Finland Ltd, Finland, <sup>2</sup> Tampere University, Finland,

<sup>3</sup> Tampere University of Applied Sciences, Finland

✉ asko.ellman@tuni.fi

## Abstract

The paper focuses on comparative experiment on manufacturing and inspection of two different prismatic one-off parts, which have different complexity. Our experiment shows that transforming product definition method from the Drawing Centric Definition (DCD) to the Model Centric Definition (MCD) enables 28%-29% time savings in manufacturing and inspection phases of machined one-off part's life cycle. Furthermore, transition from MCD to Model-Based Definition (MBD) enables 5%-9% time savings, respectively. Applying of MBD enables more time savings in complex part compared to a less complex part.

*Keywords: model-based engineering (MBE), computer-aided design (CAD), 3D modelling*

## 1. Introduction

Product design transfers a design intent concerning a product from engineer's mind to product definition. This process has faced several development stages in last four decades due to rapid development in computer and data transfer technology. First, the product design was implemented by writing and drawing the design with ink to vellum and this phase lasted until 80ths. The second phase was shifting from physical drawing to 2D CAD design with a computer. The third phase was shifting from 2D to 3D design with a CAD software (Chandrasegaran et al., 2013). The latest step in this development is Model-Based Definition (MBD) which is based on the introduction of product and manufacturing information (PMI) into 3D CAD models making the need of engineering 2D drawings or supplementary documents unnecessary.

The product definition contains at least geometry, dimensions, tolerances, and surface quality. In addition, product definition consists of several non-dimensional pieces of information, such as title block and notes as well as additional tolerances. (Briggs et al., 2010). Engineering and manufacturing companies have utilized 3D models for several decades, especially in CAM programming, but manufacturing information such as tolerances, materials and surface quality information have been presented only in 2D drawings, Figure 1. The MBD allows the creation of an annotated 3D product definition based on a 3D solid model. This is achieved by adding product and manufacturing information directly to the 3D model, Figure 2. Such MBD dataset includes all manufacturing requirements including Geometric Dimensioning & Tolerancing (GD&T) and other required information. The MBD dataset defines complete requirements for a part in its nominal condition as well as permissible limits of variation and other acceptance criteria, providing all the data needed to plan, fabricate, and validate an article of product hardware.

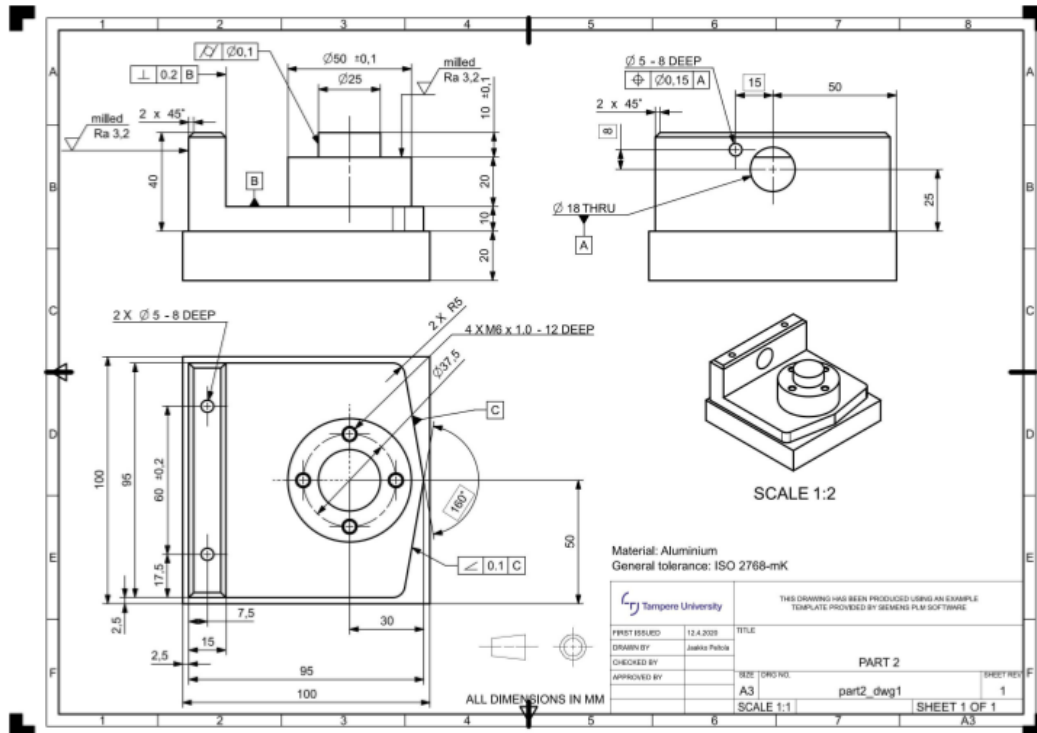

Figure 1. 2D drawing of an example part

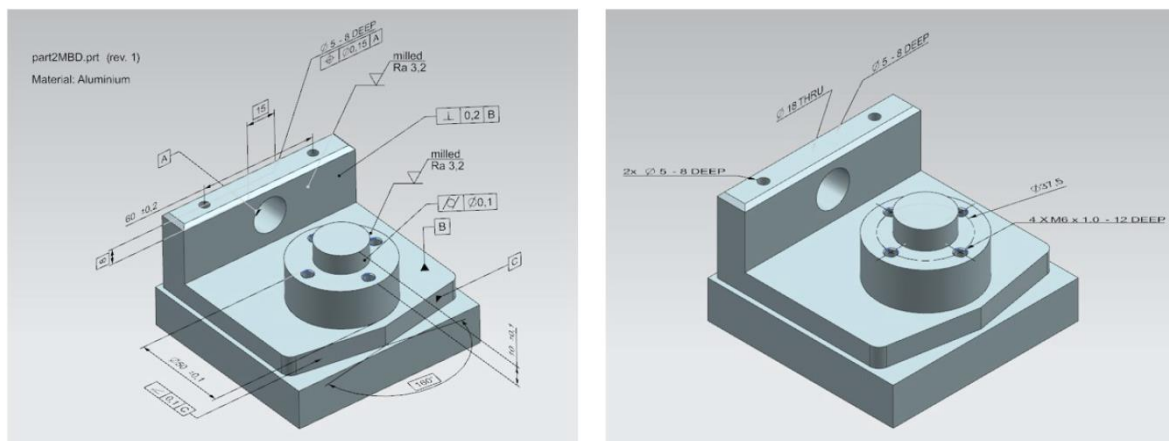

Figure 2. 3D model of an example part with PMI-information

PMI annotations (Figure 2) can be added to the 3D model as graphical presentations or as semantic PMI representation (Bijens and Chesihre, 2019). There is a significant difference between these two options. The graphical presentation is only human readable whereas the semantic PMI is also machine-readable information. Machine readability makes it possible to re-use the CAD-model in manufacturing and inspection phase of the product's life cycle. Several CAM-postprocessors can read semantic PMI information which enables more automation in CAM-code generation for manufacturing phase. Furthermore, modern coordinate measurement machines (CMM) can fully automate CAI-code generation in inspection phase which can fasten the inspection phase significantly. Emmer et al. (2018) has researched interoperability between different systems using 3D measurement data (Emmer et al., 2018).

MBD has been topic of interest for both academic and industrial actors more than two decades. Goher et al. (2020) have done a comprehensive literature study on peer reviewed journal articles on MBD that indicate a linear growth of published papers starting from 2010. In the beginning Quintana et al. (2010) studied technical requirement of MBD in Canadian aerospace. Ruemler et al. (2017) contributed on understanding the way MBD were used in various workflows in the industry. Alemanni et al. (2011) have studied implementation of MBD in aerospace and defense domains with quality function approach. Generally,

automotive and aerospace companies have been the leading industries in introducing this new technology. However, several issues on implementation of MBD have been recognized, such as: High investment costs, technological limitations, interoperability, authenticity, trustworthiness, and transformational issues (Quintana et al., 2010; Ruemler et al., 2017; Uski et al., 2020).

Bijnens and Chesihre (2019) give a critical and practical analysis on implementation of MBD. Hedberg et al. (2016) define a digital thread, as a combination of MBD, manufacturing, and inspection.

An individual enterprise is seldom responsible of both design and manufacturing of all the parts. Usually there is a network of industry players who work together to market, design, and manufacture different products. This entity is called as manufacturing ecosystem and there is a need for exchanging product and manufacturing information between engineering and manufacturing organizations. This need is one of the known issues for implementation of semantic PMI (Quintana et al., 2010, Ruemler et al., 2017, Uski et al., 2020). Especially in conventional manufacturing ecosystems all required changes for implementation of MBD have been found time consuming and challenging to companies especially due to required investments on hardware and software as well as on staff training for new work practices (Uski et al., 2020). Therefore, the latest phase in this development is still rarely adopted in most companies.

### 1.1. Manufacturing ecosystem and machined one-off production

A manufacturing ecosystem is one kind of business ecosystem (Paulus-Rohmer et al., 2016; ISO 44001, 2017). The manufacturing ecosystems were researched in the joint development and research project called “Intelligent Manufacturing Ecosystem” (IME) during 2019-2020 (Uski et al., 2020). The manufacturing ecosystem in the project consisted of one keystone company, four suppliers and an inspection laboratory. The keystone company acts as a customer for all other members in the ecosystem. A case study was executed during the IME project, and the target of the keystone company was to find out, if the MBD can benefit a machinery business.

A machined one-off part production was chosen as a study object because this topic has been especially interesting to manufacturing industry. Such a production offers most advances for MBD. A machined part usually includes dimensional and geometrical tolerances and therefore it needs to be inspected. Furthermore, the CAM- and CAI-code programming is known to be time consuming parts of the process. In serial part production this work input is not so significant as it is divided to several parts.

The research question of this paper is:

- How much time can be saved in implementation of different level of MBD at manufacturing and inspection phase of one-off production of a machined part?

The research question was studied experimentally by manufacturing and inspecting two different machined parts. The studied parts were different on complexity of design.

### 1.2. Levels of Model-Based Definition

Bijnens and Chesihre (2019) defines Model-Based Definition into four levels depending on how the keystone company and the manufacturing company are transferring the manufacturing information:

1. 2D drawings only.
2. Primary 2D drawings with supplemental 3D model.
3. Primary 3D model with supplemental 2D drawings.
4. 3D model without 2D drawings.

The Level 1 suits for companies that lack ability to utilize 3D models. These companies are usually sheet metal manufacturing suppliers as well as assembling companies that focus is not on engineering. A 2D drawing as an information transferring vehicle is usually a digital file (e.g, PDF, DXF, DWG) which is printed. The Level 2 is useful for companies that can open 3D files for review or simulation, but which do not utilize 3D models for manufacturing. The 2D drawing is mandatory document and all details must be checked in that instead of 3D model. The transferring 3D file format is often STEP AP 203/214 and 2D drawings usually stored as DWG, DXF or PDF file that will be printed for manufacturing. In the Level 3, the 3D model is a mandatory document for details and 2D drawings are included as assisting information for manufacturing. Transferring file formats are similar than in Level 2. The Level 4 is fully Model-Based Definition because 2D drawings are forbidden or they are for additional information only.

The 3D model including PMI information is often native CAD or STEP AP 242 file format and suppliers have access to the customer PLM. Three-dimensional geometry including PMI information can also be presented in a 3DPDF format. A human can read this file format (Pfouga et al., 2018).

## 2. Manufacturing and Inspection experiment

The purpose of the practical experiment was to investigate possibility to save time on the manufacturing and inspection phase of a machined part using different levels of product definition. Levels 1, 3, and 4 was used in study as they are most potential for the manufacturing ecosystem. The following acronyms are used for these product definition methods:

- DCD, Drawing Centric Definition, Level 1
- MCD, Model Centric Definition, Level 3
- MBD, Model-Based Definition, Level 4

Required time for manufacturing and inspection of two different test parts was studied in the case of three different levels of product definition data (DCD, MCD, and MBD). The main difference between the test part 1 and 2 was the complexity of the part geometry. This test represents typical one-off production where CAM- and CAI programming cover relatively large share of whole manufacturing process. In case of large serial production, programming phases represent minor share of life cycle.

### 2.1. Test parts

Test parts were defined together with a manufacturing company that is keen on developing their manufacturing processes. Complexity and prismatic form were key drivers to design the aluminium test parts. The parts are illustrated in Figure 3. The Part 1 was designed to be simpler on geometry including less machined features than the Part 2. Manufacturing the Part 2 required multi axis machining since it had bores from several directions. Furthermore, the Part 2 included also threaded holes. Both parts had geometrical shapes so that it was possible to determine dimensional and geometrical tolerances, which were inspected during the inspection phase, for them. Number of tolerances to be inspected was almost same for both parts. Table 1 includes the numbers of tolerances and machined features of the test parts. Part 1 had three pieces of geometrical tolerances and three pieces of dimensional tolerances. Two of the dimensional tolerances were tolerated using asymmetric tolerances according to ISO code system. Part 2 had three pieces of dimensional tolerances and four pieces of geometrical tolerances. All tolerances in the Part 2 were symmetric.

**Table 1. Numbers of features and tolerances in test parts**

Items	Part 1	Part 2
Machined features	4	19
Dimensional tolerances	3	3
Geometrical tolerances	3	4

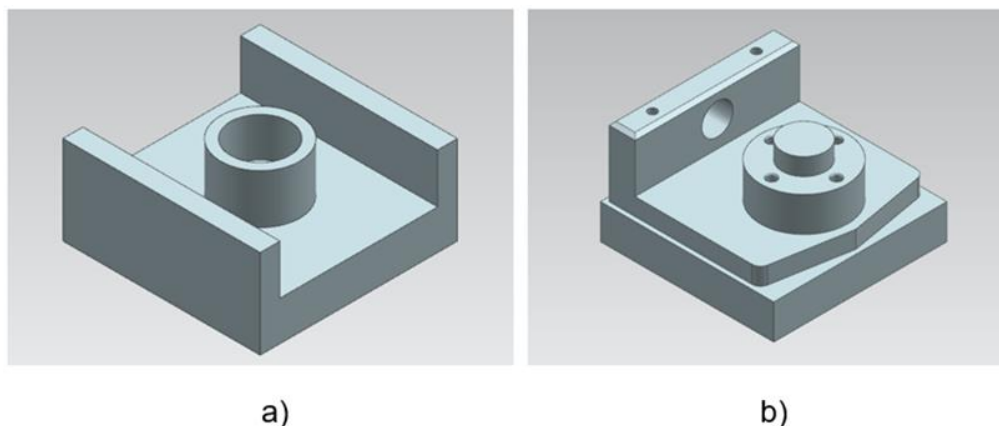

**Figure 3. Part 1 (a) and Part 2 (b)**

## 2.2. Test procedure

The manufacturing and inspection test was performed in following order:

5. First, by using 2D drawings only (DCD).
6. Second, with 3D CAD model and 2D drawings as supporting material (MCD).
7. Third, with 3D PMI-annotated model only (MBD).

CAM programming with 3D model was performed by a professional CAD/CAM teacher. CAM programming with 2D drawings and other tasks in manufacturing were completed by professional machinist from university's manufacturing laboratory. The inspection was performed in measurement laboratory of the university by two professional CAD/CAM lecturers. All these four persons are professionals in their field with more than 10-year work experience. The experiment was completed with Siemens NX CAD software version 12.0.1.7. The machining center was Mikron MILL P 800 U with five axes. The coordinate measurement machine was Mitutoyo Crysta Apex 574S and the assisting software was Mitutoyo MiCat Planner 1.7 and Mitutoyo Mcosmos 4.3.

## 3. Test results

Manufacturing in one-off part production is consisting of seven phases:

8. CAM-programming
9. Simulation of tool paths in machining center
10. Manufacturing the blank
11. Fastening the blank to machining center
12. Preparing tools in machining center
13. Machining
14. Finishing the part

The manufacturing phase starts with CAM programming. After creating the CAM program, it was converted to NC code to be delivered for machining center. In case of 3D CAD model, the CAM programming was performed in CAD software using its CAM extension with model of machine center. The essential aspect on this is that CAM programming is performed off-line from machining center and its time is not needed for CAM programming.

The second phase of the manufacturing is simulation of tool paths in the control system of the machining center using the NC code. This phase is important to make sure that the generated NC code is valid and will not cause expensive and dangerous machine damages due to collision of tools with the blank or fixture. The simulation time was 5 min in each case.

In one-off part production there are not existing blanks ready to be fed to machining center. Therefore, they need to be manufactured first from a base material profile. In this case the manufacturing of blanks included sawing aluminum blocks from appropriate base material profile with band saw. Manufacturing time for blanks was 10 min in each case. The manufactured blanks need to be fastened to the machining center. The used fixture was a clamp with a base that is aligned with the machine coordinate system. Therefore, there was no need to determine the position of the blank in the coordinate system of machining center. Time for fastening blanks was 15 min in each case.

Before machining, all needed machining tools need to be installed to the machine center tool magazine for automatic tool changes. The needed tools must first be fastened to tool holders that are suitable for tool magazine. After fastening the tool to its holder, it must be measured to ensure accurate machining. The actual dimensions of each tool are measured and the dimensions in tool library are corrected according to the measurements. For example, the wearing of tools can be considered as the tools are measured. This preparation phase took 150 min in each case. After the preparations, machining was performed for each test part by executing the created machining programs.

After executing the machining programs the parts were finished. Finishing included finishing the unmachined base of the blank and removing sharp edges. The base of the blank was finished by turning the part in fixture and milling the base of the blank clean. The sharp edges were removed manually with suitable grinder tool. The finishing took 20 min in each case.

**Table 2. Time consumption for different tasks during manufacturing of Part 1 using DCD, MCD and MBD approach**

Part 1	DCD	MCD	MBD
Task	[min]	[min]	[min]
CAM programming	130	30	30
Simulation on machining centre	5	5	5
Manufacturing blank	10	10	10
Fastening blank	15	15	15
Preparing tools	150	150	150
Machining	13	13	13
Finishing	20	20	20
TOTAL	343	243	243

**Table 3. Time consumption for different tasks during manufacturing of Part 2 using DCD, MCD and MBD approach**

Part 2	DCD	MCD	MBD
Task	[min]	[min]	[min]
CAM programming	152	60	57
Simulation on machining centre	5	5	5
Manufacturing blank	10	10	10
Fastening blank	15	15	15
Preparing tools	150	150	150
Machining	14	14	14
Finishing	20	20	20
TOTAL	366	273	270

In case of DCD the 2D drawing is first converted to 3D model and CAM programming is then performed based on this model and 2D drawing. Clearly missing of the 3D model cause unnecessary work in this option. In case of MCD the 3D model was opened in NX manufacturing postprocessor tool that will create the CAM code by human control. The NX manufacturing postprocessor tool enables simulation of machining activity. However, this simulation was repeated also in the machining centre to be on safe side. In MBD case the CAM programming was basically performed in similar way as in MCD case. However, PMI-information was exploited in copying similar machining features such as threaded holes in Part 2. Therefore, the CAM programming was slightly faster in MBD case compared to MCD case. It is noticeable that difference would be more significant if there would have been more similar machining features in Part 2. MBD enables also automated CAM-code production. However, this would have required a complete library of machined features covering all possible machined features and materials. This option was unrealistic to be used in one-off production.

### 3.1. Inspection

After manufacturing, all the geometrical tolerances and dimensional tolerances of the test parts were inspected in coordinate measuring machine (CMM). The inspection is consisting of three phases:

15. Fastening the part
16. CAI programming
17. Measuring

Inspection started with fastening the inspected part to CMM. The part was fastened using a clamp and it was made sure that the measuring probe of the CMM was able to reach all the measured features. Fastening the part took 15 min in each case.

After CAI programming the created program was executed to generate measuring reports which indicate the validity of machined parts according to the inspected tolerances. Once the measuring program is created it can be used to inspect parts automatically without reprogramming. The times used for inspection phase are presented in Table 4 and 5 for Part 1 and 2.

**Table 4. Time consumption for different tasks during inspection of Part 1 using DCD, MCD, and MBD approach**

Part 1	Time [min:s]	Time [min:s]	Time [min:s]
Task	DCD	MCD	MBD
Fastening the part	15:00	15:00	15:00
CAI programming	30:00	15:00	0:01
Measuring	3:06	2:48	3:28
TOTAL	48:06	32:48	18:28

**Table 5. Time consumption for different tasks during inspection of Part 2 using DCD, MCD, and MBD approach**

Part 2	Time [min:s]	Time [min:s]	Time [min:s]
Task	DCD	MCD	MBD
Fastening the part	15:00	15:00	15:00
CAI programming	60:00	28:00	0:02
Measuring	4:24	4:16	5:47
TOTAL	79:24	47:16	20:49

The higher complexity of Part 2 can be seen as higher execution times for both in CAI programming and for measuring. Because the CMM software can read PMI-information in MBD-case, the CAI-programming will take place automatically and its execution time is only 1-2 s. However, this automatically created CAI-code is less efficient as human made code in MCD-case. In Part 1 the difference is 40 s and in Part 2 it is already 91 s. In the case of one-off product manufacturing this difference is not meaningful, but in case of small series manufacturing, this difference might become important.

**Table 6. Comparison of time savings achieved by transforming from DCD to MCD**

	Task	DCD [min]	MCD [min]	$\Delta$ [min]	$\Delta$ [%]
Part 1	Manufacturing	343	243	100	29.2
	Inspection	48.1	32.8	15.3	31.8
	TOTAL	391.1	275.8	115.3	29.5
Part 2	Manufacturing	366	273	93	25.4
	Inspection	79.4	47.3	32.1	40.4
	TOTAL	445.4	320.3	125.1	28.1

Table 6 compares time savings in manufacturing and inspection phase as well as total time saving for Part 1 and 2 that were achieved by transforming from DCD based method to MCD. This transformation enables significant time savings. In case of Part 1 this is 29.5% and in case of Part 2 this is 28.1%. This due to fact that in DCD method it is necessary to re-create part's 3D model from 2D drawings for both manufacturing and inspection phase. This is in practise more efficient method than generating CAM- and CAI code according to 2D drawings. Furthermore, this extra phase is sensitive to human errors in re-modelling of a part. In MCD method the machinist or inspector have the 3D model of the part and he/she can directly study and measure features in 3D model, which reduces probability of human error in CAM and CAI coding. Time savings are achieved both in

manufacturing and inspection phase. However, due to its magnitude, savings in manufacturing phase dominates the entity.

**Table 7. Comparison of time savings achieved by transforming from MCD to MBD**

	Task	MCD [min]	MBD [min]	$\Delta$ [min]	$\Delta$ [%]
Part 1	Manufacturing	243	243	0	0
	Inspection	32.8	18.5	14.3	43.6
	TOTAL	275.8	261.5	14.3	5.2
Part 2	Manufacturing	273	270	3	1.1
	Inspection	47.3	20.8	26.5	56.0
	TOTAL	320.3	290.8	29.5	9.2

Table 7 compares time savings in manufacturing and inspection phase as well as total time saving for Part 1 and 2 that were achieved by transforming from MCD based method to MBD. This transformation enables some time savings. In case of Part 1 this is 5.2% and in case of Part 2 this is 9.2%. This improvement is due to fact that within MBD method the CAI code can be generated automatically. However, the automatically generated CAI code is less efficient than human made code which slow down the measurement phase a bit. In case of one-off production this not an issue but in case of small series manufacturing this may become a problem. Manufacturing dominates the total time also in this case. Unfortunately, this phase could not be speed up much. MBD basically enables automatic CAM code generation, but this possibility is rarely used due to lack of generic machining feature library. The Part 2 has four similar threaded holes, and such machined features needs to define only once. This enables some time saving in CAM coding of the part 2.

## 4. Conclusions

Improving the level of product definition method enables possibilities for time savings in product's life cycle. This is especially true in one-off and in small series production where workload related to CAM and CAI coding is meaningful. Within transition from Drawing Centric Definition (DCD) to Model Centric Definition (MCD) it was possible to obtain time savings of 29.5% in the case of part 1 and 28.1% in the case of part 2. Furthermore, within transition from Model Centric Definition (MCD) to Model-Based Definition (MBD) it was possible to obtain time savings of 5.2% in the case of part 1 and 9.2% in the case of part 2. Part 1 and 2 differs from their complexity. Part 2 includes more features than Part 1.

Increasing the complexity of part geometry naturally increases both manufacturing and inspection time. Within transition from MCD to MBD this was not so clear. However, in transition from DCD to MCD this increase was more obvious. Our study gives indication that MBD method enable more time saving within increasing complexity of a part geometry. This is especially true if the part includes several similar machining features.

MBD method enables time savings in life cycle of a machined part. This prerequisite however, that semantic PMI-information is included in CAD model already in design phase.

## 5. Discussion

Our study was focused on one-off and small series production where workload related to CAM and CAI coding is meaningful. In mass production this is less important because there the CAM and CAI codes need to be optimized more carefully by human for minimizing manufacturing and inspection times.

Although our research topic was focused on time saving, the most benefit and value comes particularly from better and clear communication between stakeholders. (Quintana et al., 2010; Ruemler et al, 2017). Using 3D annotations for defining dimensions and tolerances is more pictorial and less sensitive for errors than using 2D projections on a complex part. Furthermore, machine



readability of CAD models reduces possibilities for misunderstandings both in CAM and CAI coding. Wider, 3D dataset can be used for better communication for example in assembling process where tolerances as well as geometrical shape can be presented with free viewer software using light CAD models such as JT-models.

Issues on validity of design information is limiting the re-use of design information. It was found in study by [Ellman et al. \(2018\)](#) that 58% of engineers in that study didn't trust existing design information. They explained that identified errors in blueprints are not always updated to CAD models and therefore it is most certain to start a new design from a white paper. Obviously, MBD method can offer improvement on this issue ([Camba et al, 2014](#)).

According to [Ruemler et al. \(2017\)](#), lack of business pull is one of the biggest barriers towards utilizing MBD. However, there are also opposite examples. In Randselva Norway a 634 meters long bridge will be built in 2022. The international engineering work has been done totally without drawings, basis on building information model e.g., 3D model. The 3D model is used in construction site as well. This is good example of how large constructions can be designed and built according to 3D models only. The motivation to design and build the bridge without drawings came from the customer, Norway's public road authorities that wanted to reduce costs and throughput time due to engineering changes by utilizing model-based definition, especially BIM ([Randselva Bridge, 2020](#)).

Despite of its advantages, commissioning of MBD in companies is challenging. Firstly, engineers need to learn to use semantic PMI annotations in 3D models instead of 2D projections for manufacturing information. Secondly, the engineering workshop need to invest on required software and hardware enabling utilization of semantic PMI information in their activities. Commissioning of MBD requires therefore investments on new technology, learning new skills and new methods to work. Obviously, this will take time, however, industry is nowadays keen to take this technology step.

## 6. Future studies

We had only two test parts with different complexity in our study. Obviously, advance of MBD increases with part's complexity. Thus, we would like to study this topic with several and more complex parts including design process. Furthermore, efficiency of automatic generated NC code would be interesting to compare with manual generated NC code.

## References

- The AP242 standard project. (2009). Development of a Convergent Modular STEP Application Protocol Based on AP 203 and AP 214: STEP AP 242 – Managed Model Based 3D Engineering [http://www.ap242.org/c/document\\_library/get\\_file?uuid=157a9a8f-6888-4589-906d-71d09e75878c&groupId=52520](http://www.ap242.org/c/document_library/get_file?uuid=157a9a8f-6888-4589-906d-71d09e75878c&groupId=52520)
- Alemanni M, Destefanis F and Vezzetti E (2011) Model-based definition design in the product lifecycle management scenario. *International Journal of Advanced Manufacturing Technology* 52(1–4): 1–14. DOI: 10.1007/s00170-010-2699-y.
- Bijnens J and Cheshire D. The current state of model-based definition. *Comput Aided Des Appl* 2019; 16:308–317. DOI: 10.14733/cadaps.2019.308-317
- Briggs C, Brown G, Siebenaler D, et al. (2010) Model Based Definition. In: 51st AIAA/ASME/ASCE/AHS/ASC Structures, Structural Dynamics, and Materials Conference, Orlando, 2010. ISSN 2010-3138
- Camba J, Contero M, Johnson M, et al. (2014) Extended 3D annotations as a new mechanism to explicitly communicate geometric design intent and increase CAD model reusability. *CAD Computer Aided Design* 57. Elsevier Ltd: 61–73. DOI: 10.1016/j.cad.2014.07.001.
- Chandrasegaran SK, Ramani K, Sriram RD, et al. (2013) The evolution, challenges, and future of knowledge representation in product design systems. In: *CAD Computer Aided Design, 2013*, pp. 204–228. Elsevier Ltd. DOI: 10.1016/j.cad.2012.08.006.
- Ellman A., Paronen J., Juuti T, Tiainen, T (2018) Re-Use of Engineering Design Rationale in Finnish SME Project Based Industry. *Proceedings of the DESIGN 2018 15th International Design Conference* pp 1825–1832. DOI: doi.org/10.21278/idc.2018.0363
- Emmer C., Hofmann T, et al. (2018) A neutral approach for interoperability in the field of 3D measurement data management. *Journal of Industrial Information Integration* 12(2018) pp 47-56. ELSEVIER. DOI: doi.org/10.1016/j.jii.2018.01.006

- Hedberg T, Lubell J, Fischer L, et al. Testing the digital thread in support of model-based manufacturing and inspection. *J Comput Inf Sci Eng* 2016; 16: 021001.
- ISO 44001:2017 Collaborative business relationship management systems — Requirements and framework. 2017-03, <https://www.iso.org/standard/72798.html> (accessed 29.2.2020).
- Paulus-Rohmer, D., Schatton, H., Bauernhansl, T.: Ecosystems, strategy and business models in the age of digitization - How the manufacturing industry is going to change its logic. In: Editor, F., Editor, S. (eds.) 49th CIRP CONFERENCE on Manufacturing Systems (CIRP-CMS 2016) 2016, vol. 57, pp. 8–13. Elsevier B.V., (2016).
- Peltola J (2020) Model Based Definition of Machined Part. Tampere. Available at: <http://urn.fi/URN:NBN:fi:tuni-202008246598> (accessed 8 November 2020).
- Pfouga, A, Stjepandić, J (2018) Leveraging 3D geometric knowledge in the product lifecycle based on industrial standards. *Journal of Computational Design and Engineering* 5(2018) pp 54-67. DOI: 10.1016/j.jcde.2017.11.002
- Randselva Bridge, Tekla (2020). Available at: <https://www.tekla.com/bim-awards/randselva-bridge> (accessed 7 November 2020).
- Ruemler SP, Zimmerman KE, Hartman NW, et al. (2017) Promoting model-based definition to establish a complete product definition. *Journal of Manufacturing Science and Engineering, Transactions of the ASME* 139(5). American Society of Mechanical Engineers (ASME). DOI: 10.1115/1.4034625.
- Quintana V, Rivest L, Pellerin R, et al. (2010) Will Model-based Definition replace engineering drawings throughout the product lifecycle? A global perspective from aerospace industry. *Computers in Industry* 61(5): 497–508. DOI: 10.1016/j.compind.2010.01.005.
- Uski P, Pulkkinen A, Hillman L, et al. (2020) Issues on Introducing Model-Based Definition-Case of Manufacturing Ecosystem. In: 10 November 2020. Springer, Cham. DOI: [https://doi.org/10.1007/978-3-030-62807-9\\_48](https://doi.org/10.1007/978-3-030-62807-9_48).