

# Language interference and inhibition in early and late successive bilingualism\*

ELENI PERISTERI

*School of English, Department of Theoretical and Applied Linguistics, Aristotle University of Thessaloniki*

IANTHI MARIA TSIMPLI

*Department of Theoretical and Applied Linguistics, University of Cambridge*

ANTONELLA SORACE

*School of Philosophy, Psychology & Language Sciences, University of Edinburgh*

KYRANA TSAPKINI

*Department of Neurology, Johns Hopkins Medicine*

(Received: June 22, 2016; final revision received: June 22, 2017; accepted: June 23, 2017; first published online 11 October 2017)

*The present study explores whether age of onset of exposure to the second language affects interference resolution at the grammatical gender level and whether cognitive functions contribute to interference resolution. Early and late successive Serbian–Greek bilinguals living in the second language context, along with monolinguals, performed a picture-word interference naming task in a single-language context and a non-verbal inhibition task. We found that gender interference from the first language was only present in late successive bilinguals. Early bilinguals exhibited no interference from the grammatical gender of their mother tongue and showed more enhanced inhibitory abilities than the rest of the groups in the non-verbal task. The distinct sizes of interference from the grammatical gender of the first language across the two bilingual groups is explained by early successive bilinguals' more enhanced domain-general inhibitory processes in the resolution of between-language conflict at the grammatical gender level relative to late successive bilinguals.*

Keywords: bilingualism, grammatical gender, age of onset, inhibition

## Introduction

Recent research on bilingualism has shown that lexical access in isolated visual word recognition by bilinguals is non-selective, with phonological and/or semantic information about words in each language being activated in parallel even when reading or listening to a word in one language alone (e.g., Costa, Caramazza & Sebastián-Gallés, 2000; Dijkstra, 2005; Macizo & Bajo, 2006; Marian & Spivey, 2003). Cross-language activation of the language not in use is observed even when bilinguals are highly proficient in the second language (L2) or when they maintain dominance in their first language (L1). Sebastián Gallés, Rodríguez-Fornells, Diego-Balaguer, and Diaz (2006), for example, have reported interference effects when Spanish-dominant bilinguals had to decide on the lexical status of non-word items which were phonologically similar to existing Catalan (L2) words.

Grammatical gender is a classificatory syntactic feature valued on the noun's lemma, i.e., at a level distinct from the conceptual or phonological representation of the noun

(Chomsky, 1995; Corbett, 1991; Levelt, Roelofs & Meyer, 1999). Thus, unlike other grammatical features of nouns whose values are optional in that they are determined by the syntactic context in which they occur (Chomsky, 1995), the value of grammatical gender is lexically specified. In many languages, like Spanish, French and Greek, gender is morpho-phonologically realized through the agreement of elements (e.g., determiners, adjectives, nouns) within the Determiner Phrase (DP).

The processing of grammatical gender in the monolingual mental lexicon has been well-documented in the literature, with relevant evidence coming primarily from offline picture-naming experiments and online picture-word interference (PWI) paradigms (Alario & Caramazza, 2002; Costa, Sebastián-Gallés, Miozzo & Caramazza, 1999; Janssen & Caramazza, 2003; La Heij, Mak, Sander & Willeboordse, 1998; Miozzo & Caramazza, 1999; Miozzo, Costa & Caramazza, 2002; Schiller & Caramazza, 2003; Schriefers, 1993; Schriefers, Jescheniak & Hantsch, 2002; Schriefers & Teruel, 2000). How activation of and access to grammatical gender representations takes place is subject to different accounts in the psycholinguistic literature. More modular models claim that information about a word's grammatical gender is activated before and independently of the

\* We would like to thank our participants for their unfailing interest in our study and the hours of their participation.

Address for correspondence:

Eleni Peristeri, School of English, Department of Theoretical and Applied Linguistics, Aristotle University of Thessaloniki, 54124, Thessaloniki, Greece

[eperiste@enl.auth.gr](mailto:eperiste@enl.auth.gr)

word's conceptual or/and phonological form (Marx, 1999; Van Turenout, Hagoort & Brown, 1998). On the other hand, constraint-satisfaction models consider the availability of gender information as an automatic consequence of the selection of one lexical–phonological node (Caramazza & Miozzo, 1997) or, alternatively, that gender retrieval results from a competitive process among relative activation levels of the target and distractor words (Cubelli, Lotto, Paolieri, Girelli & Job, 2005; Levelt et al., 1999; Paolieri, Cubelli, Macizo, Bajo, Lotto & Job, 2010; Schriefers, 1993).

One particular aspect of gender retrieval for which competition-based models make contradicting assumptions is the context in which the gender of a distractor word may interfere. It has been assumed that grammatical gender is selected only in the production of noun phrases (Alario & Caramazza, 2002; Caramazza & Miozzo, 1997; La Heij et al., 1998; Levelt et al., 1999; Schriefers, 1993; Schriefers & Teruel, 2000) or in bare noun production also (Cubelli et al., 2005; Ganushchak, Verdonschot & Schiller, 2011; Paolieri et al., 2010). According to the former hypothesis, grammatical gender is only accessed when specifically required within a sentential context for the selection of gender-marked determiners and/or agreement morphemes (SYNTACTIC HYPOTHESIS); if this hypothesis is true, gender effects are not expected to emerge when a noun is produced in isolation. According to the second theory, grammatical gender is an intrinsic part of the noun's lexical representation and it is always available when a lexical item is retrieved (LEXICAL HYPOTHESIS; Cacciari & Cubelli, 2003; Carstens, 2000; Mastropavlou & Tsimpli, 2011). What follows from the lexical hypothesis is that gender effects should emerge in all tasks requiring lexical access.

Theories concerning how grammatical gender interacts during lexical selection in bilingual speakers have not been less contradicting than the theories on the processing of grammatical gender in native speakers. For instance, the gender-shared hypothesis states that gender specifications, and hence inherent syntactic properties of words, are shared across languages; if L1 and L2 gender features are shared, then the activated L1 gender information will affect the retrieval and selection of the L2 gender; it will facilitate retrieval if it coincides with L2 gender or inhibit retrieval if it is different from the L2 gender (La Heij et al., 1998; Levelt et al., 1999; Roelofs, 1998). On the other hand, the gender independent hypothesis claims that gender features are language-specific: as such there should be no gender-congruency effects across languages (Costa et al., 2003; Foucart, 2008). If L1 and L2 gender features are independently represented, L1 gender information may be activated but will not influence gender retrieval and selection in L2, even when the target utterance requires computation of gender information.

Evidence in favor of the complete autonomy or interdependence of the gender systems of the two languages of bilinguals has been provided by several studies with language production experiments that have mainly examined how cross-language activation at the gender level modulates word retrieval capacities in real time. Costa, Kovacik, Franck, and Caramazza's (2003) and Foucart's (2008) picture-naming studies both explored cross-language transfer of gender properties in highly proficient bilinguals. Both studies found no difference in naming latencies for the gender congruent and incongruent conditions, nor a significant congruency effect depending on whether the two languages shared the same or different grammatical gender across lexical items. The absence of significant interactions between the two languages suggested to the authors that the gender systems in highly proficient bilinguals may be represented separately for each language, making it, thus, possible for bilingual speakers to restrict lexical access to the language selected for speaking, or, alternatively, that proficient bilinguals may not rely on inhibitory control of the language not in use but rather on enhanced activation of the language in use (Costa & Santesteban, 2004, 2006).

Other studies, however, obtained different results from Costa et al. (2003). More specifically, transfer of grammatical gender properties of a first to a second language has been found in a number of bilingual populations irrespective of whether both languages had their gender grammaticalized (Bordag & Pechmann, 2007; Lemhöfer, Spalek & Schriefers, 2008; Morales, Paolieri & Bajo, 2011; Paolieri et al., 2010; Salamoura & Williams, 2007) or not (Ganushchak et al., 2011). What should be noted is that in these studies all bilinguals were highly proficient individuals; therefore, it is not fully understood to what extent cross-language interaction at the grammatical gender level is conditioned by language proficiency or age of L2 acquisition. Furthermore, inhibitory control in grammatical gender interference has been studied separately from cognitive control despite the fact that early exposure to the L2 and relative balance in the dominance of the two languages have been shown to result in more enhanced language control abilities in bilinguals (e.g., Bialystok, Craik & Luk, 2012; Fiszler, 2008; Luk, DeSa & Bialystok, 2011). Green's Inhibitory model (1988) was one of the first to suggest that different languages are represented by different language schemes and use of one language involves inhibitory control over the interfering non-target language. However, the studies that have investigated the interaction of gender systems in bilingual language production rarely discussed the role and the function of the bilingual speakers' inhibitory control in the PWI tasks.

As such, the question whether the lack or presence of gender congruency effects in bilingual populations may also relate to distinct cognitive control abilities

stemming from variation in their inhibitory functions has not been yet explored. The present study is concerned with timing differences that early and late successive bilinguals display in picture naming when the nouns of the two languages have the same or different grammatical gender, and how the bilinguals' performance may be linked to the participants' age of onset of exposure to the L2, as well as to differences in the participants' non-verbal inhibition abilities.

### The present study

In our study we investigated cross-language gender activation effects and non-verbal inhibition in two groups of early and late successive Serbian–Greek bilingual speakers and a group of Greek-speaking monolinguals. The three groups were tested on the same experiments.

The first task was a PWI naming task, in which participants are asked to name pictures as quickly as they can while ignoring a distractor word that is superimposed on the target picture. The relationship between the distractor word and the picture has been shown to affect participants' response times in picture naming. A well-established finding is that participants take longer to name a target picture when a distractor word is present (*vs.* no distractor word) and longer yet when the to-be-ignored distractor word is categorically related to the picture (e.g., Caramazza & Costa, 2000; De Zubicaray, Miozzo, Johnson, Schiller & McMahon, 2012; Glaser & Glaser, 1989; Lupker, 1979). This finding has been interpreted in terms of competitive lexical selection processes (Levelt et al., 1999; Roelofs, 1998; Starreveld & La Heij, 1996); for instance, in cases of semantic PWI tasks a distractor word that is semantically related to the picture will be more highly activated than an unrelated word, and it will consequently compete more fiercely for selection because of its increased activation.

The present study used a PWI paradigm that invoked competition at the grammatical gender level. Specifically, the task manipulated grammatical gender (in)congruencies within the same/target language, i.e., Greek, and interlingual gender competition, i.e., between Greek and Serbian, with half of the items sharing the same grammatical gender across the two languages and the rest having different gender features. In this task, participants were asked to name target pictures in Greek by producing DP sequences and ignore the distractor word. In line with the lexical hypothesis (Cacciari & Cubelli, 2003; Carstens, 2000; Mastropavlou & Tsimpli, 2011), which claims that gender is activated in all tasks requiring lexical access, we assume that the gender feature of both the pictured noun and the distractor word would be activated, thus, resulting in gender congruency effects. The gender value of the DP in Greek is determined by the gender value of the head noun and is spread to all its modifying elements, including

the determiner, through agreement. In this sense, we hypothesize that heightened activation of a non-target gender node stemming from either the distractor word or the pictured noun's translational equivalent in Serbian would result in gender congruency effects reflected in delayed DP naming. What should be stressed is that the specific language experiment did not test knowledge of grammatical gender but rather measured grammatical gender production for Greek nouns whose gender was known by all participants as confirmed by a picture naming screening test administered before the PWI task (see Methodology).

The second was a non-verbal spatial target-stimulus locating task modelled after Treccani, Argyri, Sorace, and Della Sala (2009). The specific task has been used to index balanced bilinguals' and monolinguals' ability to inhibit perceptual conflict in non-linguistic input. In this task, participants were asked to detect target stimuli ('X') which were presented along with to-be-ignored distractors ('O'). The PWI and the non-verbal target detection task allowed us to investigate language and cognitive control processes as well as possible interactions between the two processes in each bilingual group.

Considering evidence of previous studies on bilingual speech production showing that gender is activated in the non-response language and that subsequent cross-language competition is resolved by the recruitment of domain-general inhibitory processes (LANGUAGE NON-SELECTIVITY MODEL; Lemhöfer et al., 2008; Morales et al., 2011; Paolieri et al., 2010), we hypothesize that both early and late successive bilingual groups will experience L1 interference at the grammatical gender level during picture naming in the L2. Moreover, given early successive bilinguals need to concentrate on the relevant linguistic system and suppress interference from the second linguistic system in language production over a more extended period of time than late successive bilinguals (e.g., Bialystok et al., 2012; Luk et al., 2011), we hypothesize that early successive bilinguals should experience a smaller size of between-language interference caused by the grammatical gender system of the language not in use (i.e., Serbian) compared to the late successive bilingual group. If early successive bilinguals enjoy more enhanced inhibitory capacities than late successive bilinguals (Bialystok, 2010, 2011; Bialystok, Craik, Klein & Viswanathan, 2004; Tao, Marzecová, Taft, Asanowicz & Wodniecka, 2011), we expect early successive bilinguals to show different response patterns from late successive bilinguals, and convergence on the monolingual native group's profile in the PWI task.

With respect to the within-language congruency effects in the PWI task, we expect that monolinguals will show a robust congruency effect, which is in line with previous studies examining gender congruency effects in monolingual populations (e.g., Costa et al.,

2003; Schiller & Caramazza, 2003; Schriefers, 1993). We also expect a discrepancy to emerge between early and late successive bilinguals reflected in the emergence of an L2 congruency effect in early successive bilinguals only, due to the specific group's greater reliance on procedurally-based grammatical gender knowledge in Greek. Following Ullman's (2001) dual-process account of lexical processing, we hypothesize that early successive bilinguals' naming responses will be subject to consolidated, highly intuitive grammatical gender constraints in the L2 that have precedence over working memory and cognitive ability. Crucially, proceduralization of relevant grammatical knowledge in Greek is predicted to result in an automation of processing gender congruency relations in Greek and native-like performance in the PWI task. On the other hand, we expect late successive bilinguals' naming performance to rely on a rather analytical-logical deliberation enforced by rule-following rather than intuitive knowledge during gender assignment; such deliberation in lexical processing is expected to prevent the emergence of a congruency effect in the L2 for the late successive bilingual group.

Finally, in line with a number of studies (e.g., Luk et al., 2011; Tao et al., 2011) showing that early successive bilinguals exhibit more efficient inhibitory control abilities than late successive bilinguals because early successive bilinguals use their inhibitory control abilities from early on in their life, we expected that the early successive bilingual group would show an advantage over late successive bilinguals on the non-verbal task involving interference suppression. Thus, early successive bilinguals should have faster RTs and/or higher accuracy of target-detection than late successive bilinguals in the non-verbal spatial target-stimulus locating task.

### The grammatical gender systems in Serbian and Greek

Serbian nouns are coded for grammatical gender (masculine, feminine, neuter), number and case within a single suffix (e.g., медвед (medved) 'bear', крава (kravu) 'cow', село (selo) 'village'). Masculine nouns usually end in a consonant, while feminine nouns end in /-a/ and neuter nouns in /-o/ and /-e/, although not without exceptions (Seva, Kempe, Brooks, Mironova, Pershukova & Fedorova, 2007). Serbian nouns agree with quantifiers, possessives, and ordinary adjectives in gender, number (singular, plural) and case (7 cases), in a single (syncretic) suffix (e.g., ovaj student "this-N.Masc.Sing. student-N.Masc.Sing.", stara knjiga "old-N.Fem.Sing. book-N.Fem.Sing.", svaka ova knjiga "each-N.Fem.Sing. this-N.Fem.Sing. book-N.Fem.Sing."; examples taken from Zlatić, 1997). Subject nouns agree with the verb in number as well as gender in some cases. In many of these properties Serbian is similar to other grammatical

gender languages. According to Corbett (1988, 1991), the Serbian gender system is morphological since the gender value of a noun can be reliably identified if inflectional forms of the noun other than the citation form (nominative singular) are taken into account.

Greek is also a grammatical gender language with a tripartite gender distinction: masculine-feminine-neuter. This distinction is marked on definite determiners in both the singular and the plural, on indefinite articles, as well as adjectives. Gender marking on the noun follows certain phonological regularities (e.g., in the citation form an -s ending usually marks masculine, whereas /-a/ and /-o/ mark feminine and neuter, respectively). More specifically, Greek nouns are suffixed by a syncretic form, which includes gender, number, and case information (Holton, Mackridge & Philippaki-Warbuton, 2004; Ralli, 2002). With respect to gender marking, Mastropavlou and Tsimpli (2011) show that despite the possibility of some of these endings such as /-os/ and /-i/ to occur with more than one gender feature (e.g., /-os/ could be masculine, feminine or neuter while /-i/ could be feminine or neuter), predictive values are very high for one of these values, ranging from .84 to .98 (cf. Varlokosta, 2011). The only exception is ending /-i/ which is indeed ambiguous between feminine and neuter gender in spoken language, since spelling conventions distinguish between the two. Crucially, although noun gender is in many cases identifiable on the noun suffix alone, use of a determiner (definite or indefinite) to introduce the noun eliminates any ambiguity on the gender value.

On the basis of the above, the main difference between Greek and Serbian refers to the lack of a definite/indefinite article system in Serbian. Accordingly, while Greek has a determiner paradigm which also agrees with the noun in terms of gender, number and case, Serbian determiners such as *jedan/neki* 'one/some' or demonstratives such as *ova* 'this' have been argued to function as adjectives according to some analyses (Bošković, 2006; Trenkic, 2004), while others have argued that the noun phrase in Serbian is a DP (Bašić, 2004; Progovac, 1998). Despite this difference, a number of factors like the similarities in gender-marking cues on the noun itself, the three-way gender distinction shared by both languages, the spread of gender agreement marking on all elements in the noun phrase and the availability of semantic and morpho-phonological cues that the parser encodes to establish gender agreement, reveal similar gender mechanisms in the two languages.

### Method

#### Participants

The study included three experimental groups, i.e., monolingual controls, Serbian-Greek early and late



successive bilinguals. Twenty Greek-speaking monolinguals (8 males; group mean age: 31.7, *SD*: 6.3; group mean education: 14;5, *SD*: 3.1), 16 Serbian-native early successive bilingual speakers (7 males; group mean age: 24.5, *SD*: 5.2; group mean education: 15;9, *SD*: 1.7) and 16 Serbian-native late successive bilinguals (5 males; group mean age: 29.6, *SD*: 8.1; group mean education: 15;6, *SD*: 1.6) who spoke Greek as an L2 were recruited. The monolinguals and the two bilingual groups were matched on education ( $F(2, 51) = 1.753, p = .184$ ) but not on age; there was a significant age effect ( $F(2, 51) = 5.725, p = .006$ ) which stemmed from the fact the early successive bilingual group was younger than the monolingual participants ( $p = .005$ ). There was no significant age difference between early and late successive bilinguals ( $p = .091$ ) nor between monolinguals and late successive bilinguals ( $p = .613$ ). Monolingual participants were native Greek speakers and had not studied any other language extensively before the age of 12; some of them reported speaking English as a foreign language, but none were functionally fluent in the English language, and none had more than minimal exposure to other foreign languages. The bilingual participants were divided into two groups depending on the age of onset of exposure to the L2, i.e., Greek. The terms early and late successive bilingualism are used to refer to bilinguals who are exposed to the second language before and after the critical period, respectively, in second language acquisition (e.g., Epstein, Flynn & Martohardjono, 1996; Meisel, 2009). All early successive bilinguals were born to a Greek and a Serbian parent; twelve of them were exposed to both languages from birth and four before/at the age of four. On the other hand, the members of the late successive bilingual group had been exposed to Greek as their L2 in adulthood (age  $\geq 22$ ). The overwhelming majority of this group ( $N=14$ ) has been married to Greek citizens and moved to Greece after having finished their undergraduate studies in Serbian universities. Both early and late successive bilingual speakers reported having regular and proficient oral use of both languages on a daily basis. Moreover, both groups reported having high literacy skills in Greek. Several bilingual participants reported knowledge of a third language besides Serbian and Greek (Italian, French, Bulgarian, and Russian) though they rated their proficiency in these languages as much lower than in Serbian and Greek.

Bilinguals were also administered a cloze test (maximum score: 50) that evaluated grammatical knowledge of pronominal clitics in Greek. The production of object clitics constitutes a vulnerable domain for learners of Greek as an L2 - especially for learners whose native language allows the use of null objects in similar contexts, such as Slavic languages (cf. Chondrogianni, 2008; Tsimpli & Mastropavlou, 2007). Based on the learnability challenge presented by clitic placement to

native speakers of Slavic languages, the specific cloze test was used as an index of the Serbian subjects' proficiency in the Greek language. Analyses revealed no significant difference between early and late successive bilinguals' scores in the specific task ( $t(15) = 1.252, p = .230$ ; mean score: 46.7, *SD*: 2.4, range: 42–50 for early successive bilinguals; mean score: 45.6/50, *SD*: 1.8, range: 41–48 for late successive bilinguals).

Finally, all three groups were administered the Raven's Standard Progressive Matrices (SPM) for adults (Raven, 1962). There was no group difference in the non-verbal IQ test ( $F(2, 51) = .583, p = .562$ ). Also, the three groups had similar profiles in terms of sex, handedness, and occupation (see Table 1).

### Experiment 1: Gender Picture-Word Interference Task

#### Materials

We selected 72 black-and-white line drawings of common inanimate objects from the Snodgrass and Vanderwart (1980) object databank with the restriction that superimposing a distractor stimulus would not impair their recognizability. Twenty-four of the pictures corresponded to masculine, 24 to feminine and the remaining 24 to nouns of neuter gender in Greek. Most importantly, half of the pictures in each of the three categories matched the grammatical gender of the corresponding inanimate object in Serbian (Greek/Serbian picture congruency) and the other half did not (Greek/Serbian picture incongruency). For instance, of the 24 masculine nouns in Greek, 12 were masculine, 6 feminine, and 6 neuter in Serbian (see Appendix A for the list of the picture names in Greek and their translational equivalents in Serbian).

Seventy-two additional Greek words were selected as distractors, 24 masculine, 24 feminine and 24 neuter nouns (Mean average frequency per million: Masc. 55.9; Fem. 54.0; Neut. 65.7,  $F(2, 69) = 1.829, p = .168$ ); Mean word length in syllables: Masc. 2.8; Fem. 2.6; Neut. 2.6,  $F(2, 69) = .752, p = .475$ ). Distractor words always shared the same gender across the two languages and they were semantically unrelated to the picture names (see Appendix B for the list of the distractor words in Greek and their translational equivalents in Serbian). Moreover, Greek and Serbian cognate words with varying degrees of orthographic and phonological overlap were excluded from the list of materials in order to avoid any possible cognate facilitation effects. More information on the comparisons of the length and the lexical frequencies between picture names and the distractor words in Greek, as well as their translational equivalents in Serbian, is attached in Appendix C.

Grammatical gender congruency effects in the PWI task were drawn from manipulating two basic dimensions: the Greek picture-word congruency and

Table 1. Group means (SDs) and ranges of participants' socio-demographic traits, Raven's Standard Progressive Matrices Scores, Cloze test proficiency scores in Greek for Serbian participants and extent of language use and self-reported proficiency in each language for Serbian participants

	Monolinguals ( <i>N</i> = 20)	Late successive bilinguals ( <i>N</i> = 16)	Early successive bilinguals ( <i>N</i> = 16)
Age	31;7 (4.9) 22–41	29;6 (8.1) 22–51	24;5 (6.3) 17–39
Years of Education	14;5 (3.1) 9–21	15;6 (1.6) 12–18	15;9 (1.7) 12–18
Mean length of stay in Greece	–	10;6 (3.9) 6–17	23;7 (5.5) 17–35
Non-verbal IQ (Ravens)	50.1 (4.4)	51.3 (4.3)	51.6 (4.9)
Cloze test proficiency scores	–	45.6 (1.8)	46.7 (2.4)
Extent of language use with friends and relatives in Greece	–	3.2 (0.5)	3.4 (0.7)
Self-reported proficiency in Greek	–		
<i>Understanding</i>		4.6 (0.6)	4.7 (0.6)
<i>Speaking</i>		4.6 (0.6)	4.7 (0.5)
<i>Reading</i>		4.7 (0.4)	4.8 (0.3)
<i>Writing</i>		4.4 (0.9)	4.5 (0.6)
Self-reported proficiency in Serbian	–		
<i>Understanding</i>		5.0 (0)	4.9 (0.3)
<i>Speaking</i>		4.9 (0.2)	4.6 (0.6)
<i>Reading</i>		5.0 (0)	4.8 (0.6)
<i>Writing</i>		5.0 (0)	4.5 (0.7)
School Degree	Lower High School (1) High School (2) BA/BSc (9) MA/MSc (7) PhD (1)	High School (2) BA/BSc (10) MA/MSc (4) BA/BSc (9) MA/MSc (7) PhD (1)	High School (2) 9 BA/BSc (9) 5 MA/MSc (5)
Occupation	13 students 6 teachers 1 clerk	13 students 3 teachers	12 students 4 teachers
Sex	8 male/12 female	5 male/11 female	7 male/9 female
Handedness	19 right/1 left	14 right/2 left	15 right/1 left

the Greek/Serbian picture congruency. With respect to the Greek picture-word congruency dimension, this was created by manipulating the target and distractor (in)congruency relationship in the response language, i.e., Greek. As such, pictures were presented with a gender-congruent distractor (Greek picture-word congruent trials), a gender-incongruent distractor (Greek picture-word incongruent trials), or a row of Xs (control trials) (see Figure 1). The labels 'Greek picture-word congruent'-'Greek picture-word incongruent' below the picture-word pairings in Figure 1 refer to the Greek picture-

word congruency relationship between the picture name and the superimposed distractor word in the response language, i.e., Greek. More specifically, the Greek picture-word congruent trials were formed by using a picture name and a distractor word carrying the same gender in the L2/Greek (picture name: *kathreftis*/'mirror'<sub>MASC</sub>, distractor word: *stavros*/'cross'<sub>MASC</sub>). On the other hand, Greek picture-word incongruent trials were formed by using a distractor word that differed from the gender of the picture name; since the Greek language has a three-way gender distinction, two

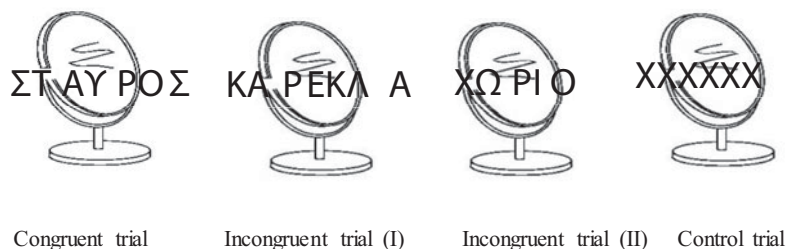

Figure 1. Examples of four picture-word interference displays in the Greek picture-word congruent, incongruent and control trials (σταυρός/‘cross’ is masc. in both Greek and Serbian, karekla/‘chair’ is fem. in both Greek and Serbian, horio/‘village’ is neut. in both Greek and Serbian. Notice: the name of the picture ‘mirror’ is masc. in Greek (kathreftis) and neut. in Serbian (ogledalo)

sets of Greek picture-word incongruent trials were formed: Greek picture-word incongruent trials (set I) (picture name: kathreftis/‘mirror’<sub>MASC</sub>, distractor word: karekla/‘chair’<sub>FEM</sub>) and Greek picture-word incongruent trials (set II) (picture name: kathreftis/‘mirror’<sub>MASC</sub>, distractor word: horio/‘village’<sub>NEUT</sub>).

As already mentioned, apart from the Greek picture-word congruency relationship between the gender of the picture name and the gender of the distractor word in Greek, Greek/Serbian picture congruency, i.e., between-language gender congruencies stemming from the gender feature of the picture name in Greek and its translational equivalent in Serbian were also manipulated to create the following conditions: (1) Greek picture-word and Greek/Serbian picture congruency, whereby there was congruency among the Greek gender of the picture noun, the Serbian gender of the picture noun and the gender of the distractor word, (2) Greek picture-word congruency and Greek/Serbian picture incongruency, whereby there was congruency between the gender of the picture and the gender of the distractor word in Greek, but incongruency between the gender of the picture noun in Serbian and the gender of the distractor word, (3) Greek picture-word incongruency and Greek/Serbian picture congruency, whereby there was incongruency between the gender of the picture noun in Greek and the gender of the distractor, but congruency between the gender of the picture noun in Serbian and the gender of the distractor word, and (4) Greek picture-word and Greek/Serbian picture incongruency, whereby there was incongruency between the gender of the distractor word and the gender of the picture name irrespective of language (see Table 2 for examples per each condition).

Finally, two more conditions were created depending on whether there was incongruency between the gender of the picture word in Greek and its translation in Serbian in the control trials in which the distractor word was replaced by a row of Xs. More specifically: (5) the gender of the picture in Greek was congruent with the gender of its translational equivalent in Serbian (e.g., picture: μπάλα (bala)/‘ball’ (fem.) – лопта (lopta)/‘ball’

(fem.) – distractor: xxxxxx), and, finally, (6) the gender of the picture in Greek was incongruent with the gender of the Serbian noun (e.g., picture: ντομάτα (domata)/‘tomato’ (fem.) – парадајз (paradajz)/ ‘tomato’ (masc.) – distractor: xxxxxx).

None of the resulting picture-word pairings were semantically and/or phonologically related. Three lists were created such that each picture was seen in a Greek picture-word congruent, incongruent and control context but in only one context per list. Each list included 72 test items (i.e., 24 items for each L2 context, i.e., congruent, incongruent, control), and 28 filler trials (fillers were presented only with Xs, not with a distractor word). The order of presentation was pseudo-randomized for each participant with the restriction that no semantically or phonologically related stimuli (either picture names or distractors) occur in five consecutive trials. The picture-word pairs were shown at + 200ms Stimulus Onset Asynchrony (SOA), i.e., the distractor appeared 200ms after the picture appeared on the screen (Foucart, 2008). Though the selection of the determiner form in Greek is not dependent on the phonological features of the local context like in French and Italian (Miozzo & Caramazza, 1999), a number of researchers, like Mastropavlou and Tsimpli (2011), Varlokosta (2011) and Ralli (2002), show that adult native speakers of Greek use morphological information carried by the noun suffix to predict gender, thus, confirming the claim that morphology plays an important role in the assignment of gender to Greek nouns. Assuming that the determiner in Greek is selected as soon as the lemma is selected and morphological information stemming from the noun’s suffix becomes available, the picture-word pairs in the present study were presented at a positive SOA to allow speakers time to gain access to the nouns’ inflectional morphemes.

### Design

The experimental design included the following factors: Greek picture-word Congruency (Greek picture-word congruent, Greek picture-word incongruent) and Greek/Serbian picture Congruency (Greek/Serbian

Table 2. Examples of the picture-word interference conditions created by manipulating, first, Greek picture-word congruency created by the relation between the gender of the picture name and the gender of the distractor word in Greek, and, second, Greek/Serbian picture congruency created by the relation between the gender of the picture name and its translational equivalent in Serbian

Stimuli	Languages	Greek picture-word & Greek/Serbian picture Congruency	Greek picture-word Congruency & Greek/Serbian picture Incongruency	Greek picture-word Incongruency & Greek/Serbian picture Congruency	Greek picture-word & Greek/Serbian picture Incongruency
Picture-name gender	Greek	μπάλα ( <i>bala</i> )/‘ball’ <i>feminine</i>	τομάτα ( <i>domata</i> )/‘tomato’ <i>feminine</i>	παγωτό ( <i>pajoto</i> )/‘ice-cream’ <i>neuter</i>	φωλιά ( <i>folia</i> )/‘nest’ <i>feminine</i>
	Serbian	лопта ( <i>lopta</i> )/‘ball’ <i>feminine</i>	парадајз ( <i>paradajz</i> )/‘tomato’ <i>masculine</i>	сладолед ( <i>sladoled</i> )/‘ice-cream’ <i>masculine</i>	гнездо ( <i>gnezdo</i> )/‘nest’ <i>neuter</i>
Distractor-word gender	Greek	καρέκλα ( <i>karekla</i> )/‘chair’ <i>feminine</i>		φάρος ( <i>faros</i> )/‘lighthouse’ <i>masculine</i>	
	Serbian	столица ( <i>stolica</i> )/‘chair’ <i>feminine</i>		светионик ( <i>svetionik</i> )/‘lighthouse’ <i>masculine</i>	

picture congruent vs. Greek/Serbian picture incongruent) as within-subjects factors, and group (Greek-speaking monolinguals, early Serbian (L1)–Greek (L2) bilinguals, late Serbian (L1)–Greek (L2) bilinguals) as between-subjects factor.

### Apparatus

The stimuli were presented as black line drawings on white background from an Acer computer and the experiment was run using the E-Prime software (Schneider, Eschman & Zuccolotto, 2002). Responses were measured to the nearest millisecond with a microphone (Sennheiser ME40) connected to a voice-response box. Target pictures were enlarged to a size of approximately 18 x 18 cm, and distractor pictures were shrunk to a size of approximately 8 x 8 cm. Distractor words were presented in black uppercase Arial 18 Bold font in the center of each target picture.

### Procedure

Before the experiment proper, all the pictures included in the PWI task were presented in a Power Point file with superimposed Xs to represent the position where the distractor words would appear in the experiment. Participants were required to think of the name they would spontaneously use in Greek to describe the picture they saw on the screen, and then the name (i.e., determiner+noun) they were expected to produce for this particular picture. Successful naming of 90% (i.e., at least 65/72 pictures) of the whole picture set was a prerequisite

for participation in the PWI task. In case Serbian-speaking participants made a gender mistake while naming the pictures, the examiner told them the correct gender. The percentage of times the Serbian-speaking participants made a gender error while naming the pictures in the pretest was very low (Mean: 0.5%), thus, implying that these speakers were highly proficient in their L2 (Greek). Apart from naming the target pictures in Greek, Serbian bilinguals were also asked to name them in Serbian in order to examine whether they would use the intended L1/Serbian word (with the intended grammatical gender feature). Participants’ responses were recorded and a native speaker of Serbian, who was not involved in the tasks, transcribed the data. The Serbian words produced for the target pictures were perceived to converge on 99 percent of the words’ (intended) translational equivalents in Serbian.

The participants were tested individually. Three experimental sessions were carried out, consisting of 100 naming responses each, with a minimum interval of two days between sessions. On-screen written instructions informed the subjects to name the picture in Greek as fast and accurately as possible using a DP sequence and ignore the distractor word. Speed as well as accuracy was emphasized. On each individual trial, the participants first viewed a fixation cross presented at the center of the screen for 500 msec. After a blank interval of 500 msec, the target picture was displayed and the distractor-word, which was either gender-congruent or gender incongruent with the target picture, appeared at the centre of the picture with



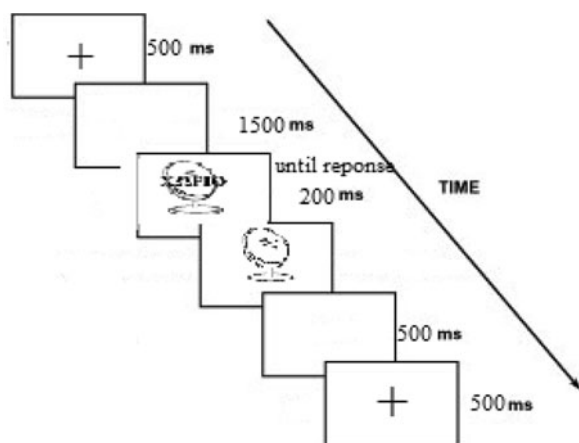

Figure 2. Schematic representation of the event sequence in each trial of the picture-word interference task.

a 200 msec delay. The picture-distractor word pairing would stay on the screen until the verbal response, i.e., the DP, was provided, up to a maximum of 2000ms. The participants performed the naming response on the target picture by speaking the picture label into a microphone from the onset of the produced DP (i.e., determiner + noun). The picture and the distractor stimulus disappeared from the screen as soon as the voice key was triggered. Each trial was concluded by a 1500-msec inter-trial interval (see Figure 2 for a schematic representation of the event sequence of each trial in the task). Each experimental session was preceded by a training session of 10 naming trials, whereby the procedure was exactly the same as the procedure of the experimental phase. The 100 trials per block were the same across participants and were randomized per block with the constraint that stimuli in the same (congruent or incongruent) condition could not appear on more than three consecutive trials.

### Results

Prior to the statistical analysis of the data, responses which were judged by the experimenter as being incorrect (i.e., inappropriate grammatical gender attribution to the determiner, incomplete naming responses, disfluencies that triggered the voice key, and pauses), as well as subject-by-subject latencies which were smaller than 250ms and those over two *SDs* from each participant's mean were removed and replaced by the mean (see Janssen, Schirm, Mahon & Caramazza, 2008; Meyer, 1996; Ratcliff, 1993, among others, for a similar design). This procedure yielded 4.7%, 4.9%, and 1.7% for the Greek-speaking monolingual group, 2.2%, 3.9% and 1.6% for the early successive Serbian-Greek bilingual group, and 3.3%, 3.7% and 3.9% for the late successive Serbian-Greek bilingual group for the Greek picture-word congruent, incongruent and control trials, respectively. Table 3

illustrates that the error rates in the three categories were low across groups. Error rates were submitted to a one-way analysis of variance (ANOVA) with group (Greek-speaking monolinguals, early successive bilinguals, late successive bilinguals) as the between-subjects variable and error rates as the dependent variable; the main effect of the group variable was non-significant in both the subject and the item analysis ( $F(2, 51) = 1.058, p = .355$ ;  $F(2, 71) = 1.060, p = .352$  for the Greek picture-word Congruent trials,  $F(2, 51) = .262, p = .771$ ;  $F(2, 71) = .049, p = .952$  for the Greek picture-word Incongruent trials, and  $F(2, 51) = .005, p = .995$ ;  $F(2, 71) = .196, p = .823$  for the Control trials).

Furthermore, measurements of Pearson Correlation Coefficients were performed to examine the relationships among the RTs of the three experimental blocks of the PWI task. Reaction times on the first experimental block showed significant correlations with the reaction times of the second,  $r=0.762, p < 0.01$ , and the third experimental block,  $r=0.725, p < 0.01$ , while the RTs of the second experimental block also showed a significant correlation with the RTs of the third experimental block,  $r=0.804, p < 0.01$ .

Figure 3 displays the mean response latencies (in msec) varied by experimental group (Greek-speaking monolinguals, early successive bilinguals, late successive bilinguals) and Greek picture-word Congruency (Greek picture-word congruent, incongruent, control) depending on the congruency relationship between the grammatical gender of the picture name in Greek and the gender of the distractor word. Table 4, on the other hand, presents the two bilingual groups' mean response latencies (in msec) in the trials conditioned by the Greek/Serbian picture Congruency factor, i.e., whether the grammatical gender of the picture-name in Greek agreed or not with the gender of the picture-name's translational equivalent in Serbian.

We conducted a repeated measures ANOVA with group (Greek monolinguals, early successive bilinguals, late successive bilinguals) as a between-subjects factor, and Greek picture-word Congruency (Greek picture-word congruent, Greek picture-word incongruent) and Greek/Serbian picture Congruency (Greek/Serbian picture congruent, Greek/Serbian picture incongruent) as within-subjects factors. Both subject ( $F_1$ ) and item ( $F_2$ ) analyses were conducted. An effect of Greek picture-word Congruency was observed<sup>1</sup>;  $F(1, 49) = 11.362, p = .001$ ;

<sup>1</sup> To further elucidate the nature of the mechanisms supporting the processing of grammatical gender in the monolingual and bilingual groups of the present study we examined Greek picture-word congruency effects separately for masculine, feminine, and neuter picture names. We conducted a repeated measures ANOVA with group (Greek monolinguals, early bilinguals, late bilinguals) as a between-subjects factor, gender (masculine, feminine, neuter), and Greek picture-word Congruency (Greek picture-word congruent, Greek picture-word incongruent) as within-subjects factors. A significant

Table 3. Groups' error rates (E%) and standard deviations (SDs) (in msec) in the Greek picture-word congruent, incongruent and control trials of the Gender Picture-Word Interference Task

Group	Experimental Trials		
	Greek picture-word Congruent Mean E% (SD)	Greek picture-word Incongruent Mean E% (SD)	Control Mean E% (SD)
Monolinguals (N = 20)	0.5 (1.4)	0.6 (1.3)	0.3 (0.6)
Early successive bilinguals (2L1) (N = 16)	0.1 (0.25)	0.4 (0.7)	0.3 (0.5)
Late successive bilinguals (L2) (N = 16)	0.4 (0.6)	0.5 (1.0)	0.3 (0.8)

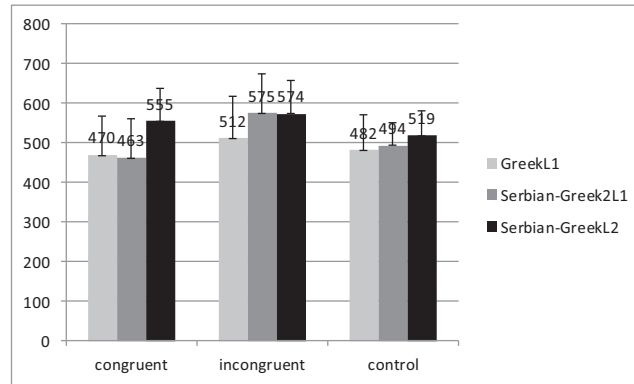

Figure 3. Groups' naming latencies (in msec) in the Gender Picture-Word Interference Task after collapsing over Greek picture-word congruency, i.e. the congruency relationship between the gender of the picture-name and the gender of the distractor-word in the response language (Greek)

Note. GreekL1, monolingual Greek-speaking adults; Serbian-Greek2L1, early successive Serbian-Greek bilingual adults; Serbian-GreekL2, late successive Serbian-Greek bilingual adults.

$F2(1, 105) = 25.967, p < .001$ . There were significant main effects of Greek/Serbian picture Congruency ( $F1(1,$

two-way interaction between Greek picture-word Congruency and gender was observed on both subject-based,  $F1(2, 98) = 2.712, p = .056$ , and item-based,  $F2(2, 138) = 3.753, p = .026$ , analyses. Subsequent paired  $t$ -tests revealed significant Greek picture-word Congruency effects only for masculine and feminine picture-names;  $t(51) = 3.956, p < .001$  for masculine nouns,  $t(51) = 2.992, p = .004$  for feminine nouns, and  $t(51) = .404, p = .688$  for neuter nouns (one-tailed; subject-based data, collapsing across items);  $t(71) = 4.057, p < .001$  for masculine nouns,  $t(71) = 3.364, p = .001$  for feminine nouns, and  $t(71) = .200, p = .842$  for neuter nouns (one-tailed; item-based data, collapsing across subjects). The specific result appears to confirm the default value of the neuter gender in Greek (Tsimpli & Hulk, 2013), as well as its role in neutralizing gender conflicts once word retrieval targets neuter nouns.

$49) = 13.193, p = .001; F2(1, 105) = 25.409, p < .001$ ) and group ( $F1(2, 49) = 112.040, p < .001; F2(2, 105) = 227.602, p < .001$ , respectively); subsequent post-hoc tests revealed that the monolingual group was significantly different from late successive bilinguals ( $p = .034$ ) but not early successive bilinguals ( $p = .591$ ), while the difference between early and late successive bilinguals was not significant either ( $p = .291$ ). The analysis also revealed a significant two-way interaction between group and Greek picture-word Congruency ( $F1(2, 49) = 3.751, p = .031; F2(2, 105) = 4.617, p = .012$ ), and a significant interaction between group and Greek/Serbian picture Congruency ( $F1(2, 49) = 4.791, p = .013; F2(2, 105) = 10.991, p < .001$ ). Finally, there was a significant three-way interaction among group, Greek

Table 4. Early and late successive bilinguals' naming latencies (in msec) (SDs) in the Greek picture-word (in)congruent and Greek/Serbian picture (in)congruent trials of the Gender Picture-Word Interference Task

	Experimental Conditions					
	(1)	(2)	(3)	(4)	(5)	(6)
	Greek picture-word & Greek/Serbian picture Congruency	Greek picture-word & Greek/Serbian picture Incongruency	Greek picture-word & Greek/Serbian picture Congruency	Greek picture-word & Greek/Serbian picture Incongruency	Greek/Serbian picture Congruency Control trials	Greek/Serbian picture Incongruency Control trials
Bilingual group	Mean (SD)	Mean (SD)	Mean (SD)	Mean (SD)	Mean (SD)	Mean (SD)
Early successive bilinguals (2L1) (N = 16)	440 (99.0)	486 (81.3)	548 (82.2)	601 (141.6)	466 (80.4)	522 (125.0)
Late successive bilinguals (L2) (N = 16)	519 (97.6)	592 (145.1)	520 (144.8)	628 (198.4)	491 (130.5)	546 (145.3)

picture-word Congruency, and Greek/Serbian picture Congruency,  $F1(2, 49) = 23.064, p < .001$ ;  $F2(2, 105) = 10.991, p < .001$ .

We next conducted separate repeated measures ANOVAs (Greek picture-word Congruency: (in)congruency relationship between the gender of the picture name and the gender of the distractor word in Greek; Greek/Serbian picture Congruency: (in)congruency relationship between the gender of the picture name in Greek and the gender of the picture name's translational equivalent in Serbian) for each group to search for the source of this interaction. We report on our analysis for the early successive bilingual group first. We observed a significant main effect of Greek picture-word Congruency,  $F1(1, 15) = 20.784, p < .001$ ;  $F2(1, 35) = 46.161, p < .001$ , which was due to the fact that the group's response latencies for the Greek picture-word congruent trials (463 msec) were considerably faster relative to the Greek picture-word incongruent trials (575 msec) (see Figure 3); no significant main effect of Greek/Serbian picture Congruency was observed,  $F1(1, 15) = 3.135, p = .160$ ;  $F2(1, 35) = .249, p = .621$ , since the early successive bilingual group's response latencies for the Greek/Serbian incongruent trials (543 msec, i.e., the average between conditions (2) and (4) in Table 2) were not significantly slower than Greek/Serbian congruent trials (494 msec, i.e., the average between conditions (1) and (3) in Table 2). For the late successive bilingual group, the effects were reversed; there was a significant main effect of Greek/Serbian picture Congruency,  $F1(1, 15) = 7.541, p = .015$ ;  $F2(1, 35) =$

19.960,  $p < .001$ , but no significant main effect of Greek picture-word Congruency,  $F1(1, 15) = .239, p = .632$ ;  $F2(1, 35) = 3.390, p = .080$ . An examination of Table 4 reveals the source of the Greek/Serbian picture Congruency effect for the late successive bilingual group: response latencies for the Greek/Serbian picture incongruent trials (610 msec) were significantly slower than for the Greek/Serbian picture congruent trials (520 msec). The specific results show that the interference effect as indexed by the difference in RTs between Greek/Serbian incongruent and Greek/Serbian congruent trials was nearly double for the late (91 msec) relative to the early successive bilingual group (49 msec). For the monolingual group, a significant main effect of Congruency was observed,  $F1(1, 19) = 8.024, p = .011$ ;  $F2(1, 35) = 8.087, p = .007$ , while the Greek/Serbian picture Congruency effect was not significant,  $F1(1, 19) = 1.330, p = .263$ ;  $F2(1, 35) = 1.896, p = .177$ , as expected. A look at the RT data in Figure 3 reveals that the Congruency effect stemmed from monolinguals' significantly faster RTs in the congruent (470 msec) relative to the incongruent (512 msec) trials.

The next step of data analyses was to examine any Serbian interference effects on the groups' response latencies in the control trials, i.e., the trials where the to-be-named target pictures were presented along a row of Xs superimposed on the target picture. As such, our second repeated measures ANOVA was conducted with group (Greek monolinguals, early successive bilinguals, late successive bilinguals) as a between-subjects factor, and Greek/Serbian picture Congruency (Greek/Serbian

picture congruent, Greek/Serbian picture incongruent) as within-subjects factor. We observed a main effect of Greek/Serbian picture Congruency,  $F_2(1, 105) = 8.376$ ,  $p = .005$  (item-based data; no effect on subject-based data was observed,  $F_1(1, 49) = 2.834$ ,  $p = .099$ ), which stemmed from the fact that RTs for the control trials involving congruency between the gender of the picture name and its translational equivalent in Serbian were significantly faster (476 msecs) than the RTs for the trials involving Greek/Serbian incongruency (516 msecs). No significant group effect ( $F_1(2, 49) = .666$ ,  $p = .519$ ;  $F_2(2, 105) = 1.455$ ,  $p = .238$ ) or interactions between group and Greek/Serbian picture Congruency ( $F_1(2, 49) = .927$ ,  $p = .402$ ;  $F_2(2, 105) = 2.269$ ,  $p = .110$ ) were observed.

### Experiment 2: Non-verbal Spatial Target-Stimulus Locating Task

#### Materials, design, apparatus and procedure

Four horizontal white lines, two on the top and two on the bottom of the black background of the screen served as the stimuli marking the locations in which the target and the possible distractor could appear. The lines remained on the screen for 1500 msecs after which the prime display appeared. After 150 msecs from the prime's onset, the four horizontal lines appeared for 2850 msecs. Half of the participants in each of the three groups were required to report the location of a target ('X') appearing in one of four locations by pressing the corresponding key on the keyboard and to ignore a distractor ('O') that occurred in one of the other three locations (the opposite mapping was assigned to the other half of the participants). Responses consisted of pressing one of four green-labeled keys, each spatially compatible with one of the four marked positions on the screen. After a response was made or the time granted for response elapsed, there was a 350 msecs auditory feedback interval before the critical probe display appeared for 150 msecs. This display could exhibit either the target and the distractor or just the target. The timing procedure was identical to the one used for the prime display.

On the whole, the task included 96 prime-probe combinations divided into two experimental blocks. Prime-probe sequences were manipulated along the prime-probe location relationship, i.e., whether the probe target was presented in the previously inhibited location occupied by the prime distractor (i.e., PRIME-PROBE RELATED TRIALS; NEGATIVE PRIMING EFFECT) as opposed to the trials in which the probe target appeared in a previously empty location on the prime display (PRIME-PROBE UNRELATED TRIALS) (see Figure 4). Latency in the responses (in msecs) and response accuracy (in %) across the prime-probe related and prime-probe unrelated trials

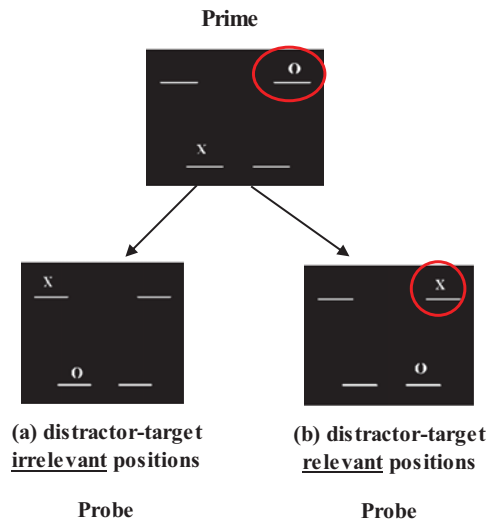

Figure 4. (Colour online) Examples of (a) prime distractor-probe target relevant and (b) prime distractor-probe target irrelevant trials in the non-verbal Spatial Target-Stimulus Locating Task.

were recorded with E-Prime software (Schneider et al., 2002).

#### Results

Reaction times deviating more than two *SDs* from a participant's mean were eliminated and replaced by the mean for each participant (3.95%, 4.12%, and 2.95% of trials for the Greek-speaking monolinguals, early successive bilinguals, and late successive bilinguals, respectively).

We report on our analyses for the RTs first. Our first mixed-design ANOVA was conducted with participants' group (monolinguals, early successive bilinguals, late successive bilinguals) as a between-subjects factor, and prime-probe relationship (prime distractor-probe target related locations vs. prime distractor-probe target unrelated locations) as within-subjects factor. A significant two-way interaction between distractor-target relationship and group ( $F_1(2, 49) = 14.563$ ,  $p < .001$ ;  $F_2(2, 141) = 7.707$ ,  $p = .001$ ) was found, while both group and distractor-target location effects were significant only in the item analyses ( $F_1(2, 49) = .193$ ,  $p = .825$ ;  $F_2(2, 141) = 6.223$ ,  $p = .003$  for the group effect;  $F_1(1, 49) = 1.414$ ,  $p = .238$ ;  $F_2(1, 141) = 35.126$ ,  $p < .001$  for the distractor-target location effect). Separate repeated measures ANOVAs conducted for each group revealed a significant negative priming effect for the monolingual and the early successive bilingual group only ( $F_1(1, 19) = 10.625$ ,  $p = .006$ ;  $F_2(1, 47) = 20.742$ ,  $p < .001$  for monolinguals, and  $F_1(1, 15) = 92.466$ ,  $p < .001$ ;  $F_2(1, 47) = 15.925$ ,  $p < .001$  for early successive bilinguals;  $F_1(1,$



Table 5. Mean Reaction Times (in msec) (SDs) and percentages of errors (SDs) of the experimental groups as a function of Prime-Probe [ $\pm$  Relatedness] in the non-verbal Spatial Target-Stimulus Locating Task

Experimental Group	Prime-Probe Related trials		Prime-Probe Unrelated trials	
	Mean Reaction Times (SDs)	Mean percentages of errors (SDs)	Mean Reaction Times (SDs)	Mean percentages of errors (SDs)
Monolinguals ( $N = 20$ )	476 (123.5)	5.0 (0.7)	398 (102.2)	0.4 (.02)
Early successive bilinguals ( $N = 16$ )	500 (143.7)	1.0 (.03)	403 (124.7)	0
Late successive bilinguals ( $N = 16$ )	411 (164.4)	6.7 (.10)	452 (130.5)	1.0 (.04)

15) = 1.632,  $p = .214$ ;  $F2(1, 47) = 3.925$ ,  $p = .171$  for the late successive bilingual group). As shown in Table 5, the negative priming effect stemmed from monolinguals' and early successive bilinguals' considerably slower response latencies in the distractor-target related trials – where the target in the probe trial occupied a location that has previously been occupied by the distractor – compared to the distractor-target unrelated trials.

The same analyses performed on the percentages of errors showed a significant group effect ( $F1(2, 49) = 2.911$ ,  $p = .054$ ;  $F2(2, 141) = 8.617$ ,  $p < .001$ ), a significant distractor-target location relationship effect ( $F1(1, 49) = 14.226$ ,  $p < .001$ ;  $F2(1, 141) = 47.052$ ,  $p < .001$ ), as well as a significant interaction between distractor-target location relationship and group ( $F1(2, 49) = 3.006$ ,  $p = .046$ ;  $F2(2, 141) = 6.737$ ,  $p = .002$ ). Separate repeated measures ANOVAs conducted for each group revealed a significant distractor-target location relationship effect for monolinguals ( $F1(1, 19) = 6.821$ ,  $p = .017$ ;  $F2(1, 47) = 20.047$ ,  $p < .001$ ) and late successive bilinguals ( $F1(1, 15) = 6.398$ ,  $p = .023$ ;  $F2(1, 47) = 6.714$ ,  $p = .013$ ) which was driven from both groups' more erroneous performance in the distractor-target location related vs. unrelated trials (94.9% vs. 99.6% for monolinguals, and 93.2% vs. 98.9% for late bilinguals) in comparison to early successive bilinguals ( $F1(1, 15) = 2.143$ ,  $p = .164$ ;  $F2(1, 47) = 2.714$ ,  $p = .213$ ) who did not exhibit a significant distractor-target location relationship effect in accuracy.

To further investigate the size of the groups' negative priming effect, i.e., the extent to which the three groups varied in their sensitivity to the spatial relatedness between target and distractor location, we conducted an ANOVA with group as the between-subjects factor (monolinguals, early successive bilinguals, late successive bilinguals) and a negative priming effect size index – based on

the difference between each group's RT and accuracy means in the distractor-related and the distractor-unrelated trials – as the dependent variable. The ANOVA on the groups' RTs revealed a significant group effect ( $F1(2, 51) = 9.667$ ,  $p < .001$ ;  $F2(2, 143) = 7.707$ ,  $p < .001$ ). Subsequent post-hoc evaluations of subject-based data showed that the negative priming effect for late successive bilinguals (-41 msec) was of significantly smaller magnitude as that observed for early successive bilinguals (97 msec) and monolinguals (78 msec) ( $p = .001$  for both differences), while there was no significant difference between early successive bilinguals and monolinguals ( $p = .955$ ). Post-hoc tests on item-based data revealed that the negative priming effect for early successive bilinguals (87 msec) was of significantly larger magnitude relative to both monolinguals (56 msec;  $p = .05$ ) and late successive bilinguals (9 msec;  $p < .001$ ), while the negative priming effect for monolinguals was significantly stronger than late successive bilinguals ( $p < .001$ ).

On the other hand, the ANOVA conducted on the groups' negative priming effect as reflected in the accuracy measure revealed a significant group effect only in the item analysis ( $F1(2, 51) = 1.906$ ,  $p = .160$ ;  $F2(2, 143) = 6.737$ ,  $p = .002$ ). Subsequent post-hoc tests showed that the negative priming effect for monolinguals (4.6%) and late successive bilinguals (5.7%) was of larger magnitude as that observed for early successive bilinguals (1.0%;  $p = .004$  for the difference with monolinguals, and  $p = .005$  for the difference with late successive bilinguals), while there was no significant difference between monolinguals and late successive bilinguals ( $p = .968$ ).

#### Regression analyses: Between Tasks Comparisons

We also conducted linear regression analyses to test the hypothesis that constant language control shapes

cognitive control abilities and, thus, results in more pronounced cognitive control. The selection of the variables was based on our aim to determine whether language control in the gender interference task would predict performance in the non-verbal task and in particular on the distractor-target location related trials of the non-verbal task. In particular, we examined the amount of variance in the negative priming effect accounted for by the Greek picture-word congruency and the Greek/Serbian picture congruency effects in the verbal task. The Greek picture-word congruency effect was expressed as the “gender incongruent minus congruent” RT difference for all three groups, while the Greek/Serbian picture congruency effect was measured as the “between-language incongruent minus between-language congruent” RT difference. The analyses were only conducted on RTs, since the error rates in the PWI task were low (see Table 3).

Regression analyses revealed that monolinguals’ performance in the distractor-target interference (location-related) trials of the non-verbal task was not predicted by either Greek picture-word congruency ( $R^2 = .049$ ,  $R^2_{Adjusted} = .011$ ,  $F(1, 19) = .819$ ,  $p = .379$ ) or Greek/Serbian picture congruency ( $R^2 = .082$ ,  $R^2_{Adjusted} = .031$ ,  $F(1, 19) = 1.606$ ,  $p = .221$ ). The same pattern was observed for the location-unrelated trials of the non-verbal task ( $R^2 = .018$ ,  $R^2_{Adjusted} = .044$ ,  $F(1, 19) = .286$ ,  $p = .600$  for Greek picture-word congruency;  $R^2 = .056$ ,  $R^2_{Adjusted} = .004$ ,  $F(1, 19) = 1.072$ ,  $p = .314$  for Greek/Serbian picture congruency).

Considering early successive bilinguals, performance in the prime-probe related trials was significantly predicted by both Greek picture-word congruency ( $R^2 = .541$ ,  $R^2_{Adjusted} = .508$ ,  $F(1, 15) = 16.475$ ,  $p = .001$ ) and Greek/Serbian picture congruency ( $R^2 = .304$ ,  $R^2_{Adjusted} = .255$ ,  $F(1, 15) = 6.129$ ,  $p = .027$ ); specifically, 54.1% and 30.4% of the variance in the non-verbal task was accounted for by the Greek picture-word and the Greek/Serbian picture congruency effect, respectively (subject-based data, collapsing across items). For late successive bilinguals, performance in the prime-probe related trials was not predicted by either Greek picture-word congruency ( $R^2 = .18$ ,  $R^2_{Adjusted} = .012$ ,  $F(1, 15) = 3.209$ ,  $p = .095$ ) or Greek/Serbian picture congruency ( $R^2 = .041$ ,  $R^2_{Adjusted} = .027$ ,  $F(1, 15) = .599$ ,  $p = .452$ ).

Finally, the performance of the two bilingual groups in the prime-probe unrelated trials of the task was not found to be predicted by either Greek picture-word congruency ( $R^2 = .061$ ,  $R^2_{Adjusted} = .006$ ,  $F(1, 15) = .906$ ,  $p = .357$  for late successive bilinguals;  $R^2 = .004$ ,  $R^2_{Adjusted} = .073$ ,  $F(1, 15) = .052$ ,  $p = .824$  for early successive bilinguals) or Greek/Serbian picture congruency ( $R^2 = .000$ ,  $R^2_{Adjusted} = .071$ ,  $F(1, 15) = .000$ ,  $p = .988$  for late successive bilinguals;  $R^2 = .001$ ,  $R^2_{Adjusted} =$

$.076$ ,  $F(1, 15) = .007$ ,  $p = .935$  for early successive bilinguals).

## Discussion

The present study aimed at comparing early and late successive Serbian (L1)–Greek (L2) bilinguals along their efficiency of inhibitory control at both language and non-verbal cognitive domains. We used a picture naming paradigm that prompted both within- and between-language conflict at the grammatical gender level. Inhibition at the non-verbal level was measured by evaluating groups’ performance on a spatial target-stimulus locating task that tested negative priming effects indexed by participants’ RTs and accuracy performance in trials where the target-stimulus appeared in a location that had previously been occupied by the distractor. In the verbal interference experiment we found that late successive bilinguals were more susceptible than early successive bilinguals to grammatical gender interference from their mother tongue. Moreover, early successive bilinguals (along with monolinguals) exhibited a significant Greek picture-word interference effect in contrast to late successive bilinguals whose response latencies in the Greek picture-word incongruent trials did not differ from congruent trials. With respect to the non-verbal task, early successive bilinguals showed a stronger negative priming effect in their RTs compared to late successive bilinguals; yet they exhibited significantly fewer errors in the prime-probe related condition relative to both monolinguals and late successive bilinguals. Moreover, the linear regression analyses indicated that language control, inferred from the size of interference effect in gender-incongruent trials within Greek as well as in the trials inflicting conflict between the picture-word’s grammatical gender in Greek and its translational equivalent in Serbian, significantly predicted performance in the cognitive interference task only for early successive bilinguals.

More specifically, language control in the PWI task was established by measuring processing costs caused, first, by gender congruency effects between the picture and the word in the response language, i.e., Greek, and, second, by L1-L2 congruency effects generated by manipulating the congruency relationship between the gender of the pictured noun in Greek and Serbian. The pattern of performance observed for monolingual speakers confirms the gender congruency effect also found in other studies (La Heij et al., 1998; Schriefers, 1993; Schiller & Caramazza, 2003; Costa et al., 2003); monolingual speakers were slower in producing noun phrases when the distractor word had a different gender from the gender of the target picture compared to the same-gender trials.

In our study, early successive bilinguals showed no between-language congruency effects in both the distractor-present and the control trials of the PWI task in which the target-pictures were not accompanied by a distractor word. More specifically, early successive bilinguals' naming latencies in the trials where the gender of the picture in Greek and the gender of the picture's translational equivalent in Serbian were incongruent and a distractor word was present, were not slower than in the trials where the genders were congruent. In fact, the size of the interference effect from the gender system of the Serbian language in the distractor-present trials of the PWI task was 49 msec, which was very close to the size of the interference effect (i.e., 56 msec) that early successive bilinguals experienced while naming pictures which were not accompanied by a distractor word. On the contrary, late successive bilinguals demonstrated a cross-linguistic gender congruency effect, which was nearly double in size (i.e., 91 msec) relative to that in early successive bilinguals, when naming pictures with superimposed distractor words. Crucially, the RT difference (i.e., 55 msec) between the Greek/Serbian congruent and the Greek/Serbian incongruent condition for the late successive bilingual group in the task's control trials was considerably lower than the interference effect in the distractor-present trials and almost equal to the congruency effect that early successive bilinguals exhibited in the control trials (see Table 4). Since the interaction between L1-L2 congruency and group was not statistically significant for the control trials, the pattern of performance in the PWI indicates that late successive bilinguals were different from early successive bilinguals in showing conflict costs for the trials in which the gender of the picture-noun did not agree with the gender of the picture's translational equivalent in Serbian, yet only for the picture trials with a distractor word. Such discrepancy in late successive bilinguals, i.e., the emergence of between-language congruency in the distractor-present, but not in the distractor-absent trials, implies that the written text superimposed on the target-picture may have increased the activation of the picture's translational equivalent in Serbian, thus leading to the development of conflict between the gender features of Greek and Serbian, as indexed by the considerable Greek/Serbian picture congruency effect. It seems that late successive bilinguals' access to the written form of the Greek distractor word (and, more specifically, to the word's inflectional suffix carrying grammatical gender information) also activated the word's translational equivalent in Serbian, thus strengthening the competition between the Greek and the Serbian gender, at least in the Greek/Serbian picture incongruent trials. At the level of lexical processing, late successive bilinguals were more sensitive than early successive bilinguals to the grammatical gender of the target distractor word

in the presence of the inflectional suffix that activated the gender of the distractor word in both languages. The absence of between-language conflict in the control trials implies that the lexical nodes of the picture words in Greek and Serbian did not act as lexical competitors during picture naming when the written form of the distractor word was absent. Overall, the results suggest that late successive bilinguals experienced stronger interference from the activated lexical items in the non-response language compared to early bilinguals and, most importantly, that mechanisms responsible for the inhibition of gender competitors in Serbian – if in use – were not effective enough to avoid suppression costs.

The results are consistent with the gender-shared models of bilingual language production, which claim that the L1 and L2 gender systems are not separate but interact in the bilingual mental lexicon during language production (La Heij et al., 1998; Levelt et al., 1999; Roelofs, 1998). Lexical items appear to preserve their strong interrelations across languages even in speakers with high L2 proficiency, at least for pairs of languages that have symmetrical grammatical gender systems (i.e., they share type of gender values) like Greek and Serbian, which were the languages examined in the present study. Late successive bilinguals' weakened resistance to information stemming from the non-response language in the PWI task appears to corroborate earlier studies in demonstrating that during a naming task parallel lexical representations are activated even when only one language is needed for naming and that this parallel activation includes the feature of gender (Bordag & Pechmann, 2007; Ganushchak et al., 2011; Kroff, Coffman, Dussias, Gerfen, Gullifer & Guzzardo-Tamargo, 2010; Morales et al., 2011). In a nutshell, the gender retrieval process in Greek for the late Serbian-speaking bilinguals can be thought of as a race where both lexical items across languages are activated, and delay in gender retrieval accuracy is determined by the gender congruency relation between the two languages. Conflict between the gender features of a lexical item across the two languages lowers the activation of the target item, which in turn leads to an increase of the average retrieval time in picture naming.

Costa et al.'s (2003) study with highly proficient Croatian-Italian bilinguals, however, showed that their naming latencies for pictures whose translational equivalents in the L2 had the same gender value as the L1 names (and for pictures with different gender values across the two languages) were similar. As such, Costa et al.'s (2003) study provides no evidence in favor of inter-language interaction at the grammatical gender level. Since the onset of the L2 acquisition in Costa et al.'s (2003) sample of Croatian-Italian bilinguals varied from 5 to 9 years, our knowledge of the effect of onset of

exposure to the L2 on bilinguals' language control abilities cannot be clearly evaluated. Spanish–French bilingual participants in Foucart's (2008) study, on the other hand, were late bilingual adult students, while their precise onset of exposure to French is unspecified. The absence of interlingual interaction at the gender level in both these studies suggests that age of onset of exposure to the L2 may alter the dynamics of cross-language activation of grammatical gender features in bilinguals. Late successive bilinguals in the present study were a more cohesive group relative to previous studies, in the sense that they were all first exposed to Greek after the age of 22; thus they all had a highly functioning procedural L1 system. It is possible that setting the threshold that triggers interaction between the grammatical gender features of the two languages critically relies on the bilinguals' age of the exposure to the L2, and that late age (>20 yrs.) at onset of exposure to the L2 exacerbates cross-language conflict at the grammatical gender level. Moreover, the fact that neither of the studies (i.e., Costa et al., 2003; Foucart, 2008) that have examined interlingual competition has included a task measuring inhibition may have obscured the contribution of bilingual participants' cognitive control abilities to their performance in the gender interference tasks.

When age of acquisition was manipulated in the present study, we found that very early exposure to the L2 plays an important role in regulating competition between conflicting gender features during naming. We would like to entertain two possibilities for the difference between the performances of early and late successive bilingual speakers. On the one hand, it may imply that that the intended language, along with its grammatical gender specifications, were automatically selected due to bilinguals' high proficiency in the L2 (Costa & Santesteban, 2004). It is possible that early successive bilinguals activated the two languages in parallel, so that the parser could evaluate the gender properties of the response language only. On the other hand, the asymmetric cost obtained by the two bilingual groups may reflect greater efficiency to inhibit L1 gender for early successive bilinguals. Proficiency has been found to affect the form that grammatical gender interactions take in bilinguals, and early bilinguals with high literacy levels in both languages are less likely to reveal asymmetrical costs when asked to switch between the two languages because efficient inhibition is applied to the two languages depending on the linguistic context in which bilinguals participate (Costa, Santesteban & Ivanova, 2006). Early successive bilinguals in the present study may have been more efficient in inhibiting interfering co-activated information from their mother tongue than late successive bilinguals. Therefore, the weak L2 gender interference effect in early successive bilinguals may be interpreted as indicating that gender-incongruent

competitors in Serbian were more effectively inhibited by the early bilingual group relative to late successive bilinguals.

At first glance, the presence of a strong interference effect in early successive bilinguals' (and monolinguals') performance in the task's Greek picture-word incongruent trials speaks against a better selection/inhibition mechanism for the specific group. Together, the presence of processing cost associated with interference from gender-incongruent distractors in Greek and the lack of cost for the between-language interaction results suggests that the precise nature of inhibition for early successive bilinguals was specific to between- but not within-language operations at the grammatical gender level. However, the observed strong predictive relation between early successive bilinguals' within- and between-language interference effect in the PWI task and the non-verbal interference effect in the spatial task as revealed by the regression analyses challenges an otherwise tempting account based on the level of inhibition's computational specificity.

One possible explanation for the discrepancy in performance between Greek picture-word incongruent and Greek/Serbian incongruent trials in early successive bilinguals is that knowledge of Greek gender was subject to different memory mechanisms in early compared to late successive bilinguals. The presence of processing cost stemming from Greek picture-word incongruency in early bilinguals (as well as monolinguals) implies that only this group relied on native-like processing mechanisms, possibly related to the procedural consolidation of grammatical gender knowledge in the L2 (Ullman, 2001, 2005). The L2 lexical network in early successive bilingual participants was probably denser than in late successive bilinguals and implicit/intuitive enough to minimize any inhibition demand. As such, the strong Greek picture-word congruency effect in early successive bilinguals may reflect automaticity in gender processing in the non-native language which is associated with the earliness of onset of L2 acquisition and the proceduralization (or else consolidation) of L2 grammatical gender competence for the specific group. On the other hand, if the late bilingual group relied on declarative memory-based explicit knowledge for picture naming in the L2 (i.e., paying attention to whether their DP output would be consistent with the morpho-phonological rules they have learnt) this could simply take precedence over, and block any, L2 grammatical gender interference. Crucially, late successive bilinguals' overreliance on declarative memory-based explicit knowledge for picture naming in the L2 may account for the lack of a congruency effect in Greek. If late bilinguals relied on analytical-logical deliberation enforced by rule-following, they might have taken longer to activate the gender of the distractor in their L2 which



cancelled out competition with the gender of the picture and therefore rendered invisible a gender congruency effect.

Late learners' tendency to apply declarative knowledge of grammar to syntactic processing in the second language has been confirmed by neuroimaging measures. In a study of regular and irregular verb processing in Spanish, Hernández, Hofmann and Kotz (2007) found that late second language learners exhibit increased left inferior frontal gyrus activity as compared to early learners of Spanish of matched proficiency. Furthermore, activity in the prefrontal cortex was significantly higher in the late bilingual group compared to the early one, suggesting that additional syntactic processing was requested when late bilinguals were confronted with L2 irregular items that had to be retrieved from declarative memory (Ullman, Corkin, Coppola, Hickok, Growdon, Koroshetz & Pinker, 1997). The asymmetric cost experienced by the early and late successive bilingual speakers, when naming pictures whose gender in Greek conflicts with the pictures' gender properties in the bilinguals' first language, fits within a growing body of work on how age of acquisition influences brain structures in bilinguals. While children use basic level or sensorimotor mechanisms to learn L2, late or low proficiency bilinguals require additional higher-level processing reflected in the recruitment of more extensive left hemisphere regions in contrast to early bilinguals who tend to recruit basic level linguistic information processing regions (Bloch, Kaiser, Kuenzli, Zappatore, Haller, Franceschini, Luedi, Radue & Nitsch, 2009; Hernández & Li, 2007). The current results on the distinct patterns of grammatical gender processing of early and late bilinguals provide support that syntactic processing in bilinguals shows effects of age of onset of exposure to the L2.

The spatial target-stimulus locating task focused on the groups' cognitive control abilities by exploring their performance in conditions where the locations occupied by the distractor and the target in the prime and probe trials, respectively, were the same or not. The analyses of early successive bilinguals' and monolinguals' RTs across prime-probe related trials indicated that processing costs incurred by the 'long-lived' distractor inhibition effect survived over the probe trial when the target occupied its location. The presence of a significant negative priming effect in the RT performance of monolinguals replicates previous studies on monolingual subjects' tendency to put more effort in reactivating the representation of a stimulus from its inhibited state (Treccani et al., 2009; Amso & Johnson, 2005; Buckolz, Edgar, Kajaste, Lok & Khan, 2012). The finding (at least, in the by-item analysis) that early successive bilinguals had a significantly larger negative priming effect than monolinguals suggests that the specific group had more cognitive resources available and, thus, was able to spend more time to reactivate the

inhibited target stimulus which was suppressed due to the inhibition spread from the prime distractor to the probe target occupying a distractor-related position. A significant negative priming effect was also elicited by monolinguals' and late successive bilinguals' significantly less accurate performance in the prime-probe related (vs. unrelated) trials, but not in early successive bilinguals; such finding implies that early bilingual participants were better able to withhold strong inhibition acting on the target stimulus when performing their motor responses in the task.

The finding that early successive bilinguals differed from monolinguals in the size of the negative priming effect appears to align with Treccani et al.'s study (2009), though, a stronger negative priming effect was exhibited by early bilinguals in Treccani et al. (2009) in the accuracy but not in the RT measure. The fact that the bilingual groups across the present study and Treccani et al. (2009) are not directly comparable, i.e., not all bilinguals in the latter study were exposed to both languages from birth, may have affected the pattern of performance. The asymmetry between the two studies may also be attributed to the early bilingual group's greater emphasis on accuracy rather than on the speed of responding in the present study. Placing emphasis on one of the two measures has been shown to have distinct performance effects on the patterns of the negative priming effect observed in similar tasks, with emphasis on the accuracy of responding leading to robust negative priming effects in RTs but not in accuracy (Neill & Westberry, 1987; Neumann & DeSchepper, 1992). Although we did not find a significant negative priming effect in early successive bilinguals' accuracy performance, RTs may be sufficiently sensitive to detect such an effect. Taken together, early successive bilinguals' stronger negative priming effect in RTs relative to monolinguals and late successive bilinguals suggests that early bilinguals had relatively more efficient inhibitory control mechanisms than the rest of the groups.

According to the results of the linear regression analyses, late successive bilinguals' performance aligned to the performance of the monolingual group, with language control performance in the PWI task failing to predict cognitive control performance in the non-verbal task for either group. On the contrary, early bilinguals' interference effect in the PWI task was found to be a significant predictor of their response latencies in the prime-probe related trials of the non-verbal task, suggesting a link between language control and non-verbal inhibitory processes only for early bilinguals. This result supports the claim that there may be transferability of impact from language control to general-purpose inhibitory control processes, which potentially stems from early successive bilinguals' constant practice of inhibitory control from a very early age to choose which language

they need to respond in (e.g., Blumenfeld & Marian, 2013).

If the length of simultaneous exposure to two languages is critical for more efficient inhibitory control processes to emerge, then early successive bilinguals operate differently from late successive bilinguals. The difference in the size of the negative priming effects exhibited by late and early successive bilinguals suggests unequal levels of cognitive resources for the two groups. The evidence from the regression analyses examining possible interactions between language and cognitive control processes expands on Foucart's (2008) and Costa and colleagues' (2003, 2004, 2006) findings with bilinguals showing that inhibitory mechanisms modulated by the onset of exposure to L2 may play a significant role in language interference resolution. These results further highlight the need to contextualize the naming patterns of bilingual individuals within studies on bilingual non-verbal inhibitory control and on bilingual groups with different ages of onset of exposure to the second language.

A limitation of the present study is that apart from the clitic elicitation task in Greek, the proficiency of the two bilingual groups in Greek was not thoroughly evaluated. Though both groups orally reported high proficiency of reading and speaking in Greek, subtle differences in Greek proficiency might have existed that affected their naming performance in the PWI naming task. Future studies

should seek to explore the influence of both age of onset of exposure and proficiency effects in L2 grammatical gender processing.

## Conclusions

Taken together, these results provide experimental support for the shared gender hypothesis in bilingual production according to which gender representations are shared across L1 and L2 in bilinguals. Furthermore, the results of the present study indicate that there is an age of L2 acquisition effect on diverging grammatical gender systems between the two languages in bilingual adults, with later exposure to the L2 favoring stronger grammatical gender interference from the L1. The strength of interference appears to be modulated by the bilingual groups' inhibition abilities. The data from the non-verbal task suggest that early successive bilinguals had more enhanced inhibitory functions compared to late successive bilinguals and monolinguals. The findings imply that inhibition is potentially operative in contexts that trigger the resolution of grammatical gender conflict between two languages; though other factors such as late successive bilinguals' overreliance on declarative memory-explicit knowledge while assigning grammatical gender in the L2 might also account for their performance difference from early successive bilinguals.

## Appendices

## Appendix A. Picture names in Greek and their translational equivalents in Serbian in the Gender Picture-Word Interference Task

## Picture names of masculine gender in Greek – feminine/neuter gender in Serbian

Greek picture names (masculine)	phonetic transcription in Greek	Serbian translations	phonetic transcription in Serbian	Gender in Serbian
φάκoς/‘flashlight’	fakos	бaтepиja	baterija	feminine gender in Serbian ( <i>N</i> = 6)
βράχoς/‘rock’	vrahos	cтeнa	stena	
φράκτης/‘fence’	fraktis	oγpaдa	ograda	
μύλoς/‘windmill’	milos	вeтpeњaчa	vetrenjača	
κουβάς/‘bucket’	kuvas	кoфa	kofa	
κύβoς/‘cube’	kivos	кoцкa	kocka	
cтyλός/‘pen’	stilos	пepo	pero	neuter gender in Serbian ( <i>N</i> = 6)
λaιμός/‘neck’	lemos	гpлo	grlo	
oupaνός/‘sky’	uranos	нeбo	nebo	
καθρέφτης/‘mirror’	kaθpeftis	oγлeдaлo	ogledalo	
ώμoς/‘shoulder’	omos	paмe	rame	
ήλιoς/‘sun’	ilios	cyнцe	sunce	

## Picture names of feminine gender in Greek – masculine/neuter gender in Serbian

Greek picture names (feminine)	phonetic transcription in Greek	Serbian translations	phonetic transcription in Serbian	Gender in Serbian
ντομάτa/‘tomato’	domata	пapaдajз	paradajz	masculine gender in Serbian ( <i>N</i> = 6)
oμπpέλa/‘umbrella’	ombrela	кишoбpaн	kišobran	
πλατείa/‘square’	platia	тpг	trg	
γωνία/‘corner’	jonía	yгao	ugao	
σκεπή/‘roof’	skēpi	кpoв	krov	
ζώνη/‘belt’	zoni	пoяc	pojas	
λάcπη/‘mud’	laspi	блaтo	blato	neuter gender in Serbian ( <i>N</i> = 6)
λίμνη/‘lake’	limni	jeзepo	jezero	
φωλιά/‘nest’	folia	гнeздo	gnezdo	
καρδιά/‘heart’	karđia	cpцe	srce	
κουβέpтa/‘blanket’	kuverta	ћeбe	cebe	
θάλαccα/‘sea’	thalasa	мopе	more	

## Picture names of neuter gender in Greek - masculine/feminine gender in Serbian

Greek picture names (neuter)	phonetic transcription in Greek	Serbian translations	phonetic transcription in Serbian	Gender in Serbian
αεροπλάνο/'plane'	aeroplano	авион	avion	masculine gender in Serbian ( <i>N</i> = 6)
φτυάρι/'shovel'	ftjiari	ашов	ašov	
αμύγδαλο/'almond'	amijđalo	бадем	badem	
τρένο/'train'	treno	воз	voz	
παγωτό/'ice-cream'	pajoto	сладолед	sladoled	
χιόνι/'snow'	hioni	снег	sneg	
σπίτι/'house'	spiti	кућа	kuća	feminine gender in Serbian ( <i>N</i> = 6)
αλάτι/'salt'	alati	со	so	
τριαντάφυλλο/'rose'	triadafilo	ружа	ruža	
άγαλμα/'statue'	ajalma	статуа	statua	
άχυρο/'straw'	ahiro	слама	slama	
μολύβι/'pencil'	molivi	оловка	olovka	

## Masculine picture names in both Serbian and Greek

Greek picture names (masculine)	phonetic transcription in Greek	Serbian translations (masculine)	phonetic transcription in Serbian
φάκελος/'envelope'	fakelos	коверат	koverat
δρόμος/'road'	đromos	пут	put
ανεμιστήρας/'fan'	anemistiras	вентилатор	ventilator
καταράκτης/'waterfall'	kataraktis	водопад	vodopad
τάφος/'tomb'	tafos	гроб	grob
τοίχος/'wall'	tihos	зид	zid
θάμνος/'bush'	thamnos	грм	grm
καναπές/'couch'	kanapes	кауч	kauč
υπολογιστής/'computer'	ipolojistis	рачунар	računar
χαρταετός/'kite'	hartaetos	змај	zmaj
κόμπος/'knot'	kombos	чвор	čvor
αγκώνας/'elbow'	agonas	лаќат	lakat

## Feminine picture names in both Serbian and Greek

Greek picture names (feminine)	phonetic transcription in Greek	Serbian translations (feminine)	phonetic transcription in Serbian
κολοκύθα/'pumpkin'	kolokiθa	бундева	bundeva
κουρτίνα/'curtain'	kurtina	завеса	zavesa
μπάλα/'ball'	bala	лопта	lopta
κρεμάστρα/'hanger'	kremastra	вешалица	vešalica
φωτιά/'fire'	fotjia	ватра	vatra
κλειδαριά/'locker'	kliđarjia	брава	brava
κούνια/'swing'	kunia	љуљашка	ljuljaška
κεραία/'antenna'	kerea	антена	antena
εκκλησία/'church'	eκληisia	црква	crkva
αγκινάρα/'artichoke'	aginara	артичока	artičoka
σκούπα/'broom'	skupa	метла	metla
βούρτσα/'brush'	vurtsa	четка	četka



## Neuter picture names in both Serbian and Greek

Greek picture names (neuter)	phonetic transcription in Greek	Serbian translations (neuter)	phonetic transcription in Serbian
μάτι/'eye'	mati	око	oko
σταφύλι/'grape'	stafili	грожђе	grožđe
νησί/'island'	nisi	острво	ostrvo
κουμπί/'button'	kubi	дугме	dugme
γόνατο/'knee'	jonato	колeно	koleno
αυγό/'egg'	avjo	јаје	jaje
αυτί/'ear'	afti	уво	uvo
ακόντιο/'javelin'	akodio	копље	köplje
φτερό/'wing'	ftero	крило	krilo
βαρέλι/'barrel'	vareli	буре	bure
κρασί/'wine'	krasi	вино	vino
σχοινί/'rope'	shini	уже	uže

## Appendix B. Distractor words in Greek and their translational equivalents in Serbian in the Gender Picture-Word Interference Task

## Masculine distractor words in both Greek and Serbian

Greek distractor words (masculine)	phonetic transcription in Greek	Serbian translations (masculine)	phonetic transcription in Serbian
συναγερμός/'alarm'	sinajermos	аларм	alarm
ήχος/'sound'	iχos	звук	zvuk
σεισμός/'earthquake'	sismos	земљотрес	zemljotres
ιδρώτας/'sweat'	idrotas	зnoj	znoj
βήχας/'cough'	viχas	кашаљ	kašalj
διάδρομος/'corridor'	diadromos	коридор	koridor
κεραυνός/'thunder'	keravnos	гром	grom
σταυρός/'cross'	stavros	крст	krst
πάγος/'ice'	pagos	лед	led
όροφος/'floor'	orofos	спрат	sprät
σκελετός/'skeleton'	skeletos	костур	kostur
παράδεισος/'paradise'	paradisos	рај	raj
μήνας/'month'	minas	месец	mèsec
φάρος/'lighthouse'	faros	светионик	svetionik
νότος/'south'	notos	југ	jüg
χάρακας/'ruler'	harakas	лењир	lenjir
αριθμός/'number'	aríthmos	број	broj
καπνός/'smoke'	kapnos	дим	dim
αντίχειρας/'thumb'	adihiras	палац	palac
τριποδός/'tripod'	tripodas	троножац	tronožac
τόμος/'volume'	tomos	обим	obim
ουρανοξύστης/'skyscraper'	uranoksistis	облакодер	oblakoder
αέρας/'air'	aceras	ветар	vetar
χυμός/'juice'	himos	сок	sok

## Feminine distractor words in both Greek and Serbian

Greek distractor words (feminine)	phonetic transcription in Greek	Serbian translations (feminine)	phonetic transcription in Serbian
σκηνή/‘scene’	skini	сцèна	scèna
ελιά/‘olive’	ełja	маслина	maslina
τσίχλα/‘gum’	tsihla	жвака	žvaka
τάξη/‘class’	taksi	κласα	klasa
ζέστη/‘heat’	zesti	топлота	toplota
παγίδα/‘trap’	pajida	замка	zamka
βελόνα/‘needle’	velona	игла	igla
φράουλα/‘strawberry’	fraula	јагода	jagoda
σπηλιά/‘cave’	spilia	пећина	pećina
μπανιέρα/‘bathtub’	banjera	када	kada
ομελέτα/‘omelette’	omeleta	кајгана	kajgana
σταγόνα/‘drop’	stayona	кап	kap
σακούλα/‘bag’	sakula	кеса	kesa
βροχή/‘rain’	vrohi	киша	kiša
δύναμη/‘power’	dinami	снага	snága
куψέλη/‘hive’	kipseli	кошница	košnica
κιμωλία/‘chalk’	kimolia	κρεда	kreda
καρέκλα/‘chair’	karekla	столица	stolica
μπότα/‘boot’	bota	чизма	čizma
σκόνη/‘dust’	skoni	прашина	prašina
ιστορία/‘story’	istoria	прича	priča
έρημος/‘desert’	erimos	пустиња	pustara
πάνα/‘diaper’	pana	пелена	pelena
κούκλα/‘doll’	kukla	лутка	lutka

## Neuter distractor words in both Greek and Serbian

Greek distractor words (neuter)	phonetic transcription in Greek	Serbian translations (neuter)	phonetic transcription in Serbian
φως/‘light’	fos	светло	svetlo
πρωί/‘morning’	proi	јутро	juťro
σίδηρο/‘iron’	sidero	гвожђе	gvoždє
σκουπίδι/‘rubbish’	skupidi	ђубре	đubre
όνομα/‘name’	onoma	име	ime
κοπάδι/‘flock’	kopađi	стадо	stado
καλοκαίρι/‘summer’	kalokeri	лето	leto
πρόσωπο/‘face’	prosopo	лице	lice
μελάνι/‘ink’	melani	мастило	mastilo
κρέας/‘meat’	kreas	месо	meso
γάλα/‘milk’	gala	млеко	mleko
πανί/‘sail’	pani	једρο	jedro
έντερο/‘gut’	edero	црево	crevo
γράμμα/‘letter’	grama	πismo	pismo
ποτό/‘drink’	poto	пиће	piće

φρούτο/‘fruit’	frouto	воће	vòće
λιμάνι/‘harbor’	limani	пристаниште	pristaniste
χωρό/‘village’	horjio	село	selo
χωράφι/‘field’	horafi	поље	polje
ταξίδι/‘journey’	taksiði	путовање	putovánje
θέατρο/‘theatre’	theatro	позориште	pozorište
σώμα/‘body’	soma	тело	tělo
χώμα/‘soil’	homa	тло	tlo
απόγευμα/‘afternoon’	apojevma	поподне	popodne

Appendix C. Comparisons of the length and the lexical frequencies of the picture names and distractor words in Greek, as well as their translational equivalents in Serbian across the congruent and incongruent trials of the Gender Picture-Word Interference Task

Picture names in Greek were balanced in frequency and length separately for the Greek/Serbian picture congruent (Mean frequency per million: Masc. 70.2; Fem. 55.9; Neut. 79.5,  $F(2, 35) = .098$ ,  $p = .907$ ); Mean word length in syllables: Masc. 3.0; Fem. 2.8; Neut. 2.4,  $F(2, 35) = 1.454$ ,  $p = .248$ ; Institute for Language and Speech Processing (ILSP) database, [www.ilsp.gr](http://www.ilsp.gr)), and the Greek/Serbian picture incongruent trials (Mean frequency per million: Masc. 44.9; Fem. 61.6; Neut. 79.1,  $F(2, 35) = .816$ ,  $p = .451$ ); Mean word length in syllables: Masc. 2.2; Fem. 2.5; Neut. 2.7,  $F(2, 35) = 2.650$ ,  $p = .089$ ). There were no significant frequency differences between the Greek/Serbian picture congruent and the Greek/Serbian picture incongruent trials for either gender category in Greek ( $F(1, 23) = .343$ ,  $p = .564$  for masculine pictures;  $F(1, 23) = 2.859$ ,  $p = .138$  for feminine pictures;  $F(1, 23) = .387$ ,  $p = .540$  for neuter pictures). Pictures’ translational equivalents in Serbian were balanced only for length since no lemma/surface frequency database has been yet compiled for the Serbian language (Greek/Serbian picture congruent trials: Mean word length in syllables: Masc. 2.7; Fem. 2.8; Neut. 2.3,  $F(2, 35) = 1.027$ ,  $p = .369$ ; Greek/Serbian picture incongruent trials: Mean word length in syllables: Masc. 2.0; Fem. 2.5; Neut. 2.3,  $F(2, 35) = .666$ ,  $p = .521$ ). Paired t-tests on the pictured words’ length for each gender category revealed no significant differences between languages ( $t(23) = 1.273$ ,  $p = .216$  for masculine pictures;  $t(23) = 1.310$ ,  $p = .203$  for feminine pictures;  $t(23) = 2.762$ ,  $p = .012$  for neuter pictures).

Distractor words’ translational equivalents in Serbian were also balanced for length across the three genders (Mean word length in syllables: Masc. 2.2; Fem. 2.4; Neut. 2.6,  $F(2, 69) = 1.273$ ,  $p = .286$ ). Paired t-tests on the distractor words’ length for each gender category revealed no significant differences between languages ( $t(23) = 2.035$ ,  $p = .076$  for masculine distractors;  $t(23) = 1.366$ ,

$p = .185$  for feminine distractors;  $t(23) = .000$ ,  $p = 1.00$  for neuter distractors).

## References

- Alario, F. X., & Caramazza, A. (2002). The production of determiners: Evidence from French. *Cognition*, *82*, 179–223.
- Amso, D., & Johnson, S. P. (2005). Selection and inhibition in infancy: evidence from the spatial negative priming paradigm. *Cognition*, *95*, 27–36.
- Bašić, M. (2004). Nominal Subextractions and the Structure of NPs in Serbian and English. MA Thesis, University of Tromsø.
- Bialystok, E. (2010). Bilingualism. *Wiley interdisciplinary reviews: Cognitive science*, *1*, 559–572.
- Bialystok, E. (2011). Reshaping the mind: The benefits of bilingualism. *Canadian Journal of Experimental Psychology*, *65*, 229–235.
- Bialystok, E., Craik, F. I. M., Klein, R., & Viswanathan, M. (2004). Bilingualism, aging, and cognitive control: Evidence from the Simon task. *Psychology and Aging*, *19*, 290–303.
- Bialystok, E., Craik, F. I. M., & Luk, G. (2012). Bilingualism: Consequences for mind and brain. *Trends in Cognitive Sciences*, *16*, 240–250.
- Bloch, C., Kaiser, A., Kuenzli, E., Zappatore, D., Haller, S., Franceschini, R., Luedi, G., Radue, E. W., & Nitsch, C. (2009). The age of second language acquisition determines the variability in activation elicited by narration in three languages in Broca’s and Wernicke’s area. *Neuropsychologia*, *47*, 625–633.
- Blumenfeld, H. K., & Marian, V. (2013). Parallel language activation and cognitive control during spoken word recognition in bilinguals. *Journal of Cognitive Psychology*, *25* (5), 547–567.
- Bordag, D., & Pechmann, T. (2007). Factors influencing L2 gender processing. *Bilingualism: Language and Cognition*, *10*, 299–314.
- Bošković, Ž. (2006). Case and Agreement with Genitive of Quantification in Russian. In C. Boeckx (Eds.), *Agreement systems* (pp. 99–121). Amsterdam/Philadelphia: John Benjamins.
- Buckolz, E., Edgar, C., Kajaste, B., Lok, M., & Khan, M. (2012). Inhibited prime-trial distractor responses solely produce

- the visual spatial negative priming effect. *Attention, Perception, & Psychophysics*, 74, 1632–1643.
- Cacciari, C., & Cubelli, R. (2003). Special section on the neuropsychology of grammatical gender. *Cortex*, 39, 377–508.
- Caramazza, A., & Costa, A. (2000). The semantic interference effect in the picture-word interference paradigm: does the response set matter? *Cognition*, 75, B51–B64.
- Caramazza, A., & Miozzo, M. (1997). The relation between syntactic and phonological knowledge in lexical access: Evidence from the “tip-of-the-tongue” phenomenon. *Cognition*, 64, 309–343.
- Carstens, V. M. (2000). Concord in minimalist theory. *Linguistic Inquiry*, 31, 319–355.
- Chomsky, N. (1995). *The Minimalist Program*. Cambridge, MA: The MIT Press.
- Chondrogianni, V. (2008). The Acquisition of Determiners and Clitic Pronouns by Child and Adult L2 learners of Greek. Ph.D. dissertation, University of Cambridge, Cambridge.
- Corbett, G. G. (1988). Gender in Slavonic from the standpoint of a general typology of gender systems. *The Slavonic and East European Review*, 66, 1–20.
- Corbett, G. G. (1991). *Gender*. Cambridge, UK: Cambridge University Press.
- Costa, A., Caramazza, A., & Sebastián-Gallés, N. (2000). The cognate facilitation effect: Implications for models of lexical access. *Journal of Experimental Psychology: Learning, Memory, and Cognition*, 26, 1283–1296.
- Costa, A., Kovacic, D., Franck, J., & Caramazza, A. (2003). On the autonomy of the grammatical gender systems of the two languages of a bilingual. *Bilingualism: Language and Cognition*, 6 (3), 181–200.
- Costa, A., & Santesteban, M. (2004). Lexical access in bilingual speech production: Evidence from language switching in highly proficient bilinguals and L2 learners. *Journal of Memory and Language*, 50, 491–511.
- Costa, A., & Santesteban, M. (2006). The control of speech production by bilingual speakers: Introductory remarks. *Bilingualism: Language and Cognition*, 9, 115–117.
- Costa, A., Santesteban, M., & Ivanova, I. (2006). How do highly proficient bilinguals control their lexicalization process? Inhibitory and language-specific selection mechanisms are both functional. *Journal of Experimental Psychology: Learning, Memory, and Cognition*, 32 (5), 1057–1074.
- Costa, A., Sebastián-Gallés, N., Miozzo, M., & Caramazza, A. (1999). The Gender Congruity Effect: Evidence from Spanish and Catalan. *Language and Cognitive Processes*, 14, 381–391.
- Cubelli, R., Lotto, L., Paolieri, D., Girelli, M., & Job, R. (2005). Grammatical gender is selected in bare noun production: Evidence from the picture-word interference paradigm. *Journal of Memory and Language*, 53, 42–59.
- de Zubicaray, G. I., Miozzo, M., Johnson, K., Schiller, N. O., & McMahan, K. L. (2012). Independent distractor frequency and age-of-acquisition effects in picture-word interference: fMRI evidence for post lexical and lexical accounts according to distractor type. *Journal of Cognitive Neuroscience*, 24, 482–495.
- Dijkstra, T. (2005). Bilingual visual word recognition and lexical access. In J. F. Kroll & A. M. B. De Groot (Eds.), *Handbook of bilingualism: Psycholinguistic approaches* (pp. 179–201). New York: Oxford University Press.
- Epstein, S., Flynn, S., & Martohardjono, G. (1996). Second language acquisition: Theoretical and experimental issues in contemporary research. *Behavioral and Brain Sciences*, 19, 677–714.
- Fiszer, C. (2008). The Effect of Bilingualism on Cognition: Evidence from early and late bilinguals. Unpublished MA Thesis, EHESS, ENS, Paris 5 University.
- Foucart, A. (2008). Grammatical Gender Processing in French as a First and Second Language. Ph.D. dissertation, Edinburgh University, United Kingdom.
- Ganushchak, L. Y., Verdonschot, R. G., & Schiller, N. O. (2011). When leaf becomes neuter: event-related potential evidence for grammatical gender transfer in bilingualism. *Neuroreport*, 22, 106–110.
- Glaser, W. R., & Glaser, M. O. (1989). Context effects in Stroop-like word and picture processing. *Journal of Experimental Psychology: General*, 118 (1), 13–42.
- Green, D. W. (1998). Mental control of the bilingual lexico-semantic system. *Bilingualism: Language and Cognition*, 1, 67–81.
- Hernández, A., Hofmann, J., & Kotz, S. (2007). Age of acquisition modulates neural activity for both regular and irregular syntactic functions. *Neuroimage*, 36 (3), 912–923.
- Hernández, A., & Li, P. (2007). Age of acquisition: its neural and computational mechanisms. *Psychological Bulletin*, 133, 638–650.
- Holton, D., Mackridge, P., & Philippaki-Warbuton, I. (2004). *Greek: An essential grammar of the modern language*. London: Routledge.
- Janssen, N., & Caramazza, A. (2003). The selection of closed-class words in noun phrase production: The case of Dutch determiners. *Journal of Memory and Language*, 48, 635–652.
- Janssen, N., Schirm, W., Mahon, B. Z., & Caramazza, A. (2008). The semantic interference effect in the picture-word interference paradigm: Evidence for the response selection hypothesis. *Journal of Experimental Psychology: Learning, Memory, and Cognition*, 34, 24–256.
- Kroff, J. V., Coffman, D., Dussias, J., Gerfen, C., Gullifer, J., & Guzzardo-Tamargo, R. (2010). Differential processing of grammatical gender in a sentential context: eye-tracking evidence from Spanish monolinguals and Spanish-English bilinguals. Poster presentation at the 23rd Annual CUNY Conference on Human Sentence Processing, New York.
- La Heij, W., Mak, P., Sander, J., & Willeboordse, E. (1998). The gender-congruency effect in picture-word tasks. *Psychological Research*, 61, 209–219.
- Lemhöfer, K., Spalek, K., & Schriefers, H. (2008). Cross-language effects of grammatical gender in bilingual word recognition and production. *Journal of Memory and Language*, 59, 312–330.
- Levelt, W. J. M., Roelofs, A., & Meyer, A. S. (1999). A theory of lexical access in speech production. *Behavioral and Brain Science*, 22, 1–75.
- Luk, G., DeSa, E., & Bialystok, E. (2011). Is there a relation between onset age of bilingualism and enhancement of cognitive control? *Bilingualism: Language and Cognition*, 14, 488–495.

- Lupker, S. J. (1979). The semantic nature of response competition in the picture–word interference task. *Memory & Cognition*, 7, 485–495.
- Macizo, P. & Bajo, M. T. (2006). Reading for Repetition and Reading for Translation: Do they involve the same process? *Cognition*, 99, 1–34.
- Marian, V. & Spivey, M. (2003). Comparing bilingual and monolingual processing of competing lexical items. *Applied Psycholinguistics*, 24, 173–193.
- Marx, E. (1999). Gender processing in speech production: Evidence from German speech errors. *Journal of Psycholinguistic Research*, 28, 601–621.
- Mastropavlou, M. & Tsimpli, I. M. (2011). The role of suffixes in grammatical gender assignment in Modern Greek: A psycholinguistic study. *Journal of Greek Linguistics*, 11, 27–55.
- Meisel, J. M. (2009). Second language acquisition in early childhood. *Zeitschrift Für Sprachwissenschaft*, 28, 5–34.
- Meyer, A. S. (1996). Lexical access in phrase and sentence production: Results from picture–word interference experiments. *Journal of Memory and Language*, 30, 69–89.
- Miozzo, M. & Caramazza, A. (1999). The selection of determiners in noun phrase production. *Journal of Experimental Psychology: Learning, Memory, and Cognition*, 28, 555–563.
- Miozzo, M., Costa, A., & Caramazza, A. (2002). The absence of a gender congruency effect in romance languages: A matter of stimulus onset asynchrony? *Journal of Experimental Psychology: Learning, Memory, and Cognition*, 28, 388–391.
- Morales, L., Paolieri, D., & Bajo, T. (2011). Grammatical gender inhibition in bilinguals. *Frontiers in Psychology*, 2. doi:10.3389/fpsyg.2011.00284.
- Neill, W. T., & Westberry, R. L. (1987). Selective attention and the suppression of cognitive noise. *Journal of Experimental Psychology: Learning, Memory, & Cognition*, 13, 327–334.
- Neumann, E., & DeSchepper, B. G. (1992). An inhibition-based fan effect: Evidence for an active suppression mechanism in selective attention. *Canadian Journal of Psychology*, 46 (1), 1–40.
- Paolieri, D., Cubelli, R., Macizo, P., Bajo, M. T., Lotto, L., & Job, R. (2010). Grammatical gender processing in Italian and Spanish bilinguals. *The Quarterly Journal of Experimental Psychology*, 63, 1631–1645.
- Progovac, L. (1998). Determiner Phrase in a language without determiners. *Journal of Linguistics*, 34, 165–179.
- Ralli, A. (2002). The role of morphology in gender determination: Evidence from Modern Greek. *Linguistics*, 40, 519–551.
- Ratcliff, R. (1993). Methods for dealing with reaction time outliers. *Psychological Bulletin*, 114, 510–532.
- Raven, J. (1962). *Coloured progressive matrices*. New York: The Psychological Corporation.
- Roelofs, A. (1998). Lemma selection without inhibition of languages in bilingual speakers. *Bilingualism: Language and Cognition*, 1, 94–95.
- Salamoura, A., & Williams, J. N. (2007). The representation of grammatical gender in the bilingual lexicon: Evidence from Greek and German. *Bilingualism: Language and Cognition*, 10, 257–275.
- Schiller, N. O., & Caramazza, A. (2003). Mechanisms of determiner selection: Evidence from noun phrase production in German and Dutch. *Journal of Memory and Language*, 48, 169–194.
- Schneider, W., Eschman, A., & Zuccolotto, A. (2002). *E-Prime user's guide*. Psychology Software Tools Inc, Pittsburgh.
- Schriefers, H. (1993). Syntactic processes in the production of noun phrases. *Journal of Experimental Psychology: Learning, Memory, and Cognition*, 19 (4), 841–850.
- Schriefers, H., Jescheniak, J. D., & Hantsch, A. (2002). Determiner selection in noun phrase production. *Journal of Experimental Psychology: Learning, Memory, and Cognition*, 28, 941–950.
- Schriefers, H. & Teruel, E. (2000). Grammatical gender in noun production: The gender interference effect in German. *Journal of Experimental Psychology: Learning, Memory, and Cognition*, 26, 1368–1377.
- Sebastián-Gallés, N., Rodríguez-Fornells, A., Diego-Balaguer, R., & Diaz, B. (2006). First- and second-language phonological representations in the mental lexicon. *Journal of Cognitive Neuroscience*, 18, 1277–1291.
- Seva, N., Kempe, V., Brooks, P. J., Mironova, N., Pershukova, A. & Fedorova, O. (2007). Cross-linguistic evidence for the diminutive advantage: Gender agreement in Russian and Serbian children. *Journal of Child Language*, 34, 111–131.
- Snodgrass, J. G., & Vanderwart, M. (1980). A standardized set of 260 pictures: Norms for name agreement, image agreement, familiarity, and visual complexity. *Journal of Experimental Psychology: Human Learning & Memory*, 6, 174–215.
- Starreveld, P. A., & La Heij, W. (1996). Time-course analysis of semantic and orthographic context effects in picture naming. *Journal of Experimental Psychology: Learning, Memory, & Cognition*, 22, 869–918.
- Tao, L., Marzecová, A., Taft, M., Asanowicz, D., & Wodniecka, Z. (2011). The efficiency of attentional networks in early and late bilinguals: The role of age of acquisition. *Frontiers in Psychology*, 2, 123.
- Treccani, B., Argyri, E., Sorace, A., & Della Sala, S. (2009). Spatial negative priming in bilingualism. *Psychonomic Bulletin & Review*, 16, 320–327.
- Trenkic, D. (2004). Definiteness in Serbian/Croatian/Bosnian and some implications for the general structure of the nominal phrase. *Lingua*, 114, 1401–1427.
- Tsimpli, I. M., & Hulk, A. (2013). Grammatical gender and the notion of default: insights from language acquisition. *Lingua*, 137, 128–144.
- Tsimpli, I. M., & Mastropavlou, M. (2007). Feature Interpretability in L2 Acquisition and SLI: Greek Clitics and Determiners. In H. Goodluck, J. Liceras & H. Zobl (eds.), *The Role of Formal Features in Second Language Acquisition*, pp. 143–183. London: Routledge.
- van Turenout, M., Hagoort, P., & Brown, C. (1998) Brain activity during speaking: from syntax to phonology in 40 milliseconds. *Science*, 280, 572–574.



- Ullman, M. T. (2001). The neural basis of lexicon and grammar in first and second language: The declarative/procedural model. *Bilingualism: Language and Cognition*, 4, 105–122.
- Ullman, M. T. (2005) A cognitive neuroscience perspective on second language acquisition: The declarative/procedural model. In C. Sanz (eds.), *Mind and context in adult second language acquisition: Methods, theory and practice*, pp. 141–178. Washington, DC: Georgetown University Press.
- Ullman, M. T., Corkin, S., Coppola, M., Hickok, G., Growdon, J. H., Koroshetz, W. J., & Pinker, S. (1997). A neural dissociation within language: Evidence that the mental dictionary is part of declarative memory, and that grammatical rules are processed by the procedural system. *Journal of Cognitive Neuroscience*, 9, 266–276.
- Varlokosta, S. (2011). The role of morphology in grammatical gender assignment: A psycholinguistic study in Greek. In A. Galani, G. Hicks & G. Tsoulas (Eds.), *Morphology and its Interfaces* (pp. 49–76). Amsterdam: John Benjamins.
- Zlatić, L. (1997). *The structure of the Serbian Noun Phrase*. Ph.D. dissertation. University of Texas at Austin.