

CORRESPONDENCE

The Editor,

Journal of Glaciology

SIR,

The origin of vertical c-axis ice on Peters Lake, Alaska

In our recent paper in the *Journal of Glaciology* (Vol. 4, No. 36, p. 689–708), we made a rather hasty speculation about the origin of vertical *c*-axis ice on Peters Lake, Alaska. The speculation offered does not explain every case but suggests only one possibility. We should like to offer another explanation.

Knight (1962) has observed that wind is a primary factor in the formation of ice having *c*-axes which are predominantly vertical or predominantly horizontal and the break-up of the initial ice skim which results from wind action is also important.

Arakawa and Higuchi (1952) and Arakawa (1954, 1955) have determined the physical conditions under which disc crystals are produced and continue to grow in stellar form, as a result of a series of detailed studies on freezing water. A disc crystal floating on the water surface has a vertical *c*-axis and can only be produced when the water temperature is very close to the ice point.

Since supercooling, heat conduction and convection should be considered important in the freezing process, it is difficult to explain how an initial ice skim with vertical *c*-axes can be produced over an extensive lake area under natural conditions. In an ordinary case, the distribution of the *c*-axes should be random. The initial ice skim would be formed by various types of ice crystals, i.e. needle, feather, and disc or stellar forms (Arakawa and Higuchi, 1952). The mode of formation is illustrated in Figure 1.

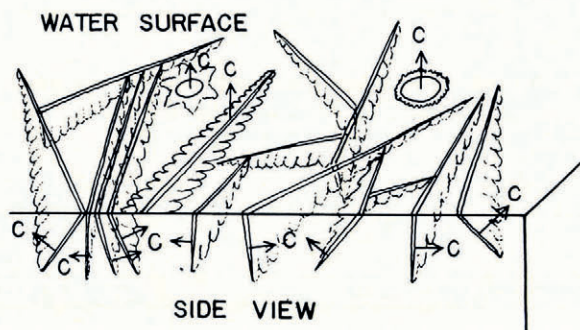

Fig. 1. The mode of formation of the initial ice skim

If the supercooled water layer is thick, barb-like vanes with *c*-axes normal to the plate of the vane will grow rapidly in the supercooled water from the needle crystal on the surface, because of the rapid growth of basal planes of ice crystals (Lyons and Stoiber, 1962). Even if crystals of disc or stellar form are produced among the needle crystals floating on the water surface, their growth will be restricted by the rapid growth of the needle and barb-like vane crystals on the water surface and in the water. This might be called the first step of orientation selection by grain growth, which is characterized by a predominance of horizontal *c*-axis crystals.

Wind breaks the initial ice skim, so that each of the barb-like vanes is freed and may then float on the water surface. Since the *c*-axis orientation of each feather-like crystal is normal to its vane plate, the newly formed ice skim has vertical *c*-axes. Wind would also push this newly formed ice skim towards the edge, so that the ice in this part of the lake would have vertical *c*-axes. The orientation of the *c*-axes in the ice skim would greatly affect the *c*-axis orientation of the ice which subsequently grows in the water.

The mode of random distribution of *c*-axis orientation is necessary for a clearer understanding of the histograms of *c*-axis orientation given in our previous paper (Muguruma and Kikuchi, 1963). Random distribution of *c*-axis orientation means in a statistical sense that *c*-axis orientation is distributed uniformly on a hemispherical surface. Then it is expressed as the ratio of the area of the hemisphere to the

area of a zone which is cut at an arbitrary latitude as shown in Figure 2. The latter area can be calculated by the following equation:

$$S = 2\pi R^2 \int_{\alpha_2}^{\alpha_1} \cos \alpha \, d\alpha,$$

where S is the area of the zone, and α_1 and α_2 are the latitudes of the upper and lower ends of the zone. Taking $\alpha_1 - \alpha_2 = 10^\circ$, the mode of random distribution of the c -axis orientation is shown in Figure 3. This figure shows that, even if 50 per cent of the ice grains have a c -axis orientation of $\theta = 60 \sim 90^\circ$, the

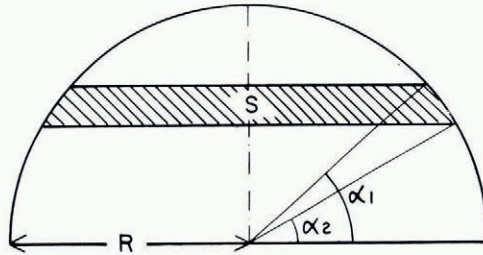

Fig. 2. The hemispherical surface with a zone cut at an arbitrary latitude, used for calculation of a random distribution of c -axis orientation

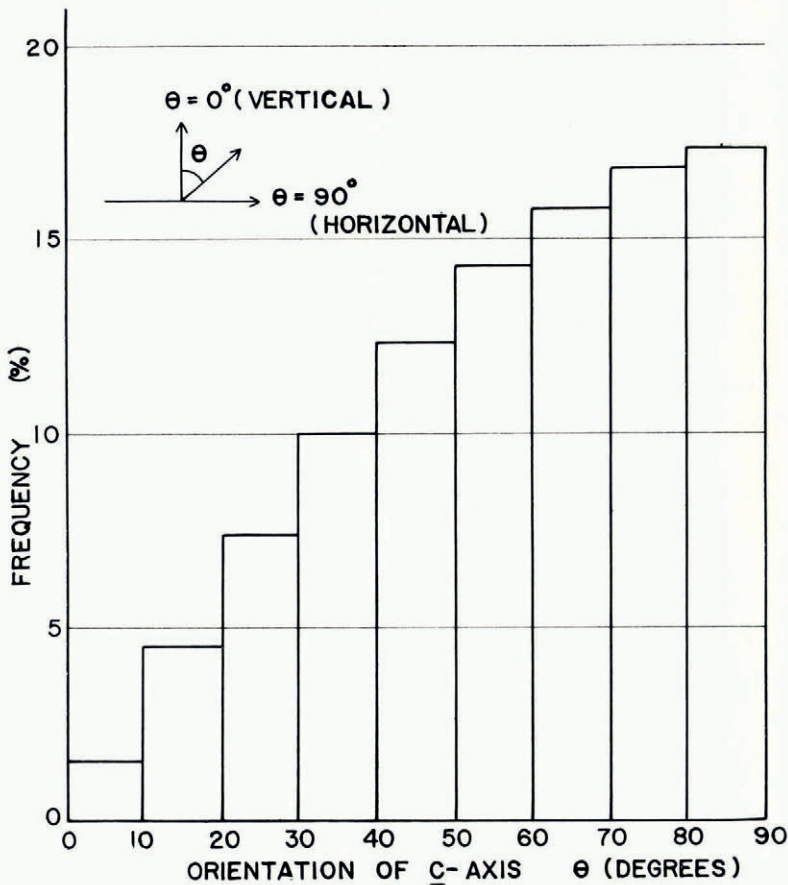

Fig. 3. Histograms illustrating random distribution of c -axis orientation

ice cannot be said to have predominantly horizontal c -axes. When the distribution of the c -axis orientation is considered, the mode of random distribution of the c -axis should always be kept in mind. Statistical treatment is also necessary for detailed analysis of the data of c -axis distribution. In this sense, the data obtained by observing Tyndall figures at Peters Lake support the conclusion that the ice has a predominantly horizontal c -axis orientation.

We are grateful to Drs. K. Arakawa and C. A. Knight for their valuable suggestions and discussions.

Department of Physics,
Faculty of Science,
Hokkaido University,
Sapporo, Japan
3 February 1964

JIRO MUGURUMA
KATSUHIRO KIKUCHI

REFERENCES

- Arakawa, K. 1954. Studies on the freezing of water (2). *Journal of the Faculty of Science, Hokkaido University*, Ser. 2, Vol. 4, No. 5, p. 311–39.
- Arakawa, K. 1955. The growth of ice crystals in water. *Journal of Glaciology*, Vol. 2, No. 17, p. 463–67.
- Arakawa, K., and Higuchi, K. 1952. Studies on the freezing of water (1). *Journal of the Faculty of Science, Hokkaido University*, Ser. 2, Vol. 4, No. 3, p. 201–08.
- Knight, C. A. 1962. Studies of Arctic lake ice. *Journal of Glaciology*, Vol. 4, No. 33, p. 319–35.
- Lyons, J. B., and Stoiber, R. E. 1962. Orientation fabrics in lake ice. *Journal of Glaciology*, Vol. 4, No. 33, p. 367–70.
- Muguruma, J., and Kikuchi, K. 1963. Lake ice investigation at Peters Lake, Alaska. *Journal of Glaciology*, Vol. 4, No. 36, p. 689–708.

SIR,

Discussion on Kamb and LaChapelle's paper "Direct observation of the mechanism of glacier sliding over bedrock"

In their paper, Kamb and LaChapelle (1964) conclude that the observed velocity of cubes 1 cm. on a side pulled through ice disagrees with the prediction of figure 2 in my original sliding paper (Weertman, 1957). Figure 2 indicated that a 1 cm.³ cube pushed with a force of 16 kg. will move through ice at the same velocity regardless of whether the mechanism of motion is provided entirely by pressure melting or by creep-rate enhancement. The results of Kamb and LaChapelle show that at a force (17.6 kg.) which is close to 16 kg., the velocity is faster if pressure melting is the operative mechanism. Moreover, Kamb and LaChapelle point out that in their experiment, the effective stress to be used in the creep enhancement mechanism must be increased over the stress I used by factor of 2. This modification increases the predicted velocity of the creep-rate enhancement mechanism by a factor of 2^n , where n is of the order of 3 to 4. This increase makes the disagreement between theory and experiment even greater.

In figure 2 of my original paper Glen's value of $n = 4.2$ was used in the calculation. It is more fashionable now to use a value near 3. If Glen's other value of $n = 3.2$ is used in the calculations, the velocity predicted by figure 2 for the creep enhancement mechanism is decreased by a factor of 8. This factor of 8 has to be multiplied by $2^n = 2^{3.2} = 9.2$ in order to make a comparison with the experiments of Kamb and LaChapelle. Thus the velocity due to the creep-rate enhancement mechanism is a factor of $9.2/8 = 1.15$ larger than that given by figure 2. It would appear that theory and experiment still disagree.

Although Kamb and LaChapelle modified the calculation of the creep-rate enhancement velocity by the factor 2^n , they neglected to make a similar modification in the pressure-melting velocity calculation. They pointed out that the hydrostatic pressure difference on either side on an obstacle should be increased by a factor of 3 over the value I used, but they did not correct figure 2 for the resultant factor of 3 increase in velocity. They also neglected to take into account the fact that the thermal diffusion coefficient used in my calculations for figure 2 was a factor of 2.4 smaller than the thermal diffusion coefficient of dunite and plexiglass used in their experiments. Therefore, the calculated pressure melting sliding velocity of figure 2 should have been increased a factor of $2.4 \times 3 = 7.2$. The sliding velocity due to the pressure-melting mechanism thus should be a factor $7.2/1.15 = 6.2$ larger than that of the creep-rate enhancement mechanism. These modifications of the calculations result in a predicted pressure-melting velocity of 3 cm./day, as compared to that observed, at the melting point, of 3.4 cm./day for a dunite cube and 1.6 cm./day for a plexiglass cube. The theoretical value for the velocity