

FAMILIAL TWINNING: A CASE FOR SUPERFETATION IN MAN*

S.A. RHINE**, WALTER E. NANCE

Department of Medical Genetics, Indiana University School of Medicine, Indianapolis, Indiana, USA

A family is described in which the tendency to bear twins is expressed in the offspring of males as well as females. All of the twins born in this family show marked discordance in birth weight and gestational age. In 5 of the 6 pairs, one twin was normal while the other was either a macerated fetal mass, stillborn, or died of prematurity in the neonatal period. The one pair in which both twins did survive is known to be DZ and showed a difference in maturity and a 21% discrepancy in birth weight. Thus, twinning in this family appears to be transmitted as an autosomal dominant trait which is expressed in the offspring of both female and male carriers. Of all possible genetic mechanisms which could explain this familial aggregation of markedly discordant twins, superfetation seems most consistent with the genetic transmission and expression of the trait in the offspring of both males and females. The most plausible explanation of the pedigree is that a dominant gene is segregating in the family which is expressed in the fetal placenta where it acts to reverse the normal hormonal inhibition of ovulation. Since both the father and the mother contribute to the genotype of the placenta, superfetation could occur among offspring of both males and females who carry the gene.

Although MZ twinning in man appears to be a sporadic event, it is generally agreed that hereditary factors in the mother may predispose to DZ twinning. The evidence usually cited to substantiate this claim includes the well-known variation in the frequency of DZ twinning in different racial groups; the increased frequency of twinning among women who have previously borne one DZ twin set; the difference in the incidence of DZ twinning among the progeny of reciprocal interracial marriages; and the characteristic changes in the DZ twinning rate that occur with increasing maternal age (Bulmer 1970). Weinberg (1902, 1909) proposed that DZ twinning is inherited as a sex-limited trait, probably a recessive, which is expressed in the female ovary and results in polyovulation. This hypothesis was supported by the studies of White and Wyshak (1964) and Wyshak and White (1965), who found an increased incidence of DZ twins among the offspring of female DZ twins and their female sibs but not among the offspring of male DZ twins or their male sibs. Reports of a paternal influence on DZ twinning (Davenport 1928, Greulich 1934) have been attributed by some authors to biased reporting of the family history (Bulmer 1960).

We have recently observed an unusual family in which the tendency to twinning appears to be transmitted as a dominant trait, expressed in the offspring of both female and male members of the family. The findings suggest that the paternal genotype does, in some instances, influence the occurrence of DZ twinning.

* This is publication number 74-25 from the Department of Medical Genetics, and was supported in part by the Indiana University Human Genetics Center, POI HD 10291-01 and a grant from the John A. Hartford Foundation, Inc.

** Trainee USPHS Training Grant DE 119.

CODEN: AGMGAK 25 66 (1976) — ISSN: 0001-5660
Acta Genet. Med. Gemellol. (Roma) 25: 66-69

The proband was a healthy, full-term, 5-pound male infant who was the surviving member of a twin set (Figure). The cotwin was a 1-pound stillborn male fetus, with a developmental age of approximately 5 months, who was believed to have died shortly before delivery. There were two separate placentae, but no other information regarding zygosity was obtained.

The pedigree revealed a total of 6 sets of twins in 4 consecutive generations. In all 6 pairs one twin was normal at birth while the second was a macerated fetus, stillborn, or premature. The maternal great-grandmother of the proband was a surviving twin whose cotwin had been stillborn. The maternal grandfather was a normal infant while his cotwin was a premature male, weighing 3 pounds, who lived only 3 weeks. A maternal uncle was delivered normally while his cotwin, a macerated fetus, was delivered 9 days later. This uncle has fathered the only surviving twin set, a DZ female pair who differed in birth weight by 21%; the zygosity of these twin girls was confirmed by genotyping which revealed differences in 2 of 10 polymorphic loci. A maternal aunt was also a normal twin whose cotwin was a macerated fetus delivered 4 days later. As shown in the Figure, the tendency to twinning in this family appears to be transmitted as an autosomal dominant trait, and is expressed among the offspring of at least two females and two males who carry the gene.

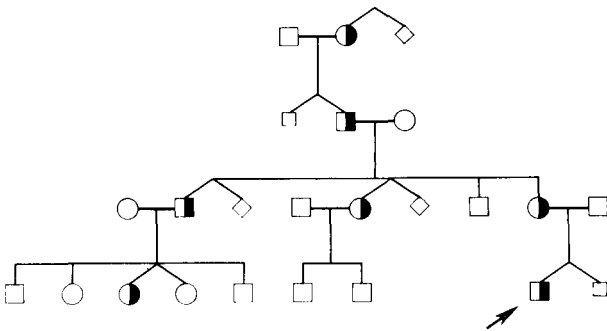

Figure. Pedigree of family showing dominant transmission of twinning in four generations. Half-shaded figures designate individuals assumed to carry a dominant gene permitting superfetation.

We have considered several mechanisms which could explain the remarkable discordance in development at birth, observed in every twin pair in this family. Polyovulation followed by the delayed implantation of one blastocyst is a possible explanation. Vandeplassche (1969) has provided convincing evidence that such a mechanism can account for split parturition in the pig and has speculated that the same phenomenon may occur in other mammals including man. Although multiple ovulation with delayed implantation can readily account for developmental discordance in DZ twins, in our specific case any hereditary mechanism which involves polyovulation cannot explain the occurrence of twins among the offspring of both female *and* male family members. Retarded intra-uterine growth of one twin is also an unacceptable explanation for it, too, depends upon hereditary polyovulation to account for familial twinning. The same objection excludes abnormal meiotic events in the female or spermatozoan influences in the male as possible explanations for the twinning in the present family.

As an alternative hypothesis, we suggest that the twinning in this family results from segregation of an abnormal dominant gene which is expressed in the placenta, where it acts to permit superfetation by reversing the normal inhibition of ovulation during pregnancy. The fertilization and subsequent implantation of an ovum released during pregnancy would lead to the occurrence of two fetuses of different gestational ages within the same uterus. Since both parents contribute to the genotype of the placenta, this hypothesis would explain how the tendency to twinning in the family described here can be expressed among the offspring of both males and females who carry the gene. The hypothesis also accounts for the marked discrepancies in birth weight and development that have been documented in all six twin pairs.

Since antiquity, examples of alleged superfetation have been reported in many mammalian species including man (Studdiford 1936, O'Neill 1974). In human cases the separate deliveries of healthy

full-term infants from the same mother more than 60 days apart have been proposed as evidence for superfetation (Druker et al. 1960). Some of these cases (Green et al. 1961) occurred in association with uterus didelphys and resulted in the separate delivery of normal infants from each uterus more than a month apart. The contemporaneous birth or abortion of twin infants of different weight and developmental age (Studdiford 1936) has also been suggested as evidence for superfetation. Scrimgeour and Baker (1974) have recently published a remarkable photograph of spontaneously aborted twins who were markedly discordant in developmental age. There was no evidence of arrested development in the small fetus, and the authors concluded that the twins differed by at least 20 days in developmental age and most likely arose by superfetation. Thus, it seems clear that a second ovulation can sometimes occur during an otherwise normal pregnancy. Some cases of dichorial fetus papyracei (Camiel 1967) may also arise in a similar manner.

Under normal conditions, ovulation results from the simultaneous stimulation of the ovary by two hypophyseal gonadotropins, follicle-stimulating hormone (FSH) and luteinizing hormone (LH) (Segal 1974). After ovulation occurs, estrogens and progesterone from the corpus luteum exert a negative feedback, probably mediated through the hypothalamus, which inhibits FSH and LH secretion. If conception takes place, the developing embryo begins secreting human chorionic gonadotropin (HCG), perhaps even before implantation (Haour and Sacena 1974), which maintains the corpus luteum and therefore the uterotrophic and feedback effects of progesterone and estrogens. However, HCG has also been found to exhibit both FSH-like follicle-stimulating activity (Albert 1969) and LH-like ovulation induction properties (Reid et al. 1972). Consequently, it is conceivable that a genetically determined qualitative or quantitative abnormality affecting placental HCG production might stimulate a second ovulation, thereby providing an opportunity for superfetation to occur.

Alternatively, a genetic abnormality affecting the quantity of placental estrogens might also predispose to superfetation. As pregnancy progresses, the uterotrophic and inhibitory effects of the corpus luteum hormones are gradually subsided by progesterone and estrogens of placental origin. The *de novo* synthesis of estrogen precursors in the placenta is minimal (Reid et al. 1972). Rather, sulfated estrogen precursors such as dehydroepiandrosterone sulfate (DHEAS) and 16-hydroxy-DHEAS, which are derived primarily from the fetal adrenal cortex, are utilized for estrogen synthesis by the placenta.

These precursors are deconjugated by a specific placental sulfatase as the initial step in the placental biosynthesis of estrogens. Placental sulfatase deficiencies have been reported (France et al. 1973) in pregnancies culminating in the delivery of healthy infants even though the placental estrogens and consequently the circulating maternal estrogens were reduced to 10-15% of normal levels. It is possible that a decrease in circulating maternal estrogens resulting from a placental sulfatase deficiency could lead to a reversal of the normal inhibition of FSH during pregnancy, thereby allowing ovulation to occur under the combined influence of FSH and placental HCG. In this regard, it is of interest that a family with known placental sulfatase deficiency included a DZ twin set consisting of a normal male and a stillborn female (France 1974).

If ovulation does occur during pregnancy by any of the above mechanisms, superfetation would take place only if the ovum is fertilized. Therefore, a carrier of the gene, such as the proband's mother in our pedigree, will not invariably be a twin or the surviving member of a twin set. The hypothesis we have proposed could readily be tested in families of the type we have described by monitoring maternal hormone levels during pregnancy or by appropriate biochemical analyses of placental tissue. If superfetation occurs with appreciable frequency in man, it could have important implications for genetic studies of twins. In particular, it would artificially inflate both the total variance and the within-pair variance of DZ twins and would quite likely bias any evidence for a genetic effect that the twin sample provides. The genetic mechanism for superfetation that we have suggested is one which applies equally to both male and female carriers of the mutant gene. Consequently, it may well provide a physiologic explanation for the so-called "father factor" that has been invoked in previous studies of the genetic control of DZ twinning to explain the occurrence of a family history of twinning in the paternal as well as the maternal lineage.

REFERENCES

- Albert A. 1969. Follicle-stimulating activity of HCG. *J. Clin. Endocrinol. Metab.*, 29: 1502-09.
- Bulmer M. G. 1960. The familial incidence of twinning. *Ann. Hum. Genet.*, 24: 1-3.
- Bulmer M.G. 1970. *The Biology of Twinning in Man*. Oxford: Clarendon Press.
- Camiel M.R. 1967. Fetus papyraceus with intra-uterine sibling death. *JAMA*, 202: 247.
- Davenport C.B. 1928. Is the inheritance of twinning tendency from fathers side? In H. Nachtsheim (ed.): *Verhandlungen des 5 Internationalen Kongresses für Vererbungswissenschaft*. Leipzig: Bornträger.
- Druker P., Finkel J., Savel L.E. 1960. Sixty-five day interval between the birth of twins. *Am. J. Obstet. Gynecol.*, 80: 761-63.
- France J.T., Seddon R.J., Liggins G.C. 1973. A study of a pregnancy with low estrogen production due to placental sulfatase deficiency. *J. Clin. Endocrinol. Metab.*, 36: 1-9.
- France J.T. 1974. Personal communication.
- Green Q.L., Schanck G.P., Smith J.R. 1961. Normal living twins in uterus didelphys with 38 day interval between deliveries. *Am. J. Obstet. Gynecol.*, 82: 340-42.
- Greulich W.W. 1934. Heredity in human twinning. *Am. J. Phys. Antropol.*, 19: 391-431.
- Haour F., Sacena B.B. 1974. Detection of gonadotropin in rabbit blastocyst before implantation. *Science*, 185: 444-45.
- O'Neill Y.V. 1974. Michele Savonarola and the fera or blighted twin phenomenon. *Medical History*, 18: 222-39.
- Reid D.E., Ryan K.J., Benirschke K. 1972. *Principles and management of human reproduction*. Philadelphia: W.B. Saunders Company.
- Scrimgeour J.B., Baker T.G. 1974. A possible case of superfetation in man. *J. Reprod. Fert.*, 36: 69-73.
- Segal S.J. 1974. The physiology of human reproduction. *Sci. Am.*, 231: 52-59.
- Studdiford W.E. 1936. Is superfetation possible in the human being? *Am. J. Obstet. Gynecol.*, 31: 845-55.
- Vandeplassche M. 1969. The physiological explanation of split parturition in the pig and other mammalian species. *Ann. Endocrinol.*, 30: 328-41.
- Weinberg W. 1902. Beiträge zur Physiologie und Pathologie der Mehrlingsgeburten beim Menschen. *Pflügers, Arch. ges. Physiol.*, 88: 346-430.
- Weinberg W. 1909. Zur Bedeutung der Mehrlingsgeburten für die Frage der Bestimmung des Geschlechts. *Arch. f. Rassen- u. Gesellsch-Biol.*, 6: 28-32.
- White C., Wyshak G. 1964. Inheritance in human dizygotic twinning. *New Engl. J. Med.*, 271: 1003-05.
- Wyshak G., White C. 1965. Genealogical study of human twinning. *Am. J. Public Health.*, 55: 1586-93.