

Study & Master

# Technology



**FREE**

downloadable  
Teacher's Guide

Teacher's Guide

Grade

**7**

Ria de Jager • Lin Bassett • Neel Ramdutt  
Lynn Pocock • Barbara Munsami

*Study & Master*

# Technology

## Grade 7 Teacher's Guide

Ria de Jager • Lin Bassett • Neel Ramdutt  
Lynn Pocock • Barbara Munsami



**CAMBRIDGE**  
UNIVERSITY PRESS

# CAMBRIDGE UNIVERSITY PRESS

University Printing House, Cambridge CB2 8BS, United Kingdom

One Liberty Plaza, 20th Floor, New York, NY 10006, USA

477 Williamstown Road, Port Melbourne, VIC 3207, Australia

314–321, 3rd Floor, Plot 3, Splendor Forum, Jasola District Centre, New Delhi – 110025, India

79 Anson Road, #06–04/06, Singapore 079906

The Water Club, Beach Road, Granger Bay, Cape Town 8005, South Africa

Cambridge University Press is part of the University of Cambridge.

It furthers the University's mission by disseminating knowledge in the pursuit of education, learning and research at the highest international levels of excellence.

[www.cambridge.org](http://www.cambridge.org)

Information on this title: [www.cambridge.org/9781107256774](http://www.cambridge.org/9781107256774)

© Cambridge University Press 2013

This publication is in copyright. Subject to statutory exception and to the provisions of relevant collective licensing agreements, no reproduction of any part may take place without the written permission of Cambridge University Press.

First published 2013

Reprinted 2020

Typesetter: Lee-ann Harris of Purple Design

ISBN 978-1-107-25677-4

Editor: Timothy Nicol

Proofreader: Heather Thorne

Typesetter: Lizette Stuart

Illustrators: Phillip du Plessis, Ruth Frances, Will Alves (Sunset Beach Studio), Yancke van Tonder

Cover image: *Equidae burcheli*, commonly known as a baby zebra, © Bernie Olbrich/AfriPics

.....  
Cambridge University Press has no responsibility for the persistence or accuracy of URLs for external or third-party internet websites referred to in this publication, and does not guarantee that any content on such websites is, or will remain, accurate or appropriate. Information regarding prices, travel timetables and other factual information given in this work are correct at the time of first printing but Cambridge University Press does not guarantee the accuracy of such information thereafter.  
.....

## NOTICE TO TEACHERS

The photocopy masters in this publication may be photocopied or distributed [electronically] free of charge for classroom use within the school or institution which purchases the publication. Worksheets and copies of them remain in the copyright of Cambridge University Press and such copies may not be distributed or used in any way outside the purchasing institution.  
.....

## Acknowledgements

The publisher is grateful to the following individuals, institutions and organisations for permission to reproduce photographs:

**Agefotostock:** E16; **Bigstock:** D42 (bottom left, right), D43 (left, middle), D44 (top left, top right), D74 (top right, bottom left, bottom right), D110, E8, E12 (top centre, top right, bottom left, bottom centre), E 14 (top left and centre, bottom left), E15; **iStockphoto:** D42 (top left), D74 (bottom left, bottom centre), D90, D91, D92, D98, E12 (top right), E13 (middle left and right), E14 (top right), E16 (bottom) **Shutterstock:** D43 (right)  
.....

If you want to know more about this book or any other Cambridge University Press publication, phone us at +27 21 4127800, fax us at +27 21 419-8418 or send an e-mail to [capetown@cambridge.org](mailto:capetown@cambridge.org)

## **Contents**

<b>Expanded contents pages</b>	<b>IV</b>
<b>Section A: Introduction</b>	<b>A1</b>
<b>Section B: Planning</b>	<b>B1</b>
<b>Section C: Assessment</b>	<b>C1</b>
<b>Section D: Teaching Guidelines</b>	<b>D1</b>
<b>Section E: Photocopiable resources</b>	<b>E1</b>
<b>Section F: Documents</b>	<b>F1</b>
<b>Guidelines to strengthen CAPS</b>	<b>F3</b>



Section A: Introduction										A1	
Section B: Planning										B1	
Section C: Assessment										C1	
Section D: Teaching Guidelines										D1	
Term	Strand	Module	Unit	Time allocation (weeks & hours)	Lesson	Activities	CAPS content, concepts and skills	Assessment tasks	Resources	LB page	TG page
1	Design process skills	1: Design process skills	1.1: Introduction	1 week (1 hour)	Lesson 1	Activity 1 Activity 2 Activity 3	Definition Scope: Who does technology in the 'world of work'?	Survey Investigate/ Worksheet Recording	Examples of technology at work	6/7 7 8	D5
			1.2: Design considerations	1 week (1 hour)	Lesson 2	Activity 4 Activity 5 Activity 6 Activity 7 Activity 8 Activity 9	Investigate: finding, using and acknowledging information. Design: design brief, specifications, constraints, initial idea sketches, choosing the best design, selecting materials. Make: drawing plans, develop the manufacturing sequence, make the item/model Evaluate: learners evaluate both their design stages and their final product. Communicate: learners present their solutions, learners compile all notes and drawings into a project report in their class-work books. Fit-for-purpose	Learner evaluation of design brief	Examples of bookmarks Project portfolio	9/10 11 12 12 13 13	D6

<b>Term</b>	<b>Strand</b>	<b>Module</b>	<b>Unit</b>	<b>Time allocation (weeks &amp; hours)</b>	<b>Lesson</b>	<b>Activities</b>	<b>CAPS content, concepts and skills</b>	<b>Assessment tasks</b>	<b>Resources</b>	<b>LB page</b>	<b>TG page</b>
1	Communication skills	2: Communication skills	2.1 Introduction to graphical communication	1 week (2 hours)	Lesson 3	Activity 10 Activity 11a Activity 11b Activity 11c Activity 11d Activity 11e Activity 11f	Purpose of graphics: develop ideas and communicate ideas.  Conventions: outlines (thick/dark), construction lines (thin/feint), hidden detail (dashed) scale, dimensioning.	Class survey Drawings	Examples of graphical communication Paper to practice the conventions of line drawing	14/15 18 18 18 20 21 21	D14
					Lesson 4	Activity 12 Activity 13	Sketching: freehand sketching.  Working drawings: 2-dimensional drawing of one face of an object using conventions.	Drawings Bookmarks drawings	Paper and drawing equipment	22/23 25	D25 D29
			2.2: Graphic techniques	1 week (2 hours)	Lesson 5	Activity 14a Activity 14b	3-D oblique: front view with depth at 45°, oblique projection used to assist with interpretation, and with drawing single VP perspective.	Drawings of oblique projection	Squared (quadrant) paper to practice 3-D oblique drawing Pencil	27/29 29	D30
					Lesson 6	Activity 15	3-D artistic: single vanishing point perspective with colour, texture and shading.		Paper and drawing equipment	30/32	D33

<b>Term</b>	<b>Strand</b>	<b>Module</b>	<b>Unit</b>	<b>Time allocation (weeks &amp; hours)</b>	<b>Lesson</b>	<b>Activities</b>	<b>CAPS content, concepts and skills</b>	<b>Assessment tasks</b>	<b>Resources</b>	<b>LB page</b>	<b>TG page</b>
1	Mechanical systems and control	3: Mechanical systems and control	3.1: Simple mechanisms	7 weeks (14 hours)	Lesson 7	Activity 16a Activity 16b Activity 17	Lesson: Levers – mechanical advantage – simple qualitative treatment.  First-class levers: may give a mechanical advantage or not, depending on pivot position.	Motion and mechanisms Lever systems	Examples of mechanisms, such as: Scissors Tweezers Bottle opener Hammer Pliers Weighing scale Nutcracker  For pneumatics and hydraulics: Syringes – large and small Tubing to fit syringes Balloon Rubber bands Double-sided tape Sticky tape Cardboard	33/35 36 38	D35 D36 D37
					Lesson 8	Activity 18 Activity 19	Case study: First-class levers with mechanical advantage: MA > 1 MA = 1 MA < 1	First-class levers	Examples of first-class levers	38/40 41	D38 D39



Term	Strand	Module	Unit	Time allocation (weeks & hours)	Lesson	Activities	CAPS content, concepts and skills	Assessment tasks	Resources	LB page	TG page
1	Mechanical systems and control	3: Mechanical systems and control	3.1: Simple mechanisms (cont.)		Lesson 9	Activity 20 Activity 21	Second-class levers: Learners demonstrate models of second-class levers, which always give a mechanical advantage.	Second-class levers Systems diagram	Examples of second-class levers	41/42 43	D39 D40
					Lesson 10	Activity 22	Third-class levers: placed between effort and fulcrum. Learners demonstrate models of their-class levers which never give a mechanical advantage	The three classes of lever	Examples of each class of lever	43/44	D41
					Lesson 11 & Lesson 12	Activity 23 Activity 24 Activity 25	Investigation: Levers and linkages Examine linked first-class levers (e.g. pair of scissors, pair of pliers, hedge trimming shears).  Examine linked second-class levers (e.g. office punch, bicycle brake calliper, nut crackers).  Examine linked third-class levers (e.g. office stapler, pair of tweezers).	First and second-class levers	Examples of first and second-class levers	44 44 44	D42 D43 D44

<b>Term</b>	<b>Strand</b>	<b>Module</b>	<b>Unit</b>	<b>Time allocation (weeks &amp; hours)</b>	<b>Lesson</b>	<b>Activities</b>	<b>CAPS content, concepts and skills</b>	<b>Assessment tasks</b>	<b>Resources</b>	<b>LB page</b>	<b>TG page</b>
1	Mechanical systems and control	3: Mechanical systems and control	3.1: Simple mechanisms (cont.)		Lesson 13	Activity 26 Activity 27	Scenario: Impact of technology Emergency workers use the 'jaws-of-life' system to rescue trapped accident victims.  Lesson: Using pneumatics and hydraulics to enhance human strength.	Informal assessment task Topic: Mechanical systems and control Context: Jaws-of-life rescue system Content: Levers, linkages, hydraulics and pneumatics	An example of a pneumatic system	45/49 49/51	D44 D46
					Lesson 14	Activity 28a Activity 28b	Investigation: Force transfer between two equal syringes filled with 1) air and 2) water.  Investigation: Force transfer between two unequal syringes filled with 1) air and 2) water.	Investigation	Materials to build a pneumatic systems	51 53	D47
					Lesson 15	Activity 29 Activity 30	Design and make: Learners work in teams to develop a working model of a hydraulic-syringe powered, linked-lever rescue device using simple materials.  Design brief, specifications and constraints.	Investigation/ Research Communication	Examples of a rescue device	54 54	D50 D50

<b>Term</b>	<b>Strand</b>	<b>Module</b>	<b>Unit</b>	<b>Time allocation (weeks &amp; hours)</b>	<b>Lesson</b>	<b>Activities</b>	<b>CAPS content, concepts and skills</b>	<b>Assessment tasks</b>	<b>Resources</b>	<b>LB page</b>	<b>TG page</b>
1	Mechanical systems and control	3: Mechanical systems and control	3.1: Simple mechanisms (cont.)		Lesson 16	Activity 31 Activity 32 Activity 33	A 3-D drawing of the idea in oblique projection using dark and feint lines.  A sketch in single VP perspective enhanced using two of colour, texture or shading.  A working drawing in 2-D showing one view with dimensions to scale.	Graphic communication	Examples of 2-D and 3-D working drawings	55 55 55	D57 D53
					Lesson 17, 18 & 19		Make the working model.			55	D53
					Lesson 20			Summative assessment Formal Assessment Task: Test		55	D54
2	Structures	4: Structures	4.1: Introduction to structures	1 week (2 hours)	Lesson 1	Activity 1	Definition and purpose of structures to contain, protect, support and span  Classification of structures: natural and man-made	Identification of a structure's purpose	Examples of different structures: Can School desk School building	51/59	D66
					Lesson 2	Activity 2	Types of structures: shell, frame and solid	Peer	Examples of man-made and natural structures	60	D67

Term	Strand	Module	Unit	Time allocation (weeks & hours)	Lesson	Activities	CAPS content, concepts and skills	Assessment tasks	Resources	LB page	TG page
2	Structures	4: Structures (cont.)	4.2: Frame structures	1 week (2 hours)	Lesson 3	Activity 3 Activity 4	Investigate: a cell phone tower as a frame structure  Case study: examine existing towers strengthened by triangulation.  Evaluate: worksheet on advantages/ disadvantages of a landline phone vs. a cell phone	Teacher records findings on the broad peer assessment	Ice cream sticks A piece of string Matchsticks Stiff cardboard A punch Paper fasteners Newspaper Sticky tape Paper	63 64	D68
					Lesson 4	Activity 5 Activity 6 Activity 7 Activity 8	Action Research: Prac. – stiffen by tubing Prac. – stiffen by folding Prac. – strength of different shapes Prac. – stiffen by triangulation	Teacher assessment Self assessment	Examples of different shapes and their structural strength	64/65 67 67 69	D69- D70
			4.3: Investigate structures & 4.4: The impact of technology	1 week (2 hours)	Lesson 5	Activity 9	Investigate: A cell phone tower as a frame structure  Case study: examine existing towers strengthened by triangulation.  Evaluate: worksheet on advantages/ disadvantages of a landline phone vs. a cell phone	Peer assessment	Examples of structural elements of a tower made from beams and triangulation  Radio Cell phone	74/75	D72- D74

Term	Strand	Module	Unit	Time allocation (weeks & hours)	Lesson	Activities	CAPS content, concepts and skills	Assessment tasks	Resources	LB page	TG page
2	Structures	4: Structures	4.4: The impact of technology (cont.)		Lesson 6	Activity 10a Activity 10b Activity 11 Activity 12 Activity 13	Case study: The features of a school desk  Design brief  Case study: Radio/Cell phone features  Writing a design brief	Informal assessment task Topic: Structures Context: The cell phone tower Content: Frame structures	Examples of different types of desk and chair Examples of a radio and cell phone	76 77 78 79 79	D75 D75 D76
					Lesson 7	Activity 14	Write a design brief	Teacher assesses list Use rubric	Pencil Drawing paper Squared (quadrant) paper	80	D79
					Lesson 8	Activity 15	Sketch initial ideas 2 freehand sketches in 3-D Oblique projection Single vanishing point perspective  Blend tower into environment	Use rubric Teacher assesses sketches	Examples of a cell phone tower	83	D79
			4.6: Design ideas	1 week (2 hours)	Lesson 9	Activity 16	Evaluate sketches: Advantages/disadvantages Individual learners adapt their own sketches	Teacher assessment	Pencil Drawing paper Squared (quadrant) paper	84	D80

Term	Strand	Module	Unit	Time allocation (weeks & hours)	Lesson	Activities	CAPS content, concepts and skills	Assessment tasks	Resources	LB page	TG page
2	Structures	4: Structures	4.6: Design ideas (cont.)		Lesson 10	Activity 17	Working drawings Choosing materials and tools Individual lists	Teacher assesses list and drawings	Resources required for the project	86	D80
			4.7: Making skills and 4.8: Evaluation skills	$\frac{1}{2}$ week (1 hour)	Lesson 11	Activity 18	Teams select best plan from their group Develop the design chosen by the group The group adapts the final plan	Teacher assesses reasons	Pencil Drawing paper Squared (quadrant) paper	88	D81
			4.9: Making skills	3 weeks (6 hours)	Lesson 12	Activity 19	Build the model	Teacher assesses	For building the model: Straws Sosate sticks Dowel sticks Wooden sticks used for stirring tea/coffee Elephant grass Thin strips of thick cardboard Wire Cardboard  For the poster and presentation: Large sheet of cardboard/ paper Drawing and colouring materials	88	D81

<b>Term</b>	<b>Strand</b>	<b>Module</b>	<b>Unit</b>	<b>Time allocation (weeks &amp; hours)</b>	<b>Lesson</b>	<b>Activities</b>	<b>CAPS content, concepts and skills</b>	<b>Assessment tasks</b>	<b>Resources</b>	<b>LB page</b>	<b>TG page</b>
2	Structures	4: Structures	4.9: Making skills (cont.)		Lesson 13	Activity 20	Building the model	Teacher assesses	Resources required for building the tower	89	D83
					Lesson 14	Activity 21	Develop a rubric Design a poster using single VP	Teacher assesses	An example rubric for evaluation	89	D83
					Lesson 15	Activity 22	Presentations: 5 minutes each Plan joint strategy for presentations Present sketches, plans, models Each learner explains his or her role Poster: An artist's impression using single VP	Assessment in project in portfolios	Example poster	90	D83
					Lesson 16		Use rubric to assess other models during presentation	Teacher assessment using rubric	Example rubric	89	D83
					Lesson 17		Term Test	Summative assessment Formal Assessment Task: Test		91	D83

Term	Strand	Module	Unit	Time allocation (weeks & hours)	Lesson	Activities	CAPS content, concepts and skills	Assessment tasks	Resources	LB page	TG page
3	Electrical systems and control	5: Electrical systems and control	5.1: Investigation skills	1 week (2 hours)	Lesson 1	Activity 1 Activity 2 Activity 3	Investigate magnetism Different types of permanent magnets: Bar and horseshoe	Optional: recording poles using compass and magnet	Different types of magnet Iron filings Paper clips Nails Jar for iron filings Compass Wood Plastic Copper Coins Paper Squared (quadrant) paper Pencil	94 96 97	D87 D88
					Lesson 2	Activity 4	Optional extension: Find the shapes of magnetic fields using iron filings  Group work: Substances that stick to a magnet. Tabulate results	Research Recording Observation Tabulation of results	A magnet Different materials – magnetic and non-magnetic	98	D89
					Lesson 3	Activity 5	Metals attracted by a magnet Test metal samples Complete a table of the results  Case Study: Recycling scrap metals	Testing material samples Tabulate results Discussion ideas for raising funds	Magnets Different types of metal: Copper Lead Brass Aluminium Iron Steel Nickel Metal paperclips Metal paperclips with a plastic coating Paper Pencil	99	D92
			5.2: The impact of and bias in technology	1 week (2 hours)							



Term	Strand	Module	Unit	Time allocation (weeks & hours)	Lesson	Activities	CAPS content, concepts and skills	Assessment tasks	Resources	LB page	TG page
Electrical systems and control	5: Electrical systems and control	5.2: The impact of and bias in technology (cont.)	Lesson 4	Activity 6 Activity 7	Case Study: Recycling scheme for your school Tabulate a record of waste produced by your school Suggest a viable strategy to raise funds by recycling	Discussion Tabulation of waste materials	Examples of recyclable materials	100 102	D93 D94		
		Lesson 6	Activity 10 Activity 11 Activity 12 Activity 13	Work in groups to make a simple circuit Draw the circuit Demonstration: Electromagnet with switch	Making Drawing Demonstration	Examples of electromagnets, switches and circuits	106 107 107 109	D99- D101			

Term	Strand	Module	Unit	Time allocation (weeks & hours)	Lesson	Activities	CAPS content, concepts and skills	Assessment tasks	Resources	LB page	TC page
	Mechanical systems and control (continued from Term 1)	6: Mechanical systems and control (continued from Term 1)	6.1: Machines and mechanical advantage	6½ weeks (13 hours)	Lesson 7	Activity 14 Activity 15 Activity 16	Combinations of simple mechanisms.  'Mechanical advantage.'  Revise levers	Discussin Revision Extension	Photocopied worksheet on the different classes of lever Wheelbarrow for second-class lever demonstration A simple pulley system Drawing paper Pencil An electrochemical cell Tin foil Electrical tape A light bulb A soft iron core (e.g. a nail) A long length of insulated copper wire Pliers A switch (bought or homemade) Scissors Glue Wire Pliers Wheels for pulleys Nails and hammer Elephant grass or cardboard dowels for the structure Tape	110 111 113	D103 D104 D106

Term	Strand	Module	Unit	Time allocation (weeks & hours)	Lesson	Activities	CAPS content, concepts and skills	Assessment tasks	Resources	LB page	TG page
	Mechanical systems and control (continued from Term 1)	6: Mechanical systems and control (continued from Term 1)	6.1: Machines and mechanical advantage (cont.)		Lesson 8	Activity 17 Activity 18 Activity 19 Activity 20	Introduce cranks and pulleys  Revision: Mechanical advantage and strengthening frame structures	PAT 1 Topic: Electrical systems and control, structures, mechanisms Context: Recycling and impact Content: Structures and electricity, cranks and pulleys	Example of a crank Example of a frame structure	113 115 115 117	D106 D107 D108 D109 D110
					Lesson 9	Activity 21	Case Study: Pictures of cranes Design brief with specifications and constraints for a crane with an electromagnet	Discussion Observation Recording	Example of a crane	119	D114
					Lesson 10	Activity 22 Activity 23	Continue with design brief. Draw a circuit diagram for the electromagnet	Design Drawing	Examples of the various mechanisms for sorting magnetic metals	120 120	D114
					Lesson 11	Activity 24 Activity 25 Activity 26 Activity 27 Activity 28	Revision: Revise 3-D oblique drawing techniques, line types, scale, dimensions  Drawing: Oblique technique on squared paper	Revision of drawing techniques Final sketch	Examples of oblique drawing	122 123 124 124 125	D115 D116

Term	Strand	Module	Unit	Time allocation (weeks & hours)	Lesson	Activities	CAPS content, concepts and skills	Assessment tasks	Resources	LB page	TG page
	Mechanical systems and control (continued from Term 1)	6: Mechanical systems and control (continued from Term 1)	6.1: Machines and mechanical advantage (cont.)		Lesson 12	Activity 29	Sequence of manufacture of the crane with its electromagnet.	Flow chart	An example of a flow chart	125	D117
					Lesson 13	Activity 30	Make an electromagnet.	Making	An example of an electromagnet	126	D117
					Lesson 14	Activity 31	Make a model crane with a crank and pulley system	Making	An example of a crane	127	D118
					Lesson 15	Activity 32 Activity 33	Evaluate a product The above process is developed further.  Develop a rubric to evaluate the models of the other teams	Evaluation rubric	Establish the criteria for peer assessment	128 128	D118
					Lesson 16	Activity 34	Evaluate the models of the other teams.  Develop a strategy to present your model and plans to the class	Team evaluation Presentation	Continue establishing criteria for peer assessment	128	D119
					Lesson 17	Activity 35	Presents the design sketches, working drawings and functioning model to the class	Presentation Demonstration	Briefly revise the criteria for group presentations	128	D119
					Lesson 18	Activity 36	Explain the role each member played  Enhance the presentation using visual aids	Presentation	Establish the roles of each learner	129	D120

Term	Strand	Module	Unit	Time allocation (weeks & hours)	Lesson	Activities	CAPS content, concepts and skills	Assessment tasks	Resources	LB page	TG page
	Mechanical systems and control (continued from Term 1)	6: Mechanical systems and control (continued from Term 1)	6.1: Machines and mechanical advantage (cont.)		Lesson 19	Activity 37	Revision of Term 3	Revision activities	Revision	129	D120
					Lesson 20	Activity 38	Testing all knowledge gained in Term 3	Summative assessment Formal Assessment Task: Test		129	D120
4	Emergency situations	7: Emergency situations	7.1: Investigation skills	1 week (2 hours)	Lesson 1	Activity 1	Learners investigate emergency situations that can lead to people becoming refugees: Find out what situations commonly lead to people becoming refugees Find out the initial problems that are faced by refugees	Assessment of identification of disasters in the table	Pencil Additional examples of refugee situations	132	D124
					Lesson 2	Activity 2 Activity 3	What mix of people are usually present What are the needs for shelter? What are their needs for food and water?	Problems faced by refugees	Consider the problems faced by refugees and how they live	134 136	D125
			7.2: Emergency food	2 weeks (4 hours)	Lesson 3	Activity 4	Processing food: Emergency foods Investigate type of food that can be supplied to occupants in a refugee camp	Group investigative task	Worksheet of food for refugees The means to cook the meal Evaluation rubric Cooking utensils Cooking ingredients Apron and cap Dish cloth/oven gloves	137/ 138	D126

Term	Strand	Module	Unit	Time allocation (weeks & hours)	Lesson	Activities	CAPS content, concepts and skills	Assessment tasks	Resources	LB page	TG page
4	Emergency situations	7: Emergency situations	7.2: Emergency food (cont.)		Lesson 4	Activity 5	Write a design brief with specifications List the ingredients of a meal that will be nutritious as well as tasty and which can be prepared under conditions likely to be found in a refugee camp	Discussion Individual written activity	Consider practical meals that refugees will need	138/ 139	D129
					Lesson 5	Activity 6	Write down the sequence of manufacture for the process of preparing one item from the meal discussed above  Prepare a meal	Observation of item of meal prepared	Consider the order in which the stages of the meal will be prepared	140	D130
					Lesson 6	Activity 7  Activity 8	Evaluate the meal in terms of flavour, texture and nutritional value	Teacher to assess meal preparation Peer assessment of meal	Food for the meal Rubric for evaluating the meal	140/ 141 141	D131

<b>Term</b>	<b>Strand</b>	<b>Module</b>	<b>Unit</b>	<b>Time allocation (weeks &amp; hours)</b>	<b>Lesson</b>	<b>Activities</b>	<b>CAPS content, concepts and skills</b>	<b>Assessment tasks</b>	<b>Resources</b>	<b>LB page</b>	<b>TG page</b>
4	Emergency situations	7: Emergency situations	7.3: Investigate clothing worn by people in specialised occupations	5 weeks (10 hours)	Lesson 7	Activity 9	Investigate different clothing worn by people working in emergency situations	Uniforms appropriate to occupations	Additional examples of uniforms Additional examples of indigenous houses Pencil crayons or koki's or wax crayons A4 art paper Different types of textiles: cotton rayon polyester denim A pair of large braai tongs A candle in a stable candle holder A large metal container with water. Denim or canvas material cut into equal size pieces and labelled Chemicals: water based paint oil paint varnish silicone wood glue candle wax wax crayon A large container with water Food colouring	142/ 143	D132

Term	Strand	Module	Unit	Time allocation (weeks & hours)	Lesson	Activities	CAPS content, concepts and skills	Assessment tasks	Resources	LB page	TC page
4	Emergency situations	7: Emergency situations	7.3: Investigate clothing worn by people in specialised occupations (cont.)		Lesson 8	Activity 10 Activity 11	Learners find out what textiles are used to make clothing worn by firefighters	Completion of crossword puzzle	Examples of protective clothing	144/ 146 146	D133 D134
					Lesson 9	Activity 12	Building materials used by indigenous people in rural South Africa	PAT 2 Topic: Bias in and Impact of Technology Context: Shelters for refugees Content: Properties of materials	Examples of building materials	147/ 148	D135
					Lesson 10	Activity 13	Building materials used by migrant workers in informal settlements	Short questions and answers	Discussion of the conditions in informal settlements	149	D136
					Lesson 11	Activity 14 Activity 15	Chemicals used to waterproof textiles Burning characteristics of textiles	Flammable textiles Waterproof chemicals	Examples of flammable textiles	150/ 151 151	D136 D137
					Lesson 12	Activity 16	Design using free hand sketches of emergency shelters	Questions and answers	Materials for a shelter	152	D137
					Lesson 13/14	Activity 17	Write a design brief with specifications for a suitable textile that can be used to build an emergency shelter Make a model of an emergency shelter	Summative assessment Formal Assessment Task: Test	Materials to build a shelter	152/ 153	D138

**Section E: Photocopiable sheets - Record sheets and Assessment templates and worksheets**

**E1**

**Section F: Documents - Guidelines to strengthen CAPS**

**F1**





# Section A: Introduction



<b>Curriculum and Assessment Policy Statement (CAPS)</b>	<b>A3</b>
<b>Inclusivity</b>	<b>A6</b>
<b>Time allocation per subject</b>	<b>A10</b>
<b>Technology in the school curriculum</b>	<b>A10</b>
<b>Requirements for Technology</b>	<b>A15</b>



Welcome to **Technology Grade 7**. This course includes a Learner's Book and Teacher's Guide that provide the core material you need to cover the content required by the Curriculum and Assessment Policy Statement for Grade 7 Technology.

In the Introduction (Section A) you will find information about the core features of the National Curriculum and detailed advice on the Technology subject in particular.

Assessment is covered in Section B and explains how and when assessment should be done. Section B also contains control tests with memoranda that can be used at the end of each term.

Section C (Planning) contains a detailed phase plan, teacher plan (work schedule) and an exemplar of a lesson plan. The answers to all activities can be found in Section D. These include rubrics and checklists for formal and informal assessment of prescribed practical work.

Section E contains photocopiable worksheets, activities, rubrics and an exemplar of a recording sheet to record marks, and in Section F you can file your copy of the Curriculum and Assessment Policy Statement. You can also file your own documents in this section.

As a teacher at the General Education and Training (GET) level, your two main resources are:

- your expertise in the subject
- your teaching experience – knowing how to help learners master the skills and knowledge of this subject.

## **Curriculum and Assessment Policy Statement (CAPS)**

The new Curriculum and Assessment Policy Statement (CAPS) makes two core demands on you as the teacher:

- to follow a learning programme that enables learners to develop all the skills, knowledge, values and attitudes relevant to Technology
- to have a sound, up-to-date knowledge of the content and methods of your subject, and a clear understanding of its social relevance, so that you can act as a guide, facilitator and subject expert in the classroom.

This textbook helps you to meet these demands in the following ways:

- it provides a structure for your teaching programme for the year and a teaching plan (work schedule) that is in line with the CAPS requirements
- it provides solutions to all the activities in the Learner's Book
- it explains all the assessment requirements of the curriculum and provides practical activities with their rubrics and checklists that are required by CAPS
- it contains examples of generic rubrics, checklists and assessment sheets that you can use or adapt for your assessment work throughout the year.

## **General aims of the South African Curriculum**

The National Curriculum Statement Grades R to 12 gives expression to knowledge, skills and values that are regarded to be worth learning. This statement will ensure that learners acquire and apply knowledge and skills in ways that are meaningful to their own lives. In this regard, the curriculum promotes the idea of grounding knowledge in local context, while being sensitive to global imperatives.

## **The purpose of the National Curriculum Statement Grades R to 12**

The National Curriculum Statement aims to:

- equip learners, irrespective of their socio-economic background, race, gender, physical ability or intellectual ability, with the knowledge, skills and values necessary for self-fulfilment and meaningful participation in society as citizens of a free country
- provide access to FET and higher education

## **The principles of the National Curriculum Statement Grades R to 12**

The principles of the National Curriculum Statement are:

- social transformation
- active and critical learning
- high knowledge and high skills
- progression
- human rights, inclusivity, environmental and social justice
- valuing indigenous knowledge systems
- credibility, quality and efficiency.

These principles can be applied to your school context in the following way:

### **Social transformation**

What does this mean in your classroom? Your learners will come from families and communities that have been affected in diverse ways by South Africa's past. They will have many different ideas about the kind of future career they want and the kind of society they want to live in. In the learning programme that you plan for the year, you need to provide opportunities for the learners to analyse, research and come to understand the role that this particular subject plays in shaping the kind of society we want to create in South Africa and in offering them possibilities for their future.

For example: Create opportunities for learners to research and discuss questions such as how many people in their families have studied Technology and to what levels? How does access to Technology Education relate to access to different kinds of employment? What factors influence people's access to and success in the subject?

### **Active and critical learning**

What does this mean in your classroom? Many of the laws and principles in Technology have been developed and formulated over centuries.

You need to explain the background of how these laws and principles were developed and the meaning and application of their formulation. Make the learners aware that technological knowledge is man-made solutions or ideas to solve problems.

For example: Ways of processing food is to make food last longer and can change as new technologies become available.

### **High knowledge and high skills**

What does this mean in your classroom? You, as a subject expert, should inspire your learners with relevant knowledge and activities that will encourage them to want to explore Technology in depth. Encourage them to relate what they learn to their lives outside school and to possible future career paths. Strive to develop a high level of knowledge and skills in this subject in all your learners.

For example: Relate the study of particular Technology topics to future career paths such as electrical, chemical, and mechanical engineering, electrical and telecommunications technology. Where possible, create opportunities for learners to meet professional practitioners in these and other relevant fields. Set projects that challenge learners to apply their technology skills outside the school context. Inform them about what they can expect to learn if they follow these subjects in the FET and later on enrol for higher education in related technology subjects.

### **Progression**

What should this mean in your classroom? This Technology curriculum contains material at the appropriate level to meet the criteria required for Grade 7/8/9. If you plan a learning programme using this curriculum, you will ensure that your learners progress appropriately through the levels of knowledge and skills that the curriculum requires.

### **Human rights, inclusivity, environmental and social justice**

What should this mean in your classroom? In all activities that you organise and facilitate, create opportunities to relate Technology to the broader social goal of promoting human rights, environmental justice and social justice. Take into account that some of your learners might grapple with issues such as poverty, language and disability in their daily lives. Encourage them to explore these issues in ways that relate to this subject.

For example: Identify a social issue of relevance in the learners' community and help them research and design a technology solution to a community problem. This could relate to the availability of a bridge to cross a river or to design a two-way switch for a gate or a light in a passage.

## **Valuing indigenous knowledge systems**

What should this mean in your classroom? This Technology curriculum contains material that draws on indigenous knowledge systems and encourages learners to take these systems into account in their research and practical work. You should also draw on the expertise in your subject that may be available in your local community. Compile information about individuals and organisations in your region that can support your classroom work by means of relevant indigenous knowledge to which they have access.

Encourage learners to recognise sources of relevant indigenous knowledge in their own communities, and to include these sources in their research and practical work.

For example: People from indigenous cultures have always found ways to preserve food.

## **Credibility, quality and efficiency**

What should this mean in your classroom? The content of the Technology curriculum has been reviewed by experts in their fields of civil, electrical and mechanical engineers and covers all facets required to prepare learners to go on to FET.

## **Qualities and skills of learners**

The National Curriculum Statement aims to produce learners who are able to:

- identify and solve problems and make decisions using critical and creative thinking
- work effectively as individuals and with others as members of a team
- organise and manage themselves and their activities responsibly and effectively
- collect, analyse, organise and critically evaluate information
- communicate effectively using visual, symbolic and/or language skills in various modes
- use Science and Technology effectively and critically, showing responsibility towards the environment and the health of others
- demonstrate an understanding of the world as a set of related systems by recognising that problem-solving contexts do not exist in isolation.

## **Inclusivity**

Inclusivity should become a central part of the organisation, planning and teaching at each school. This can only happen if all teachers have a sound understanding of how to recognise and address barriers to learning and how to plan for diversity. We have included some guidelines below on how teachers can achieve the above.

Inclusive education and training should:

- acknowledge that all children and youth can learn, and that all children and youth need support
- accept and respect the fact that all learners are different and have different learning needs, which are equally valued
- enable education structures, systems and learning methodologies to meet the needs of the learner
- acknowledge and respect differences in children, whether due to age, gender, ethnicity, language, class, disability, HIV status, or any other reason
- maximise the participation of all learners in the culture and the curriculum of educational institutions and uncover and minimise barriers to learning.

What should this mean in your classroom? In this series of books the learners work together in groups and pairs, which gives them the opportunity to learn from each other, as well as at their own pace. The learning methodologies cater for learners with different learning abilities. Gender is also addressed as both boys and girls are able to participate in all the activities. Learners also have the opportunity to learn about diversity within the subject matter covered.

Learners with physical barriers can work in groups or with a partner so they can be assisted where necessary. The teacher must therefore group learners with disabilities together with learners with other disabilities or no disabilities so they can support each other.

### **Special needs**

In many classrooms, learners with special needs require additional attention; some learners require very little attention while others need more extensive help. As a teacher, be especially sensitive towards these learners without drawing too much attention to the learners' possible barriers to learning.

Discretely make the fellow learners aware of the need to treat each other with respect without exception. This vital life skill should be engrained in all young people so that it becomes part of their personalities for the rest of their lives. The information that follows will assist you in addressing some of these special needs in your classroom in an inclusive way. Be aware of these and other special needs of learners in your classroom.

**Partial sight or blindness:** For partially sighted learners who find it difficult to read text, you could enlarge the text by using a photocopy machine. Also, ensure that these learners sit in the middle at the front of the class so that their poor eyesight does not become a barrier to their learning.

Alternatively – and especially in group work – read the text aloud to these learners. Remind the learners to read loudly, clearly and slowly as partially sighted and blind learners rely heavily on their



memories. When doing experiments, these learners might not be able to see results. Train a few fellow learners with excellent social skills to convey results to their peers.

It is also a good idea to let these learners stay in the groups where there are learners you have trained specially to help their challenged classmates.

**Hard of hearing:** Once again, these learners should sit in the front of the class. When giving instructions, or when reading text to these learners, the speaker or reader should face the learner directly and speak loudly and clearly, but without exaggerating. Learners who are hard of hearing learn to lip-read very early in life.

**Impaired social skills:** The nature of these difficulties varies, but could, in some cases, become a serious barrier to learning.

- Learners who are very shy or highly-strung might find class presentation extremely stressful. Although you should encourage them to develop this life skill, remember that you can never change someone's nature completely. Work gently with these learners – their shyness or nervousness may be the result of negative circumstances at home. Let them present their 'class presentations' in written form at first, and then move slowly as the year progresses, at first letting them present their work to one classmate only, then to a small group, and finally to the whole class.
- Children with ADS (Attention Deficit Syndrome, also known as ADD, Attention Deficit Disorder) will find it extremely difficult to work in groups or to sit still and concentrate for very long – in some cases having to listen for two minutes is too long. Learners with ADS could affect the class atmosphere and class discipline in a negative way, and although everyone will agree that the deficiency is no fault of their own, they should not be allowed to ruin their fellow learners' education.

The school should have a policy that parents must inform the school confidentially if their child suffers from ADS. If learners have been diagnosed, they could be on medication. It is essential that teachers are informed; otherwise the learner could be branded as 'extremely naughty', which would be unfair and result in inappropriate handling. Teachers should be very careful not to judge a 'naughty' learner too soon. ADS is quite common, and in some cases may not have been diagnosed.

Look out for a learner who:

- finds it difficult or even impossible to concentrate
- frequently interrupts the teacher with irrelevant or seemingly ‘stupid’ questions
- fidgets all the time to the point of irritating peers
- jumps up frequently and asks to go to the bathroom (or somewhere else) at inappropriate times
- shouts out answers or remarks when the class has been asked to put up their hands
- is unable to deal with group work or pair sessions – these periods are interpreted as a ‘free for all’
- shows signs of aggression when fairly disciplined
- argues with the teacher when asked to keep quiet.

Please note that:

- the disorder is more prolific among boys than among girls
- diet could play a role in controlling the disorder – fast foods and junk foods should be kept to a minimum.
- **Extreme poverty:** This barrier to learning requires extreme sensitivity from the teacher. If you know that there are one or more learners in your class who come from poverty-stricken backgrounds, you could handle the situation as follows:

Learners are often required to bring resources from home, especially in practical learning areas like Physical Sciences. Some learners may be unable to afford additional resource materials: magazines for research; rulers; calculators and mathematical sets. Keep a supply of these items in your classroom without informing your learners and unobtrusively give them to those learners you know have difficulty in acquiring them. Be careful not to encourage ‘forgetters’ to make use of this offer! You could ask community groups in your area, such as churches, to provide support in collecting supplies of materials for you to keep in your classroom.

The key to managing inclusivity is ensuring that barriers are identified and addressed by all the relevant support structures within the school community, including teachers, District-based Support Teams, Institutional-Level Support Teams, parents and Special Schools as resource centres. To address barriers in the classroom, teachers should use various curriculum differentiation strategies such as those included in the Department of Basic Education’s *Guidelines for Inclusive Teaching and Learning* (2010).

## Time allocation

The instructional time in Grade 7 is shown in the table:

SUBJECT	HOURS
Home Language	5
First Additional Language	4
Mathematics	4,5
Natural Sciences	3
Social Sciences	3
Technology	2
Economic Management Science	2
Life Orientation	2
Arts and Culture	2
<b>TOTAL</b>	<b>27,5</b>

The allocated time per week may only be used for the minimum required NCS subjects as specified above. Should a learner wish to take additional subjects, these will have to be done outside this time.

## Technology in the school curriculum

### Purpose

Technology education was introduced into the South African curriculum in recognition of the need to produce engineers, technicians and artisans needed in modern society and the need to develop a technologically literate population for the modern world. The subject stimulates learners to be innovative and develops their creative and critical thinking skills. It teaches them to manage time and material resources effectively, provides opportunities for collaborative learning and nurtures teamwork. These skills provide a solid foundation for several FET subjects as well as for the world of work.

In the educational context, Technology can be defined as:  
*The use of knowledge, skills, values and resources to meet people's needs and wants by developing practical solutions to problems, taking social and environmental factors into consideration*

### Specific aims

Technology as a subject contributes towards learners' technological literacy by giving them opportunities to:

- develop and apply specific design skills to solve technological problems
- understand the concepts and knowledge used in Technology education and use them responsibly and purposefully
- appreciate the interaction between people's values and attitudes, technology, society and the environment.

The intention is to **introduce** learners to the **basics** needed in Civil Technology, Mechanical Technology, Electrical Technology and Engineering Graphics and Design. Additionally, learners gain an idea of the way engineers apply scientific principles to practical problems. In addition, **evaluation** skills will be fostered and the introduction of product **design** and **production** will be useful in other FET subjects that use these skills – such as Consumer Studies and Design.

It is expected that Technology education will provide learners with some experience to help them to make career-oriented **subject choices at the end of Grade 9**.

### **Unique features and scope**

#### **Key issues to teach:**

1. Problem solving using the design process
2. Practical skills
3. Knowledge and application of knowledge.

#### **Technology will give learners the opportunity to learn:**

- To solve problems in creative ways;
- To use authentic contexts rooted in real situations outside the classroom;
- To combine thinking and doing in a way that links abstract concepts to concrete understanding;
- To evaluate existing products and processes; and to evaluate their own products;
- To use and engage with knowledge in a purposeful way;
- To deal with inclusivity, human rights, social and environmental issues in their tasks;
- To use a variety of life skills in authentic contexts (such as decision making, critical and creative thinking, cooperation, problem solving and needs identification) while creating positive attitudes, perceptions and aspirations towards technology-based careers.
- To work collaboratively with others through practical projects using a variety of technological skills (investigating, designing, making, evaluating and communicating) that suit different learning styles.

## Topics and core content areas in Technology

The table below indicates the main focus areas in the Technology curriculum:

1.	The design process skills (non-linear) <ul style="list-style-type: none"> <li>• Investigation skills</li> <li>• Design skills</li> <li>• Making skills</li> <li>• Evaluation skills</li> <li>• Communication skills</li> </ul>
2.	Structures
3.	Processing of materials
4.	Mechanical systems and control
5.	Electrical systems and control
6.	Technology, society and the environment <ul style="list-style-type: none"> <li>• Indigenous technology</li> <li>• Impact of technology</li> <li>• Bias in technology</li> </ul>

There are four core content areas in Technology in Grades 7.

These are:

Structures	Processing	Mechanical systems and control	Electrical systems and control
------------	------------	--------------------------------	--------------------------------

*NB: All electric circuits must be battery powered in the GET Band - Max 9V dc*

These four content areas form the basis of the **four strands** which must be done each year in every grade. Where possible in the senior phase, the learner should engage in projects that **integrate** processing, structures and systems and control. The recommended approach will be to introduce the required knowledge followed by **practical** work in which the knowledge is applied. In all cases, the teaching will be structured using the ***Design Process*** as the backbone for the methodology. Some of these elements will be assessed formally each term. As learning progresses, learners must be made aware of the interrelationship between technology, society and the environment. Wherever applicable, learners should be made aware of different coexisting knowledge systems. They should learn how **indigenous cultures** have used specific materials and processes to satisfy needs, and become aware of indigenous intellectual property rights. Learners should be able to consider the **impact of technology**, both positive and negative, on people's lives. Learners should be made aware of **bias in technology** and be able to express opinions that explain how certain groups within society might be favoured or disadvantaged by products of technology.

### The importance of design in Technology Education

No product has ever been manufactured that did not undergo development through *design*. Technology education is an introduction to a range of careers that work in similar ways. All tend to use the

**design process** as they develop solutions to problems, needs or wants. The country needs informed, critical consumers and producers of knowledge.

A key element to teach is the ability to *design*.

With many similar products on the market, design excellence is a key element in attracting consumers.

### Examples of careers that use design:

Civil engineering - designing a bridge	Dietician - designing a diet to combat malnutrition and obesity
Architecture - designing a house	Mechanical engineering - designing a support system for the roof of a stadium
Textile design - developing a textile for a specific purpose	
Electrician - designing the electrical wiring for a lamp	

### Designers need to have...

- an **understanding** of the problem, need or opportunity;
- **knowledge** of the design process;
- **knowledge** of types and properties of suitable materials, and how to use them optimally;
- the ability to **calculate** the quantities and costs of the materials needed;
- **knowledge** of the conventions/building codes;
- an ability to **sketch** initial ideas on paper;
- the ability to **draw** working drawings in sufficient detail for the task;
- the practical skills required to **create a solution**;
- the ability to work **safely** using appropriate tools;
- the ability to adhere to health precautions;
- the ability to **present** the solution effectively to the client/customer.

Learners need to work collaboratively with others, doing practical projects using a variety of technological skills (investigating, designing, making, evaluating and communicating) to suit different learning styles.

### Teaching methodology (*how tasks will be approached*)

**NB:** As learners progress through a task, they must be **taught** the associated knowledge and the skills needed to **design and create** a solution.

Knowledge is important BUT the learners must show that they can **use the knowledge**, and not just memorise it.

The **Design Process** (Investigate, **D**esign, **M**ake, **E**valuate, **C**ommunicate – **IDMEC**) forms the *backbone* of the subject and should be used to structure the delivery of all learning aims. Learners should be exposed to a problem, need or opportunity as a starting

point. They should then engage in a systematic process that allows them to develop solutions that solve problems, rectify design issues and satisfy needs. *Investigation* in this subject involves finding out about *contexts and needs*, investigating or evaluating *existing products* in relation to key design aspects and *performing practical tests* to develop understanding of particular aspects of the content areas or determining a product's fitness-for-purpose. While investigating, learners should be provided with opportunities to explore values and attitudes and develop informed opinions that can help them to make compromises and value judgements. Investigation can happen at any point in the Design Process. It should not be seen as something that must be completed before design begins.

*Designing, making and evaluating.* These skills should not be seen as separate – they are interrelated.

**Evaluation** skills, for example, are used to choose ideas. At this level, learners should be introduced to key aspects of design. These should be used to evaluate both existing and designed products against predetermined criteria.

When **making**, learners should be encouraged to continue to reflect on their progress against these criteria and to modify their solutions based on problems encountered.

As learners progress they should be able to demonstrate *increasing accuracy and skill, better organisation and safer working practices.*

#### **Criteria for teaching and assessing design features:**

- Originality and aesthetics
- Value for money/cost effectiveness
- Fit-for-purpose and suitability of materials
- Ease of manufacture
- Safety and ergonomics
- Environmental impact
- Bias towards or against a group

*Communication* should also be seen as integral to the overall process. Learners should be recording and presenting progress in written and graphical forms on an on-going basis. Their presentations should show increasing use of media, levels of formality and conventions as they progress through the phase.

Technology develops valuable problem-solving skills that will benefit every learner in many life contexts.

**Note on drawing:** the Grade 9 learner must be able to *identify and explain a problem, need or opportunity from a given real-life context.*

In Grades 7–9 Technology, drawing is separated into three fields:

- **freehand sketches** in the **design stage**
- **working drawings** in the **making stage**, using formal draughting techniques in line with conventions
- **artistic impressions** in the **communication stage**, using artistic techniques including perspective, texture rendering, shading, colours and shadows in order to **advertise** the product to potential users.

**NB:** Perspective drawing here is purely **artistic** and has **no link** to the method of linking the perspective to the working drawing, using formal construction lines. In Technology, learners draw both technical AND artistic graphics.

### Time allocation for Technology

The teaching time for Technology is two (2) hours per week. As this subject involves practical work, 60 minutes of the two hours should be one continuous period for practical work, e.g. one double period comprising two periods of 30 minutes.

Schools using alternative period lengths, or a cycle system, must ensure that all subjects get their correct time allocation and that sufficient time is allocated for practical sessions.

### Requirements for Technology

1. Each learner must have:
  - An approved textbook.
  - A 72-page A4 exercise book. (In secondary schools learners may require two books per year.)
  - Stationery, including basic mathematical set (drawing instruments), pencil, eraser, ruler and set squares.
2. A designated teaching venue with a Technology teacher.
3. Technology rooms must be secure, with doors that lock, and with burglar-proofing if possible. Enough cupboards should be available to store and lock away all resources.
4. It is **the responsibility of the school** to provide each learner with the minimum tools and material to meet the needs of the subject (see Annexure B for possible tools and resources) and to develop the teacher's appropriate knowledge and skills.
5. **Enabling tasks:** Activities used to teach and then practise specific skills in preparation for a more advanced task – sometimes also called resource tasks. These tasks are assessed informally.
6. **PAT:** A Practical Assessment Task which makes up the main formal assessment of a learner's skills and knowledge application during each term. It may be an assignment covering aspects of the design process, or it may be a full capability task covering all aspects of the design process (IDMEC).



**Note:** The **curriculum for Grade 7** has been **described very specifically** to ensure that all these learners cover the same work in all schools across the country before graduating to secondary schools. Some limited variations will be developed by the various textbook authors.

The **curriculum for Grade 8** has some sections described fairly specifically while other sections give a lot of freedom for the innovation expected from textbook authors.

The **Grade 9 learners** have to be able to “identify a problem, need or opportunity” in a given context. Consequently the **curriculum for Grade 9** is non-specific and textbook authors have free reign to develop ideas that suit the **given content**.

## Section B: Planning



Teacher plan

B3

Lesson preparation

B3



## **Planning**

Teachers are involved in different levels of planning for each subject. These different levels of planning make up the learning programme for that subject.

A learning programme consists of a subject framework, work schedules and lesson preparations.

### **Teacher plan (work schedule)**

The teacher plan specifies the scope of learning and assessment for the three grades in a phase of the GET band. An overview of the knowledge areas and topics for Technology in the GET phase appears on pages iv–xi of this Teacher’s Guide.

The Curriculum and Assessment Policy Statement (CAPS) specifies the core knowledge and concepts to be covered during the GET phase, as well as the amount of time in hours and weeks to be devoted to each topic.

### **Lesson preparation**

A lesson preparation is a more detailed plan for a particular section of work, a period of time during the year or a particular lesson. It describes what learning is going to take place, and how it will take place. In addition to the information in the work schedule, it explains how the activities and assessment will take place as well as the use of resources. The lesson preparation also refers to prior and future learning.

You will need to carry out your own lesson preparation for your class.

Your lesson preparation will indicate when and how you will introduce each activity, each section of new knowledge, each assessment activity, and so on, using and expanding the information from the work schedule. We have included a blank lesson preparation form in Section E: Photocopiable resources, and an example of a completed lesson preparation in this section, to help you with your planning.

## Exemplar of Lesson Plan Grade 7

Term 4: Week 2 - Lesson 3 and 4	
<b>Teacher's name:</b>	
<b>Grade: 7</b>	<b>Time: 2 hour</b> <b>Date:</b>
<b>Focus: Processing - Investigation and design skills</b>	
<p><b>Content, concepts and skills:</b>            Processing food - emergency food            Design brief: learners write a design brief giving specifications of the types and quantities of food needed for a population of 100 refugees.</p> <p>Design: List the ingredients of a meal that will be nutritious as well as tasty, and which can be prepared under conditions likely to be found in a refugee camp.</p>	
<p><b>Prior knowledge: Investigation skills</b></p> <ul style="list-style-type: none"> <li>• Learners investigate emergency situations that can lead to refugees.</li> <li>• Find out what situations commonly result in people becoming refugees.</li> <li>• Find out what initial problems are typically faced by refugees:               <ul style="list-style-type: none"> <li>– What mix of people will usually be present?</li> <li>– What are their needs for shelter? (Shelter will be addressed in the PAT)</li> <li>– What are their needs for food and water?</li> </ul> </li> </ul>	<p><b>Next week:</b>            Making skills - Write down the sequence of manufacture for the process of preparing one item from the meal described above.</p> <ul style="list-style-type: none"> <li>• Learners prepare the item selected above.</li> <li>• Learners evaluate the item in terms of flavour, texture and nutritional value.</li> </ul>
<p><b>Teacher's activities:</b>            Explain that humans have basic needs of which one is food.            Learners investigate the types of food that can be used for the refugee camp that is easily available in their community.            Why do we need to use processed food?            Explain the conditions in a refugee camp.            Class discussions - Factors that need to be considered when feeding the refugees.</p>	<p><b>Learners' activities:</b>            Activity 4</p> <p>Activity 5</p>
<p><b>Resources:</b>            Pictures or examples of emergency and processed food.            If possible pictures or articles of refugee camps.</p>	
<p><b>Planned Assessment:</b>            Informal Assessment of activity 4 and 5.            This Informal Assessment gives the learners skills and leads up to the Formal Assessment</p>	
<p><b>Inclusive teaching and learning:</b> (Barriers, remedial and extension activities)            Be sensitive to learners coming from poor communities where food can be a scarce commodity.</p>	
<p><b>Teacher reflection:</b></p>	

## Exemplar of recording sheet

Note different methods to calculate the 40% SBA

Grade Class	Term 1			Term 2			Term 3			Term 4		SBA	Practical	Theory	Final
	Informal assessment task	Test 1	%	Code	Informal assessment task	Test 1	%	PAT 1	Test 1	%	Code				
Maximum marks	70	30	100		70	30	100		70	30	100	40	20	40	100
Date															
Learner names															



## Section C: Assessment



<b>Informal or daily assessment</b>	<b>C3</b>
<b>Using group and pair work</b>	<b>C4</b>
<b>Formal assessment</b>	<b>C6</b>
<b>Assessment tools</b>	<b>C10</b>
<b>Programme of Formal Assessment</b>	<b>C11</b>





## Assessment

Assessment is a continuous planned process of identifying, gathering and interpreting information about the performance of learners, using various forms of assessment. It involves four steps:

1. Generating and collecting evidence of achievement.
2. Evaluating this evidence.
3. Recording the findings.
4. Using this information to understand and thereby assist the learner's development in order to improve the process of learning and teaching.

Assessment should be both informal (assessment for learning) and formal (assessment of learning). In both cases regular feedback should be provided to learners to enhance the learning experience.

Assessment is a process that measures individual learners' attainment of knowledge (content, concepts and skills) in a subject by collecting, analysing and interpreting the data and information obtained from this process to:

- enable the teacher to make reliable judgements about a learner's progress
- inform learners about their strengths, weaknesses and progress
- assist teachers, parents and other stakeholders in making decisions about the learning process and the progress of the learners.

Assessment should be mapped against the content, concepts, skills and aims specified for Technology and in both informal and formal assessments it is important to ensure that in the course of a school year:

- all of the subject content is covered
- the full range of skills is included
- a variety of different forms of assessment are used.

### Informal or daily assessment

Assessment for learning has the purpose of continuously collecting information on learners' achievements that can be used to improve their learning. Informal assessment is a daily monitoring of the learners' progress.

This is done through observations, discussions, practical demonstrations, learner–teacher conferences, informal classroom interactions, etc. Informal assessment may be as simple as stopping during the lesson to observe learners or to discuss with learners how learning is progressing. Use informal assessment to provide feedback to the learners and to inform planning for teaching. Do not view informal assessment as separate from learning activities taking place in the classroom. The results of the informal daily assessment tasks are not formally recorded unless the teacher wishes to do so. Learners or teachers can mark informal assessment tasks. Self assessment and peer assessment actively involves learners in assessment.

This is important as it allows learners to learn from and reflect on their own performance. Informal assessment also helps learners to take responsibility for their own learning and for the learning of their peers. In this way they develop a sense of self-discipline and commitment to each other's wellbeing.

The results of daily assessment tasks are not taken into account for promotional and certificate purposes. Use informal, on-going assessments to structure the acquisition of knowledge and skills and as a precursor to formal tasks in the Programme of Assessment.

### **Using group and pair work**

Many teachers in South Africa work in overcrowded classrooms, which makes learning difficult. You can overcome some of these problems by getting a class to work in groups. Practical work is normally done in groups, while many activities lend themselves to work in pairs. Smaller groups are easier to handle and learners will also start to feel more positive about themselves.

Teamwork is an important aspect of learning skills and constructing knowledge. Sharing the workload and being aware of personal contributions to the community is important for every learner. In a group, the different roles and responsibilities people take on are essential to the success of the activity. At the GET level, learners should already become aware of the roles and responsibilities that are likely to be combined in 'professional' teams working in your particular subject areas in the real working world.

### **Setting up**

Certain learning tasks are better approached through a whole class session; others lend themselves to group work. Working in pairs and in groups of three to six learners, learners have a chance to express themselves more often than when they are part of a class of forty or more. They learn to work in a team, helping each other freely when their knowledge or skill is strong, and being helped when it is weak. Some learners might be too shy to ask a question in front of a whole class, but feel at ease asking a small group of friends.

### **Group work**

There are many ways of organising learners into groups. Here are some ideas:

- Language groups: If you have learners with different home languages, you can put the speakers of each language into their own language group. Same-language groups enable all the learners to develop their understanding of a new concept in their own language. At other times you can create mixed language groups. Learners working in their second language or third language can be helped with translation and have a greater chance to contribute than they would in a large class.
- Ability groups: There are times when it is useful to divide learners into groups according to how well they achieve in the learning

area. The top achievers in the class are grouped together, the average learners form a group, and the slowest learners are grouped together. Top achievers can do enrichment activities while you attend to the slower learners.

- Remediation groups: When you have finished assessing some aspects of the learners' work, you may often find a few learners from different groups with the same problem. There may be a new concept they haven't quite grasped, or a few learners may have been absent at the same time while you were dealing with new work. You can then group them together temporarily while you help them sort out the problem.
- Mixed-ability groups: These groups work well on their own while you circulate between them. Vary the members of these groups so that learners have experience in working with different classmates. For instance, new groups can be formed each time a new unit of work is started.

### **Guidelines for using group work**

- When planning group work, you should decide on the composition of each group and not always leave it to learners to cluster together with those they work with most easily.
- Divide tasks fairly among the members of each group and each member must understand his role.
- Give the learners clear and concise instructions.
- Define the work to be done clearly so that the group can go ahead without constantly referring to you.
- Learners must be settled and attentive when instructions are given.
- You must monitor progress at all times and should take into consideration not only the end result, but also focus attention on how the group has interacted and progressed through each step. This will be possible if you circulate amongst the groups and give information and guidance where and when it is required.
- Allow time for feedback so that learners have an opportunity to present evidence of their progress at the end of a session.
- Regular reminders of time limits and what progress should have been made at a particular stage are valuable when facilitating group work.
- Place groups as far apart as possible so that they enjoy a sense of privacy. Allow a certain amount of interaction as this often assists learners in solving problems or coping with complex areas.

### **Pair work**

Pair work is easier to control than group work, particularly in large classes where it is difficult to re-arrange the seating. It is a very useful strategy for task-based teaching as it frees the teacher to be a facilitator, support guide and evaluator.

Pair work also allows for differentiation: pairs that work faster can be given extra tasks; some pairs can be given more challenging tasks; in mixed ability pairing, one partner can assist the other.

### **Solving problems related to pair and group work**

- Noise can become a problem. Differentiate between ‘good learning noise’ and ‘disruptive chatter’. Firmly remind learners that they might be disturbing neighbouring classes and that they should keep their voices down.
- Certain learners dominate a group, while others are idle and not actively involved. Each individual must understand his or her role or task, which should be constantly monitored. Use the report-back to assess each learner’s involvement and progress.
- Learners may not like the partners they are paired or grouped with. There is no quick-fix solution to this problem. You must, however, use your knowledge of the learners and avoid grouping personalities or characters that are likely to clash.

### **Formal assessment**

All assessment tasks that make up the formal programme of assessment for the year are regarded as formal assessment. Formal assessment tasks are marked and formally recorded by the teacher for progression and certification purposes. All formal assessment tasks are subject to moderation for the purpose of quality assurance and to ensure that appropriate standards are maintained.

Formal assessment provides teachers with a systematic way of evaluating how well learners are progressing in a grade and in a particular subject.

Examples of formal assessments include tests, examinations, practical tasks, projects, oral presentations, demonstrations and performances.

The formal assessment requirements for Technology are as follows:

- Formal assessment for Technology will consist of the Practical Assessment Tasks and pen and paper tests or examinations.
- **At least 40 out of the 70 informal assessment taskmarks per term must be attributed to Practical work.**
- Tasks done by learners for formal assessment purposes should be monitored by teachers at all times.
- Work done “off-campus” outside the direct control of the teacher should normally not form part of the formal assessment record.
- The end of year promotion mark will comprise **40% SBA** and **60% (PAT 20% examination 40%) end of year examination:**

<b>Table 1: Formal Assessment in Technology - Grade 7</b>				
	<b>INFORMAL DAILY ASSESSMENT</b>	<b>FORMAL ASSESSMENT: TERM MARKS</b>		
		<b>Practical Task and Theory Test/Examination</b>		<b>TOTAL</b>
	<b>Enabling Tasks</b>	<b>Informal assessment task/PAT</b>	<b>Term Test/Examination</b>	<b>Term Mark</b>
Term 1	0%	70%	30%	100%
Term 2		70%	30%	100%
Term 3		70%	30%	100%
Term 4		70 marks = 100%	No Test	100%
<b>Promotion Mark</b>	<b>CASS Component: 40%</b>	<b>Final Examination Component: 60%</b>		<b>Promotion</b>
	<b>Continous Assessment: Test and PATs 40</b>	<b>Combined PAT: 20</b>	<b>Examination 40</b>	
	Term 1 + Term 2 + Term 3 + Term 4	T1 + T2 + T3 + T4	<b>40</b>	<b>100</b>
	<b>10 + 10 + 10 + 10</b>	<b>5 + 5 + 5 + 5</b>		

This breakdown is in line with the FET practical subjects where the PAT mark is included as part of the final examination component. In FET, the PAT mark contributes  $\frac{1}{3}$  of the final exam mark, i.e. 25 out of 75.

The above breakdown ensures that Technology in the GET band retains its focus on practical aspects. However, since GET Technology is not specialising as happens in FET, there are two informal assessment tasks and two PATs that need to be added together in equal portions to provide the practical examination component. As with the FET practical subjects, the combined PAT marks contribute  $\frac{1}{3}$  to the final exam mark, i.e. 20 out of 60.

The forms of assessment used should vary and be age- and developmental level–appropriate. The design of these tasks should cover the content of the subject and should include a variety of tasks designed to achieve the theoretical and practical objectives of the subject.

Formal assessment tasks form part of a year-long formal Programme of Assessment in each grade and subject, and should be adapted to meet the needs of inclusivity where necessary.

### **Control tests and examinations**

Control tests and examinations are written under controlled conditions within a specified period of time. Questions in tests and examinations should assess performance at different cognitive levels with an emphasis on process skills, critical thinking, scientific reasoning and strategies to investigate and solve problems in a variety of scientific, technological, environmental and everyday contexts. Examinations papers and control tests in Technology Grade 7 should adhere to the weighting of cognitive levels given in the table below. A detailed description of the cognitive levels follows on page B14.

RECALL	UNDERSTANDING	APPLICATION	ANALYSE	SYNTHESISE	EVALUATE
ROUTINE	DIAGNOSTIC	STRATEGIC	INTERPRET	CREATE	
Low Order	Middle Order		Higher Order		
30%	40%		30%		

### Practical Assessment Task (PAT)

**Definition:** a set of **practical** assessment tasks which make up the main formal assessment of a learner's skills and application of knowledge during each term. It may be an assignment covering aspects of the design process, or it may be a full capability task covering all aspects of the design process (IDMEC). It is composed of a variety of forms of assessment suited to the range of activities that make up a PAT.

**Purpose:** a PAT is intended to formalise the practical component of Technology contextualised within a knowledge focus. Practical activities should make up at least 40% of a PAT's mark allocation.

- The PAT is designed to give learners the opportunity to develop and demonstrate their levels of ability (i.e. capability) as they progress through the task's activities.
- Each PAT focuses **primarily** on one of the knowledge foci of Technology (viz. structures, mechanical systems and control, electrical/electronic systems and control and processing), but may be **integrated** and may target more than one knowledge focus.
- These tasks are structured according to the design process:

### Investigate - Design - Make - Evaluate - Communicate.

NB: *This is NOT a LINEAR process happening in a fixed sequence.*

- Assessment in a PAT need not cover all aspects of the design process each term.
- A PAT is an extended formal assessment task and must be planned with other school activities.

The table below provides a guide for the informal assessment tasks and PATs per term per grade:

	TERM 1	TERM 2	TERM 3 Capability task	TERM 4
GRADE 7	<ul style="list-style-type: none"> <li>• <b>Informal assessment task:</b> <i>Mechanical systems and control</i> Design + Make</li> </ul>	<ul style="list-style-type: none"> <li>• <b>Informal assessment task:</b> <i>Structures</i> Investigate + Design + Make</li> </ul>	<ul style="list-style-type: none"> <li>• <b>PAT:</b> <i>Electrical/ Structures/ Mechanisms</i> Investigate + Design + Make + Evaluate + Communicate</li> </ul>	<ul style="list-style-type: none"> <li>• <b>PAT:</b> <i>Processing</i> Design + Make</li> </ul>

- A learner must present the full design process once as a Practical Assessment Task in term 3 of each grade. This meets the requirement of one project per subject per annum.
- The preferred tool to be used to assess learner performance in a Practical Assessment Task is an **analytical rubric (refer to page E3)**.
- Teachers will assess skills and values using analytical rubrics which should have clear descriptors for each level. This means that a descriptor should say why an achievement is deemed to be, say, 'meritorious' or 'elementary'.
- Schools must take responsibility for providing resources (both tools and materials) needed during the PAT.
- Learners must complete the PATs for formal assessment under teacher supervision.
- Teachers will assess the PATs formally.

### Tests

- A standardised Test makes up 30% of each term's assessment.
- A test for formal assessment should cover a substantial amount of skills and content and should be set as follows: Grade 7: 45 minutes
- The mark for tests is not prescribed but should be determined by the teacher taking into account the volume of the content covered and the time available. Testing in Technology will be limited to ONE test each in terms 1, 2 and 3. This may take place either just before or just after the PAT, and must be planned in the school assessment programme.

### Informal assessment tasks and PATs

- The informal assessment tasks and PATs make up 70% of each term's assessment. Practical work must make up more than half of the marks.



## Examinations

- All examinations must include questions that integrate **knowledge** and **values** with **design process skills**.
- In Technology the final end of year exam comprises 60% of the learners' promotion mark and should be set out as follows:

Grade	Time allocation	Mark weighting
7	60 minutes	60 marks
8	90 minutes	100 marks
9	120 minutes	120 marks

- The content assessed at the end of the year is based on the year's work as specified in the CAPS document for the grade. However, prior knowledge from a previous grade may be necessary to interpret and answer some of the questions in the higher grade.

## Type of questions for Pen and Paper test

- The value of memorising by rote learning has little weight in a subject requiring *innovation, creativity* and *problem-solving skills*. The ability to *think laterally* and to develop *original* and *appropriate solutions* is a key element in learning Technology.
- Learners should be able to **investigate** using a variety of sources, demonstrate their ability to **draw** in a specific style, **write** a design brief, give specifications and constraints, **select** appropriate materials for a model, **plan** the sequence of manufacture of a product, **evaluate** a design objectively, **analyse** a system using systems diagrams and **communicate** their solutions using a range of techniques.
- Questions that integrate knowledge, skills and value have more value in technology than a mere recall of knowledge facts.

## The use of Case Studies

- Case Studies are used to bring reality into the classroom.
- The intention should be to show learners that Technology is a subject that is close to the way the world works.
- Case studies can be used both to develop and to assess a technological skill (drawing for example), knowledge concepts, and values.

## Assessment tools

### Checklists

Checklists consist of separate statements describing how the teacher can expect the learners to perform in a particular task. These statements are the criteria that the learners must meet to succeed. You need to observe that the learner has satisfied each statement on the list by doing what it describes.

## Rubrics

Rubrics are a combination of rating codes and descriptions of standards –that is what the learner must do, the level of competence, and so on – to be rated with a particular code. The rubric describes the range of acceptable performance in each band of the rating scale. Rubrics require teachers to know exactly what the learner must achieve – the level of competence, and so on – to meet the particular outcome being assessed.

To design a rubric, you need to decide on the following:

- What is the outcome that you are aiming at?
- What kind of evidence should be collected?
- What are the different parts of the performance that will be assessed?
- What different assessment instruments best suit each part of the task?
- What knowledge should the learners demonstrate?
- What skills should learners apply or what actions should they take?

It is crucial that you share the criteria in the rubric for the task with the learners **before** they do the required task. The rubric clarifies both what the learners should do and what they should be learning as they carry out the task. It becomes a powerful tool for self-assessment.

When the learners have completed the task and you are assessing their performance, you need to be sure that:

- each learner is assessed only once for each criterion within the rubric
- you add comprehensive comments where necessary for later moderation purposes.

## Rubrics and checklists in Technology

The generic rubrics and checklists are in Section E: Photocopiable resources. Modify them for your needs and use them as a guideline to help you develop rubrics specifically for your activities and projects.

## Programme of Formal Assessment

The Programme of Formal Assessment is designed to spread formal assessment tasks in all subjects in a school throughout a term and for the whole year. In addition to daily assessment (informal assessment), teachers should develop a year-long formal Programme of Assessment for Grade 7.

The learner's performance in this Programme of Formal

Assessment will be used for promotion purposes to Grade 7. Assessment is school-based.

The marks achieved in each of the assessment tasks that make up the Programme of Formal Assessment must be reported to parents. The table illustrates an assessment plan and weighting of tasks in the Programme of Formal Assessment in Technology Grade 7.

### End-of-year examination

The end-of-year examination papers for Grade 7 will be internally set, marked and moderated, unless otherwise instructed by provincial Departments of Education. The internally set, marked and moderated examination will consist of two papers. The table below shows the weighting of questions across cognitive levels and the specification and suggested weighting of the content for Grade 7 end-of-year examinations across two papers.

Investigate, design, make, evaluate and communicate	Structures, Processing, Mechanical and Electrical/ Electronic Systems and Control	(Technology, Society and the Environment) Indigenous/Impact/Bias
<b>Design Process Skills:</b>	<b>Knowledge:</b>	<b>Values and Attitudes:</b>
<b>50%</b>	<b>30%</b>	<b>20%</b>

NB: The above **weighting for assessment** should *guide the approach to teaching* in Technology. Most of the knowledge will be acquired purposefully during the development of design process skills. For example, learners will *investigate* required knowledge aspects, and will *evaluate* the possible impact on society or the environment.

### Recording and reporting

Recording is a process in which the teacher documents the level of a learner's performance in a specific assessment task. It indicates learner progress towards the achievement of the knowledge and skills as prescribed in the Curriculum and Assessment Policy Statements. Records of learner performance should provide evidence of the learners' conceptual progression within a grade and their readiness to progress or be promoted to the next grade. Records of learner performance should also be used to verify the progress made by teachers and learners in the teaching and learning process.

Reporting is a process of communicating learner performance to learners, parents, schools and other stakeholders. Learner performance

can be reported in a number of ways. These include report cards, parents' meetings, school visitation days, parent-teacher conferences, phone calls, letters, class or school newsletters, etc. Teachers in all grades report in percentages for the subject. The various achievement levels and their corresponding percentage bands are shown in the table below.

#### **CODES AND PERCENTAGES FOR RECORDING AND REPORTING**

<b>RATING CODE</b>	<b>DESCRIPTION OF COMPETENCE</b>	<b>PERCENTAGE</b>
7	Oustanding achievement	80–100
6	Meritorious achievement	70–79
5	Substantial achievement	60–69
4	Adequate achievement	50–59
3	Moderate achievement	40–49
2	Elementary achievement	30–39
1	Not achieved	0–29

**Note:** The seven point scale should have clear descriptions that give detailed information for each level. Teachers will record actual marks for the task by using a record sheet and report percentages for the subject on the learner's report card.

#### **Moderation of assessment**

Moderation refers to the process that ensures that the assessment tasks are fair, valid and reliable. Moderation should be implemented at school, district, provincial and national levels. Comprehensive and appropriate moderation practices must be in place for the quality assurance of all subject assessments. All Grade 7 tasks are internally moderated. The subject head or head of department for Technology at the school will generally manage this process.

#### **Assessment taxonomy**

The next table provides a possible hierarchy of cognitive levels that the teacher can use to ensure tasks include opportunities for learners to achieve at various levels and tools for assessing the learners at various levels.

The next table gives more information that can be used as a guide when setting papers.

Knowledge Recall	Understand	Apply	Evaluating	Analyzing	Synthesising
30%	40%		30%		
LOW	MIDDLE		HIGH		
Count Define Identify Label List Match Name Outline Point out Quote Recite Repeat Reproduce Select State Trace	Classify Compare Convert Discuss Distinguish Define Describe Estimate Explain Generalise Give examples Illustrate Infer Interpret Match Paraphrase Plan Restate Rearrange Rewrite Select Summarise Translate	Change Compute Construct Demonstrate Draw Illustrate Predict Relate Solve Use	Breakdown Differentiate Discriminate Investigate Relate Separate	Arrange Combine Compile Construct Create Design Formulate Generalise Generate Group Integrate Organize Summarise	Appraise Conclude Contrast Critique Criticize decide evaluate Grade Justify Interpret Support Recommend

### Summary of assessment

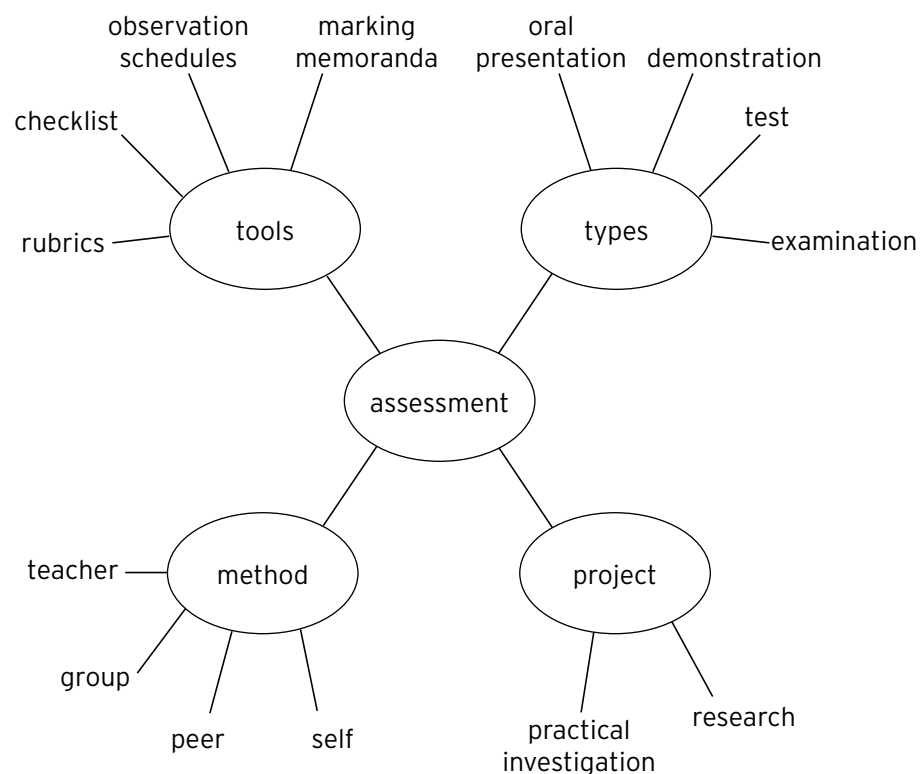

# Section D: Teaching Guidelines

## TERM 1

### Module 1: Design process skills

Unit 1.1 Introduction..... D5

Unit 1.2 Design considerations ..... D6

### Module 2: Communication skills

Unit 2.1 Introduction to graphical communication .....D14

Unit 2.2 Graphic techniques.....D30

### Module 3: Mechanical systems and control

Unit 3.1 Simple mechanisms .....D35

**Informal Assessment Task:** Mechanical systems and control .....D44

Context: Jaws-of-life rescue system; Content: Levers, linkages, hydraulics and pneumatics

**Formal Assessment Task: test**.....D54

## TERM 2

### Module 4: Structures

Unit 4.1 Introduction to structures .....D66

Unit 4.2 Frame structures .....D68

Unit 4.3 Investigate structures..... D72

Unit 4.4 The impact of technology..... D74

Unit 4.5 Design skills in structures..... D79

Unit 4.6 Design ideas..... D80

Unit 4.7 Making skills ..... D81

Unit 4.8 Evaluation skills ..... D81

Unit 4.9 Making skills..... D81

**Informal Assessment Task:** Structures

Context: The cell phone tower; Content: Frame structures/impact of technology ..... D81

**Formal Assessment Task: test** Mid-year exam .....D83

## TERM 3

### Module 5: Electrical systems and control

Unit 5.1 Investigation skills .....D87

Unit 5.2 The impact of and bias in technology..... D92

Unit 5.3 Electrical systems and control.....D95

### Module 6: Mechanical systems and control (continued from Term 1)

Unit 6.1 Machines and mechanical advantage ..... D103

**Formal Assessment Task:** PAT 1 - Module: Electrical systems and control/Structures/Mechanisms

Context: Recycling and impact; Content: Structures and electricity; cranks and pulleys ..... D110

**Formal Assessment Task: test**..... D120

## TERM 4

### Module 7: Emergency situations

Unit 7.1 Investigation skills .....D124

Unit 7.2 Emergency food.....D126

Unit 7.3 Investigate clothing worn by people in specialised occupations .....D132

**Formal Assessment Task:** PAT 2 - Module: Processing, bias in and impact of technology..... D138

Context: Shelters for refugees; Content: Properties of materials

**Formal Assessment Task: test** End-of-year Exam

**Informal assessment task**

In this term the learners will explore the question: what is Technology? They will also look at the Design Process, Communication and Levers, as well as pneumatics and hydraulics. They will also learn about the meaning of technology, the design process, design considerations, and different ways to communicate. Dimensioning and quantity, lettering and figuring, and design and drawing materials will also be looked at. You will also learn about colour, patterns, shading, painting, textures and shadows.

In the informal assessment task the learners are going to make a Jaws-of-life model system that is used to rescue trapped accident victims, and that emergency workers use during a life and death situation. The design will include making use of pneumatics and hydraulics to enhance human strength, together with levers and linkages. Therefore, as the learners go through the module this has to be kept in mind.

Here is an analytical rubric to assess design capability in the informal assessment task at the end of this module:

<b>The learner is able to:</b>					
<b>LEVELS OF COMPETENCE</b>					
	<b>Exemplary</b>	<b>Competent</b>	<b>Developing, but not yet mastered</b>	<b>Progressing</b>	<b>Progressing</b>
	<b>5</b>	<b>4</b>	<b>3</b>	<b>2</b>	<b>1</b>
<b>Generate and develop design ideas</b>	Using drawings reflectively to generate new ideas	Progression of ideas across or within drawing	Design ideas are generated but not developed	Simple sketch showing object to be made	Drawing a picture not designing a product
<b>Explore the possibilities of the problem/the need</b>	Combining novel solutions to produce innovative design	Using drawings to develop novel design solution/s	Recording possible creative solution/s to the task	Stereotypical response, showing little creative thought	Design possibilities are not addressed in the drawing
<b>Address the constraints of the problem/need</b>	Task constraints treated as part of iterative process	Task constraints considered as the design proceeds	Records way to address task and/or client needs and wants	Drawing show some understanding of task constraints	Minimal understanding of task/user needs
<b>Plan the look of the product</b>	Ideas about finishing are developed within overall designing	Ideas about finishing are added to design while drawing	Overall decoration scheme considered	Little consideration of final appearance of product	Appearance of the product is not considered
<b>Communicate design ideas</b>	Clear enough for somebody else to make the product	Conveys sense of the object to be made e.g. Working drawing	Conveys some sense of the object to be made e.g. indicates the materials	Simple unlabelled sketch(es); relying on shared meanings	Use of narrative or other drawing genre
<b>Plan construction</b>	Constructional issues considered on route to final design	Drawing demonstrates consideration of construction	Drawing indicates some consideration of construction	Minimal consideration of construction while drawing	Yet to define the design task
<b>Evaluate while drawing</b>	Changes made a result of considering design drawings	Decisions made about product while drawing	Considered and rejected a range of designs	Minimal evaluation at drawing phase	Yet to define the design task
<b>Provide a basis for making</b>	Using drawings as a resource during making	Clear development path through drawing into making	Object is one of the ideas drawn	Product relates to ideas recorded in the drawing	Making and object seen as separate new activity

Comments to improve the learner's performance in design capability:





## Unit 1.1 Introduction

## Week 1

## Lesson 1: What is technology?

The learners will learn the definition of 'technology', and who makes use of technology in the 'world of work'.

**Learning activities:**

- **Discussion:** You will discuss the definition of 'technology' with the learners.
- **Written Activity:** The learners conduct a survey at school to find out how other learners define technology. They will record the responses in their books.
- **Assessment Activity: Informal Educator Assessment:** You will check the completion of the tasks, the correction of the task, and listen to the responses.

**ACTIVITY 1** What is technology? LB p. 7

Group

The learners need to understand the different ideas about technology, and conduct a survey in the class or school campus to find out what technology means to each person. They will record their answers and discuss these in class during their technology period. Review their responses and compare them to the definition of technology in this book. In a group discuss the differences and similarities in the answers that you receive, and make your own judgment of how people define technology.

**ACTIVITY 2** The use of technology LB p. 7

Individual

The learners need to study the diagrams and state which of these they would describe as depicting technology. They will record their answers

in their exercise books.

**Learning activities:**

- **Discussion:** All of the illustrations depict technology. All are forms of communication:
  - A. Caveman painting. This type of painting made use of paint that lasted through millions of years.
  - B. Mail runner. This is an early form of mail delivery service in the olden days.
  - C. Smoke signals. Native Americans used this method thousands of years ago to send signals to nearby tribes and is an early form of communication
  - D. Stage coach mail service. This is another type of mail delivery service.
  - E. A modern communication device. This is a setup of all the technological gadgets that we use today in order to communicate, such as the telephone, fax computer, and email.
  - F. A town crier. This is a person who once read the news in the town square and was a form of early spoken newspaper.
- **Written Activity:** The learners should discuss these pictures in class and record their answers in their exercise books.
- **Assessment Activity: Informal Educator Assessment:** You will check the completion of the tasks, the correction of the task, and listen to the responses.

**ACTIVITY 3 Technology at work LB p. 8**

Individual

The learners need to record their answers to the following questions in their exercise books: Look at the previous pictures and note: who makes use of technology in the ‘world of work’?

## Unit 1.2 Design considerations

### Week 1

#### Lesson 2

In this lesson the learners will learn about the technological process.

**Learning activities:**

- **Discussion:** The learners will discuss the steps in the technological process. The design process involves the following basic steps:
  - **Investigate:** Find, use and acknowledge information for the design process.
  - **Design:** Write and draw a design brief with specifications and constraints. This will include the learner’s initial idea sketches. They then choose the best design and select materials for it.
  - **Make:** Draw plans of the design process. Develop the manufacturing sequence, which is the order in which you will make your item or model. The learners may next make the item

or model.

- **Evaluate:** The learners need to evaluate both their design stage and their final product.
- **Communicate:** The learners need to present your solutions. To do this, the learners compile all notes and drawings of the design process into a project report in their exercise books.

### Tip

- Make a large poster for the wall of the cyclic diagram of the design process. This will help the learners get the order correct and keep them focussed on their task. They will also realise that they can go back to the different steps if they think of some new ideas for their design.

### Design considerations

- **Fitness-for-purpose:** When the learners are designing something for someone or even for themselves, there are certain questions that they need to ask. These explain whether their design considerations fit the purpose for what it is to be used or not. They need to ask:
  - Who is it for?
  - What is it for?
  - Will it do the job?
  - Is it cost effective?
  - Is it safe?
  - Is it easy to use (ergonomics)?
  - Does it look good (aesthetics)?
  - Will it affect society?
  - Will it affect the environment?

Ask the learners questions relating to technology to determine what they did in the previous grade. Take a cool drink can or any other product and engage the learners in a class discussion with the following questions and instructions:

1. What is the need or problem that the product solves?
2. Name the design features of the product.
3. What relevant knowledge and skills are required to make the product?
4. From what material is the product made?
5. What manufacturing process was used to make the product?
6. What criteria would you use to evaluate the effectiveness of the product?
7. Sketch the product on an A4 sheet of paper.

Divide the learners into groups of five. Each group selects a different product that is available in the classroom and discusses the product in relation to the questions above. Each group gives feedback to the class.

- Give the learners a worksheet based on technological knowledge areas and technological process skills. It should contain a picture

or illustrations. This can be used as a baseline activity.

- Show examples of the best practice from the previous year's work.
- The learners review the week's learning and reflect on the progress that they have made.
- **Written Activity:** The learners attempt to move a stack of books making use of pencils as rollers under the books, and thus employ the technological process. They will then record how they will follow the technological steps in their exercise books.
- **Assessment Activity: Informal Educator Assessment:** You will check the completion of the tasks, the correction of the task, listen to the responses and conduct the experiment in class.

### Did you know?

Discuss the different bookmarks in the photos on page 12 of the LB. Some look homemade, some are very creative. The teacher can discuss how everyone has different tastes and everyone is different when it comes to choosing their favourite one.

### Hint

The teacher can encourage learners to bring bookmarks from home or pictures of bookmarks in magazines. Some learners may not have seen a bookmark before. The teacher should have a display in the classroom. Not everyone has a collection of books to read at home. Often the learners don't even have electricity at home for light to read and do their homework.

## ACTIVITY 4 Designing a bookmark LB p. 10

Pairs

The learners need to think back to a time when early people decided to move large objects around the countryside. In pairs, they need to consider the question: how do you think they managed to do this? The learners need to make notes of the points that they come up with. Hint: Move a pile of books on your desk using pencils or any cylindrical tube.

### Focus: The technological process

The learners learn about writing a design brief.

### Learning activities:

- **Discussion:** The learners are taught how to write a design brief. They will make use of the bookmark project to write a design brief. Explain the background by reading the scenario and identifying key aspects. The learners read the given scenario

on their own and write a design brief, and list constraints and specifications. Instruct the learners to sketch some design options according to their design brief. The learners write notes to clarify the design features

- **Written Activity:** Write the design brief.
- **Assessment:** The design brief should be assessed.
- **Informal Educator Assessment:** You will check the completion of the tasks.

## **ACTIVITY 5** The design brief for your bookmark LB p. 11

Individual

### **Case Study**

The learners need to write a design brief that will state clearly what they are required to do to solve the problem with the books. They should record this in their exercise books or portfolio.

**Resources Needed:** pen and exercise book, checklist.

### **Writing a design brief**

The learners' design brief must be a short statement of the problem to be solved and not a description of the solution. An open brief allows for more creativity than a closed brief, which describes a solution.

<b>What follows is a checklist for a design brief</b>		
<b>Checklist Criteria</b>	<b>Yes</b>	<b>No</b>
It is a short, clear statement of what must be done.		
It describes the problem and not a solution.		
It describes who will use it.		
It describes where it will be used.		
It describes the benefit a solution will have.		
Listing constraints		

The factors that will limit design ideas are the constraints. These can be stated as one word, such as time, materials, tools, human resources and cost. These must be considered prior to listing the product specifications.

### **Focus: The technological process**

The learners learn about investigating possible solutions to their problem.

### **Learning activities:**

- **Discussion:** The learners will investigate other examples of bookmarks. They will design their own solutions. At least three drawings should be presented. They need to take ergonomics into consideration as well as aesthetics. Each learner in the group should sketch his or her own ideas as the group discusses ways to solve the problem. Labels and arrows should be included to identify parts and

how they might move. These drawings should be quick and brief.

- **Drawing Activity:** The learners will draw three possible solutions to their problem. In this step, each learner should develop two or three ideas more thoroughly. The learners should create new drawings that are orthographic projections (multiple views showing the top, front and one side) and isometric drawings (three-dimensional depiction). These are to be drawn neatly, using rulers to draw straight lines and to make parts proportional. Parts and measurements should be labelled clearly.
- **Assessment:** The possible solutions are assessed. The developed ideas should be shared and discussed among the team members. The learners should record pros and cons of each design idea directly on the paper next to the drawings.
- **Informal Educator Assessment:** You will check the completion of the tasks. **Additional Resources:** You need to provide maths sets, pencils, rulers and A4 drawing sheets.

### **Extension Activity/Homework Activity**

The learners research solutions to their problems at libraries, on Internet and in bookshops. The learners will construct a full-size or scale model based on their drawings. You will help the learners to identify and acquire appropriate modelling materials and tools. See the design brief for a sample list.

This is a critical stage of the design process and requires detailed instructions regarding the making of a solution. Plans for creating a solution should have sufficient detail for another person to make the solution.

Aspects to consider and plan for are the materials to be used and the tools needed to make the completed solution. Safety and efficiency are critical aspects that must be focussed on during the making process.

### **ACTIVITY 6** How to make the bookmark LB p. 12

Individual

In this activity the learners design possible solutions to their bookmark problem. The following questions may assist them to make what they have designed:

- What tools have you chosen to complete your design? Scissors, utility knives
- What materials have you chosen? Leather, cardboard, plastic
- What process are you going to begin with and what processes will you following until your design is completed? The learners will follow the technological process.

**Resources Needed:** Ruler, pencil, felt pens, paint, glue, paper punch, scissors, utility knives, material (leather, cardboard, plastic), maths sets, stencils, self-assessment of design brief and drawings, use of a checklist.

### **Extension Activity/Homework Activity**

The learners should work in teams and identify the design that appears to solve the problem in the best way. The learners should write a statement that describes why they chose their particular solution. This should include some reference to the criteria and constraints identified above.

Three-dimensional sketches are best suited to show design ideas. They should use notes with freehand sketches and enhance designs using colour, tone, shade, texture and thick and thin lines.

Formal drawing conventions are used to show the final design plan as a working drawing. Accuracy is important when completing the formal drawings. Grid paper can be used as a guide for sketching and doing formal drawings. When sketching or drawing a three-dimensional view of an object it is a good idea for the learner to draw the item in the box that it will fit into (called crating). They will then add thick and thin lines and render and enhance it as required. Working drawings include dimensions, notes that indicate material, construction methods and finish.

### **Learning activities:**

- **Discussion:** The learners will evaluate their projects against specific criteria.
- **Written Activity:** The learners will examine and evaluate their prototypes or designs based on the criteria and constraints. Groups may enlist learners from other groups to review the solution and help identify changes that need to be made. Based on criteria and constraints, teams must identify any problems and proposed solutions.
- **Extension Activity:** Bubble charts or spider diagrams are suitable methods of presenting the analyses of a scenario. The following questions will help identify the key areas that may require more investigation or research:
  - What is the problem, need or opportunity?
  - Who will use the solution?
  - Where will it be used?
  - When will it be used?
  - How will it be used?
  - Why is it needed?
  - What do similar solutions look like?
- **Assessment:** Each project will be graded against specific criteria together with the project portfolio.
- **Informal Educator Assessment:** You will check the completion of the tasks.



## ACTIVITY 7 Evaluating your bookmark LB p. 12

Individual

### Case Study

Evaluating and testing is one of the most important parts of the design process. Learners should be critical of their work and change their design if they think it is necessary:

- Is it aesthetic?
- Is it ergonomically designed?
- Does it fit the purpose for which it is designed?
- Can the design be improved on to meet all the criteria required?

The learners should record their answers in their exercise books.

**Resources Needed:** A mark sheet for each learner to record his or her marks against each criterion.

### Extension Activity/Homework Activity

#### Learning activities:

- **Discussion:** The evaluation process is not just an account of what was done nor is it a list of opinions. It is a 'scientific process' to verify design procedures. An evaluation scale is used to rate each specification on a given scale. Testing, however, has to do with a practical activity that tests the functioning of the product. The learners must use the opinion of others to support suggestions for any changes or improvements to be made.
- **Written Activity:** Design a checklist to evaluate the product.
- **Informal Educator Assessment:** You will check the completion of the tasks.

## ACTIVITY 8 Presenting your bookmark to the class LB p. 13

Individual

### Case Study

In this activity the learners are expected to present their bookmark and logo to the class and explain why they decided on particular features, such as the size, colour and font, in this case. This can be done in words and with graphic drawings. The learners will record their progress in their Project portfolio. This activity will require an oral presentation from the learners.

**Resources Needed:** laptop, data projector, flip chart, portfolio, posters, large sheet of paper.

## Extension Activity/Homework Activity

### Focus: The technological process

The learners learn about assessing their projects against specified criteria.

#### Learning activities:

- **Discussion:** The evaluation process is not just an account of what was done nor is it a list of opinions. It is a 'scientific process' to verify design procedures. An evaluation scale is used to rate each specification on a given scale. Testing, however, has to do with a practical activity that tests the functioning of the product. The learners must use the opinion of others to support suggestions for any changes or improvements to be made.
- **Written Activity:** Complete a worksheet on the design considerations and its fitness for purpose.
- **Informal Educator Assessment:** You will check the completion of the tasks.

### ACTIVITY 9 Your bookmark's design LB p. 13

Individual

#### Case Study

- **Design considerations:** Fitness-for-purpose  
In this activity, after completing their project and presenting it to the class, the learners are expected to assess the project in terms of the following criteria:
  - Who is it for?
  - What is it for?
  - Will it do the job?
  - Is it cost effective?
  - Is it safe?
  - Is it easy to use (ergonomics)?
  - Does it look good (aesthetics)?
  - Will it affect society?
  - Will it affect the environment?

The learners should record their answers in their exercise book. They should make use of peer assessment in this activity to ascertain the accuracy and efficiency of their product.

## Unit 2.1 Introduction to graphical communication

### Week 2

#### Lesson 3

This week introduces the learners to graphical communication. They will cover the purpose of graphics and how they develop and communicate ideas. The conventions of lines such as thin/dark outlines, thin/feint construction lines, dashed lines for hidden detail, and scale and dimensioning will be looked at. Freehand sketching will also be looked at. Two-dimensional working drawings of ONE face of an object using conventions will be done by the learners.

#### Learning activities:

- **Discussion:** Introduce the lesson by explaining to the learners that in order for anyone to be able to understand exactly what a drawing represents, sets of precise rules and conventions have to be followed, much like a language. These rules are usually referred to as 'Standards'.

When a designer works with an engineering drawing he or she must be familiar with the precise meaning of the various line styles, abbreviations, drawing simplifications and terminology as specified in the relevant standards. This section introduces you to some of the conventions defined in the SABS Code of Practice for Engineering Drawing.

Standards are developed both privately by companies and by internationally recognised institutions.

Two such international standards are:

- British Standard Institution: BS 8888 (Superseded BS 308)
  - American National Standards Institute: Y14 series
- **Written Activity:** As a written activity the learners should fill in a survey form which you need to assess.
  - **Informal Educator Assessment:** You will check the completion of the tasks, oral presentation and the findings.

## ACTIVITY 10 Survey on the purpose of graphics LB p. 15

Individual

### Case Study

Conduct an online survey at the school, enquiring from them what they think is the purpose of graphics. Design an online survey sheet, and conduct this interview. Record your answers and discuss them in class in the next period.

This will require questions for the survey handout.

It is important to design questions very carefully:

- Make items clear (the person you are questioning might not know the terms you are using).
  - Avoid double-barrelled questions (the question should ask one clear thing).
  - Don't ask questions that the respondent won't accurately be able to answer.
  - Questions should be relevant.
  - Short items are best.
  - Avoid negative items.
1. The learners need to design the survey interview sheet first.
  2. They will then do the survey.
  3. They will record the information given to them.
  4. They will discuss the results.

### Extension Activity/Homework Activity



Allow the learners to find out how to write a survey form and what information goes into it.

### Focus: Graphical communication

The learners learn about the different types of lines used in drawing and their meanings.







### Learning activities:

- **Discussion:** Take the learners step by step through the different types of lines that we use in drawing and what each line represents. Make a worksheet to remind the learners of what they have learnt by filling in the line type and the application. Follow the illustration below.

LINE TYPE (thickness)	EXAMPLE	APPLICATION
Continuous 0.7mm thick	A 	Visible outlines/border lines
Continuous 0.3mm thin	B 	Dimension lines/projection & leader lines/hatching

## Hint

Make the table of line types into a poster. Use string to make the different lines. Glue the string and cut where necessary. This will help the visual learners as well as learners who are visually challenged.

Short dashes 0.3mm		Hidden detail
Long chain 0.3mm		Centre lines
Chain, thick at ends 0.7 - 0.3mm		Section-cutting planes
Short chain 0.3mm		Developed views
Continuous wavy boundaries 0.3mm		Broken
Straight zigzag 0.3mm		Break lines
Straight lines with dimension lines, two short zigzags 0.3mm		Dimension lines

### Supply list:

- Scaled drawings 2D worksheet
- Scaled drawings 2D HW
- Rulers, compasses, protractor, French curves and other drawing tools
- Graph paper (preferably with lines in metric distances)
- Simple 3-D objects (plastic pencil sharpener, tape dispenser, battery, coffee mug)
- Transparencies/handouts of actual drawings of the items.

NB: This can be used for all graphic communication.

## ACTIVITY 11a Types of line in graphical drawings LB p. 18

Individual

### Case Study

Name four types of line used in graphical drawings and state the use of these lines in these drawings. Record your answers in your exercise book.

- **Written Activity:** The learners name four types of lines that they have learnt about.
- **Assessment:** The learners' responses are assessed.
- **Informal Educator Assessment:** You will check the completion of the tasks.

**Additional Resources:** You should provide an example of a SANS document.

**Resources Needed:** pen and exercise book

## Focus: Graphical communication

The learners learn about types of lines.

### Learning activities:

- **Discussion:** Discuss the various types of lines and their uses. The learners are expected to recognise these lines from the diagram given.
- **Written Activity:** The learners need to complete the task given.
  - Visible outline
  - Hidden detail line
  - Centre lines
  - Section lines
  - Extension lines
  - Dimension lines
- **Extension Activity:** Any task can be designed by you and given to the learners based on type of lines.
- **Assessment:** You should mark the answers to the questions about the recognition of lines.
- **Informal Educator Assessment:** You will check the completion of the tasks and mark the activity.
- **Additional Resources:** A worksheet on the type of lines and their uses should be given to the learners.

### Extension Activity/Homework Activity

The learners should find out more about the language of lines.

#### ACTIVITY 11b Identifying line types LB p. 18

Individual

### Case Study

The figure in the Learner's Book illustrates a typical application of line types. Identify each of the lines shown in this diagram and state the use of each line. Learners will record their answers in their exercise books.

**Resources Needed:** The learners will need a chart on lines and their uses.

### Extension Activity/Homework Activity

#### Extension Exercise 1

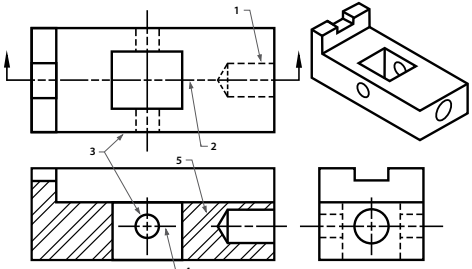
	<ol style="list-style-type: none"><li>1. Hidden detail line</li><li>2. Section line</li><li>3. Visible outline</li><li>4. Centre line</li><li>5. Centre line</li></ol>
--	--

## Extension Exercise 2

1. Hidden detail line  
2. Visible outline  
3. Centre line

Notice that the dashes cross at the centre.

Notice that the centre lines connect indicating that the hole lines line up.

### Focus: Graphical communication

The learners learn about preserving metals by painting and galvanizing them.

#### Learning activities:

- **Discussion:** Discuss the drawing with the class. Demonstrate on the board how to do this drawing. Discuss the dimensions of the drawing. Show the learners how to draw circles and curves using a compass. Explain that sectioned parts need to be drawn at 45° angles and at 3mm apart. The learners are required to use the lines that they have learnt about in order to complete these drawings using instruments.
- **Drawing Activity:** The learners draw the given drawing on A4 size paper.
- **Assessment:** This will be marked by you using the grid provided below.

Criteria	5	4	3	2	1	0	Total
1. Accuracy of drawing							
2. Makes use of scale							
3. Makes use of all relevant lines							
4. Prints neatly and accurately							
5. Dimensions the drawing correctly							
6. Demonstrates good aesthetic design							
7. Total							

- **Informal Educator Assessment:** You will check the completion of the tasks and assess the drawing.
- **Additional Resources:** The learner will make a tracing of the drawing to check for accuracy of detail, maths sets, drawing boards, A4 paper and eraser.

## ACTIVITY 11c Scale and orthographic projection drawings LB p. 18

Individual

### Case Study

The learners need to copy the drawings below on a blank sheet of paper and include the hidden detail lines on their drawing. They should remember that hidden detail lines are drawn 3mm long with a space of 2mm between them.

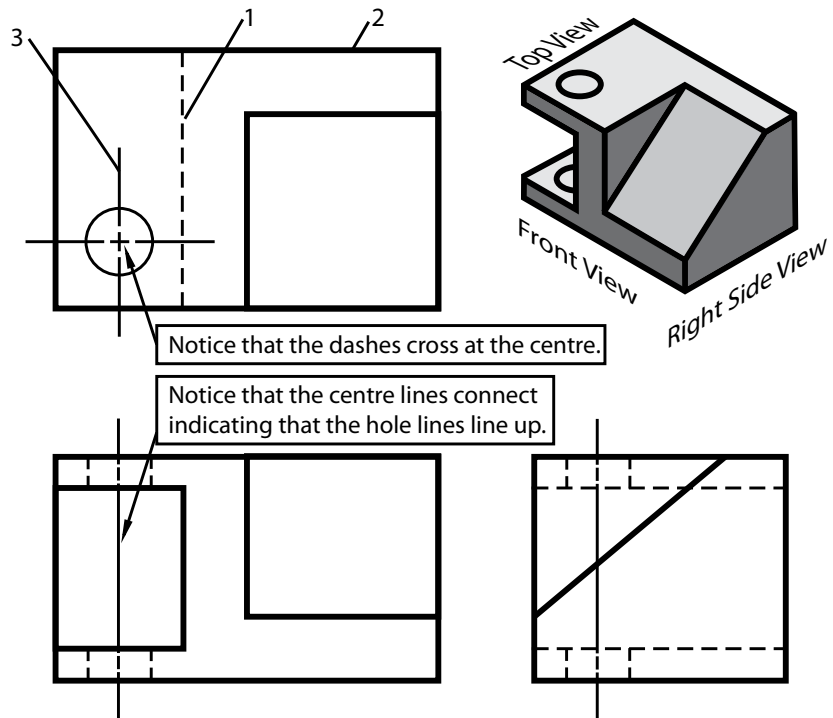

**Resources needed:** Maths sets, drawing boards, A4 paper, and eraser.

### Extension Activity/Homework Activity:

The learners should complete the above work for homework if they do not complete it in class.

### Focus: Graphical communication

The learners learn about first angle orthographic projection and how to draw hidden detail lines.

### Learning activities:

- **Discussion:** You need to discuss the drawing with the learners. Demonstrate on the board how to do this drawing in first angle orthographic projection. Discuss the dimensions of the drawing. Indicate on the board how to draw hidden detail lines.
- **Written/Drawing Activity:** The learners draw the given drawing on A4 size paper.
- **Extension Activity:** Discuss in detail how to draw a first angle orthographic drawing.
- **Assessment:** The drawing will be assessed using the rubric provided on the next page.



Criteria	5	4	3	2	1	0	Total
1. Accuracy of drawing							
2. Makes use of scale							
3. Makes use of all relevant lines							
4. Prints neatly and accurately							
5. Dimensions the drawing correctly							
6. Demonstrates good aesthetic design							
Total							

- **Informal Educator Assessment:** You will check the completion of the tasks.

**Additional Resources:** A trace of the drawing should be made to check for accuracy of detail, maths sets, drawing boards, A4 paper, eraser.

### ACTIVITY 11d Scale drawings LB p. 20

Individual

The following example illustrates a scale drawing. Reproduce the scale drawing showing clearly the hidden detail lines as illustrated.

#### Focus: Graphical communication

The learners learn how to draw using scale.

#### Learning activities:

- **Discussion:** Drawing to scale is a tool that engineers use for many different tasks, including designing roller coasters. One key part of every scale drawing is the scaling factor. This number represents the degree to which your scale drawing or scale model has been reduced in size when compared to the original. The learners need to maintain a constant scaling factor throughout their sketches, which will be one of the most difficult parts of the activity for them. But it is something they should strive for, as a uniform scaling factor will provide the most useful information and results. Often a scale ruler is used for this purpose.

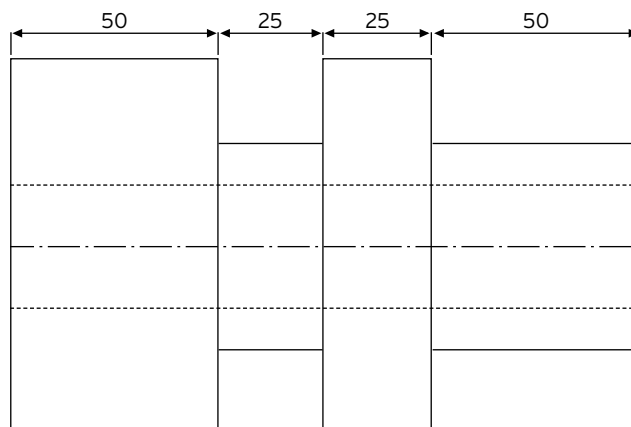

- **Written/Drawing Activity:** The learners need to draw the slide according to the scale given.
- **Extension Activity:** For homework the learners need to draw to scale 2:1 and 1:5.
- **Assessment:** Both the drawings will be assessed using the rubric provided.

Criteria	5	4	3	2	1	0	Total
1. Accuracy of drawing							
2. Makes use of scale							
3. Makes use of all relevant lines							
4. Prints neatly and accurately							
5. Dimensions the drawing correctly							
6. Demonstrates good aesthetic design							
Total							

- **Informal Educator Assessment:** You will check the completion of the tasks.

**Additional Resources:** A tracing of the drawing to check for accuracy of detail, maths sets, drawing boards, A4 paper and eraser.

Key Terms	Definition
Scale	A defined ratio of a model's size relative to the actual object that the model represents.
Ratio	Essentially a comparison between two numbers equal to one divided by the other.
Model	Simplified representation of a physical system intended to allow one to more easily analyse and understand the system.
Scale Factor	The number by which each dimension of the model is multiplied to the modelled object's actual size.

### ACTIVITY 11e Identifying line types LB p. 21

Individual

#### Case Study

The learners need to study the drawing of a bearing that you will provide. This drawing is made up of a number of lines, which tell us certain things about the drawing. The learner needs to identify each line type and say what it is used for.

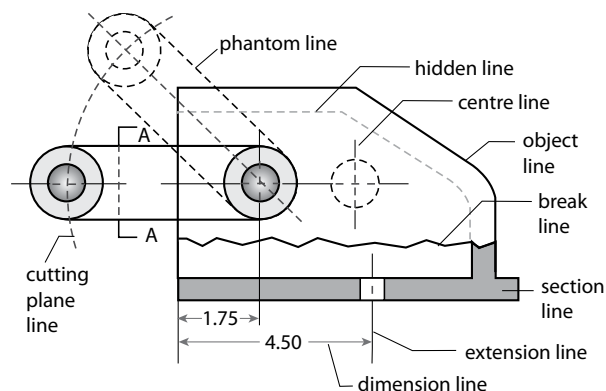

Answers to the worksheet:

- Visible outline
- Imaginary lines of intersection, dimension, projection and leader lines, hatching outlines of revolved sections

- C. Break lines to indicate the boundaries of part views and sections and irregular boundaries
- D. Hidden detail lines
- E. Centre lines, features located in front of the cutting plane, pitch circle lines, path of motion, portions to be removed
- F. Cutting planes change of direction, straight lines

### Hint

The teacher could make this into a poster. The different lines on the illustration could be made different colours which will help the learners to remember them. If A is red then the teacher can make the A on the Visual outline red. This will help learners will barriers, especially dyslexic learners sort out the information in their heads.

### Focus: Graphical communication

The learners learn about how to reproduce a drawing, and to dimension it as it is illustrated in the diagram.

#### Learning activities:

- **Discussion:** Explain to the learners the importance of dimensioning and where it is used, how it is used and why is it used. Get the learners to do some 2 dimensional drawings and to dimension them with the correct techniques.

Explain why dimensions and notes are needed on drawings. Identify, explain, and accurately use the two systems of linear measurement to dimension drawings. Describe the difference between unidirectional and aligned dimensioning. Identify and explain the three basic types of dimensions. Apply the general rules for dimensioning an inch and/or a metric drawing. Explain how to dimension circles, holes, arcs, and angles, and explain the methods used in the conversion to metric dimensioning from conventional inch dimensioning. Describe the basic principles of geometric dimensioning and tolerance. Also explain how dimensions are generated in computer-aided drafting.

- **Written/Drawing Activity:** The learners will draw the given drawing.
- **Extension Activity:** homework exercise
- **Assessment:** You will assess this activity with the rubric provided.

Accuracy	Measurements and shape correct	Mark out of 10
Outline	Outline of shape is thicker than all other lines	Mark out of 10
Dimensions	All dimensions are added in the right place and does not touch the outline of the shape	Mark out of 10
Layout	Border added, page layout well balanced, your name is written neatly	Mark out of 10

- **Informal Educator Assessment:** You will check the completion of the tasks.

**Additional Resources:** A tracing of the drawing to check for accuracy of detail, maths sets, drawing boards, A4 paper, eraser.

### ACTIVITY 11f Dimensioning diagrams LB p. 21

Individual

#### Case Study:

- The following diagram is given. The learner needs to reproduce this diagram, and dimension it as it is illustrated in the diagram. You will assess the learner's dimension skills and techniques.

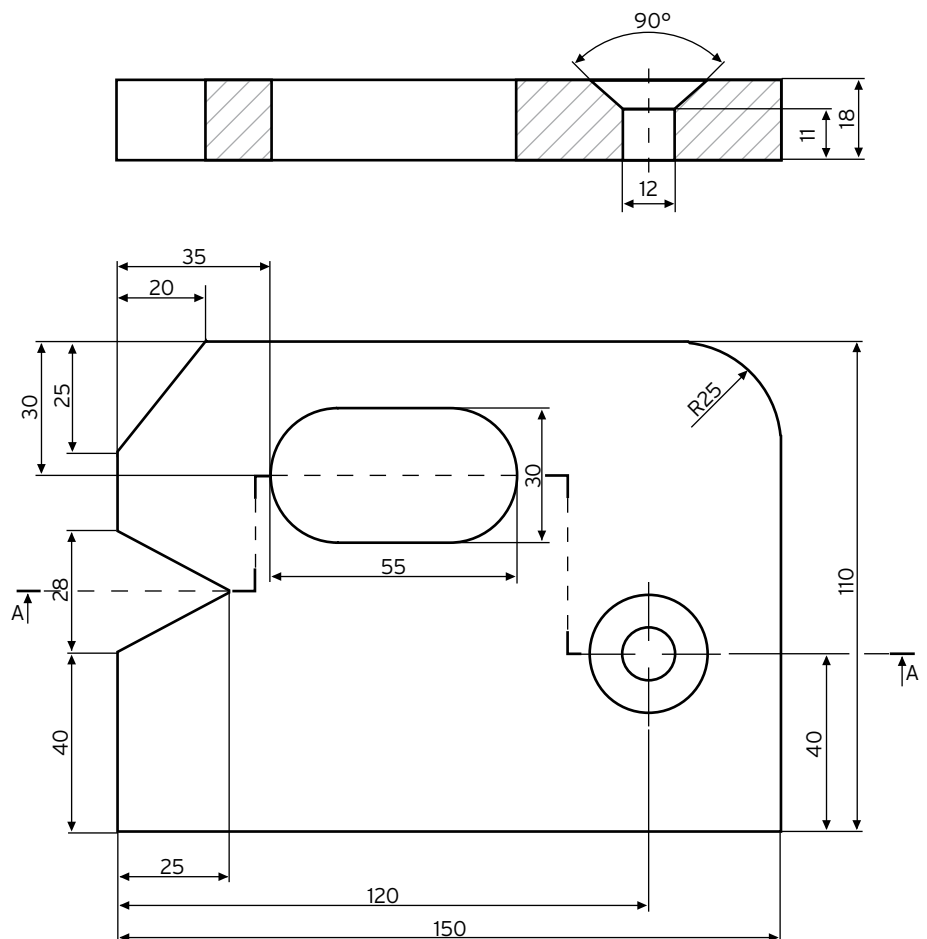
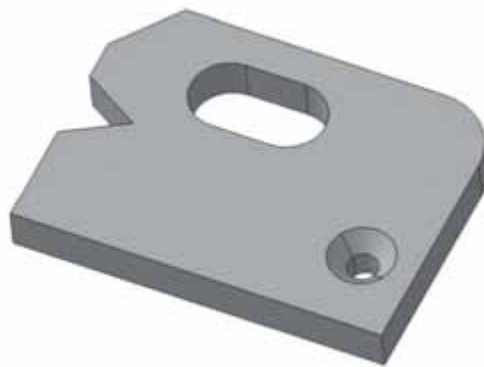

**Resources Needed:** Drawing boards, A4 paper, eraser, pencils, rulers

### Extension Activity/Homework Activity

The learners will dimension this drawing as a homework exercise.

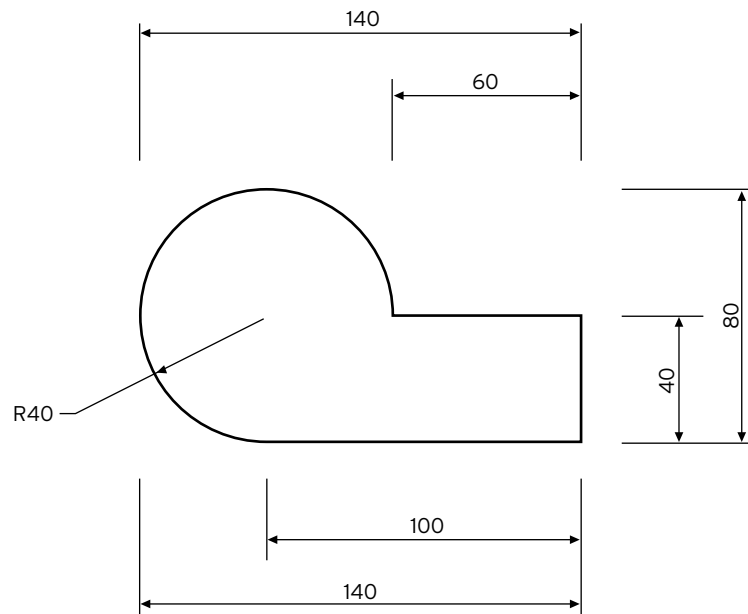

## Week 2

### Lesson 4

#### Focus: Graphical communication: sketching

The learners learn about freehand sketching.

#### Learning activities:

- **Discussion:** You need to explain to the learners that the most important thing for them is to get their ideas onto paper as quickly as possible. Sketching is therefore a very important skill for them to master. There are a few things that will help them to sketch better. To sketch quickly they need to learn to sketch from their shoulder. Most people learn to sketch on small pieces of paper, usually no bigger than A4, sketching small images. Because the images are small, people tend to learn how to sketch from the wrist. Drawing a long line tends to consist of lots of small movements from the wrist, as the arm is moved along. If the learner looks carefully at these lines they consist of lots of small arches.
- **Written/Drawing Activity:** The learners need to draw the illustration of a pair of pliers, as shown, and of the screwdriver.
- **Extension Activity:** Homework exercises given to practise this technique
- **Assessment:** Sketches will be assessed according to the rubric on page D25.

Accuracy	Measurements and shape correct	Mark out of 10
Outline	Outline of shape is thicker than all other lines	Mark out of 10
Dimensions	All dimensions are added in the right place and do not touch the outline of the shape	Mark out of 10
Layout	Border added, page layout well balanced, his or her name is written neatly	Mark out of 10

- **Informal Educator Assessment:** You will check the completed tasks for neatness and accuracy.

**Additional Resources:** Paper, pencil, eraser

## ACTIVITY 12 Drawing tools LB p. 23

Individual

### Case Study

Draw the illustration of a pair of pliers, as shown, and of the screwdriver next.



### Extension Activity/Homework Activity

Individual

#### Focus: Graphical communication: sketching

The learners need to learn about sketching.

#### Learning activities:

- **Discussion:** The learners need to continue sketching other objects for practice purposes.
- **Written/Drawing Activity:** The learners need to draw the given illustrations.
- **Informal Educator Assessment:** You will check the completion of the tasks.

## Extension activity

Individual

## Case Study

Classwork exercise

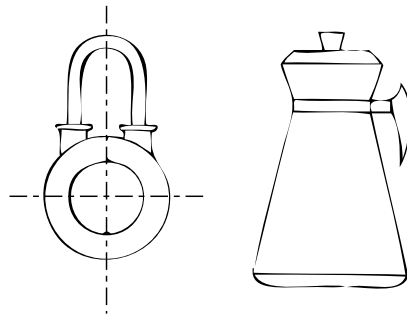
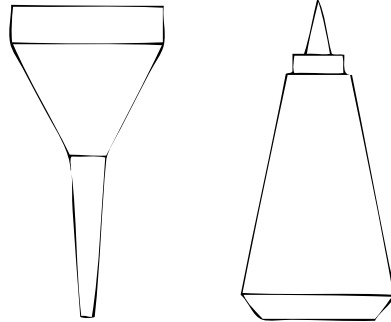

## Freehand Sketching and Shading: Sheet 1

Practise freehand sketching and shading techniques using the examples below:

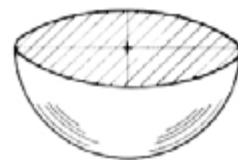
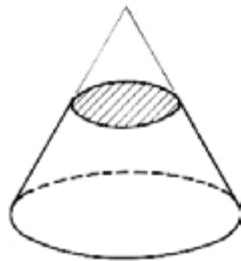
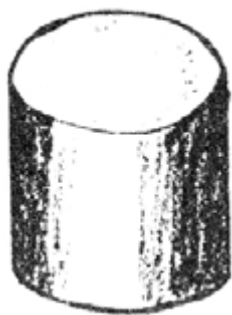
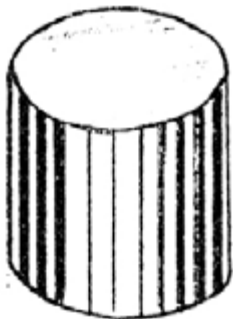
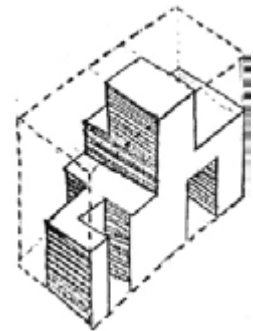
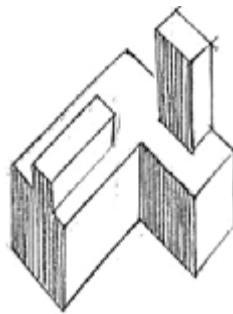
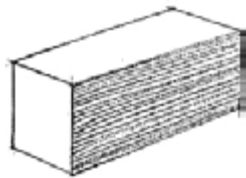
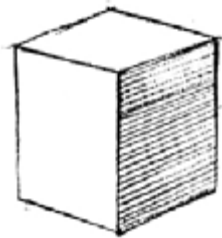

## Freehand Sketching and Shading: Sheet 2

Practise freehand sketching and shading techniques using the examples below:

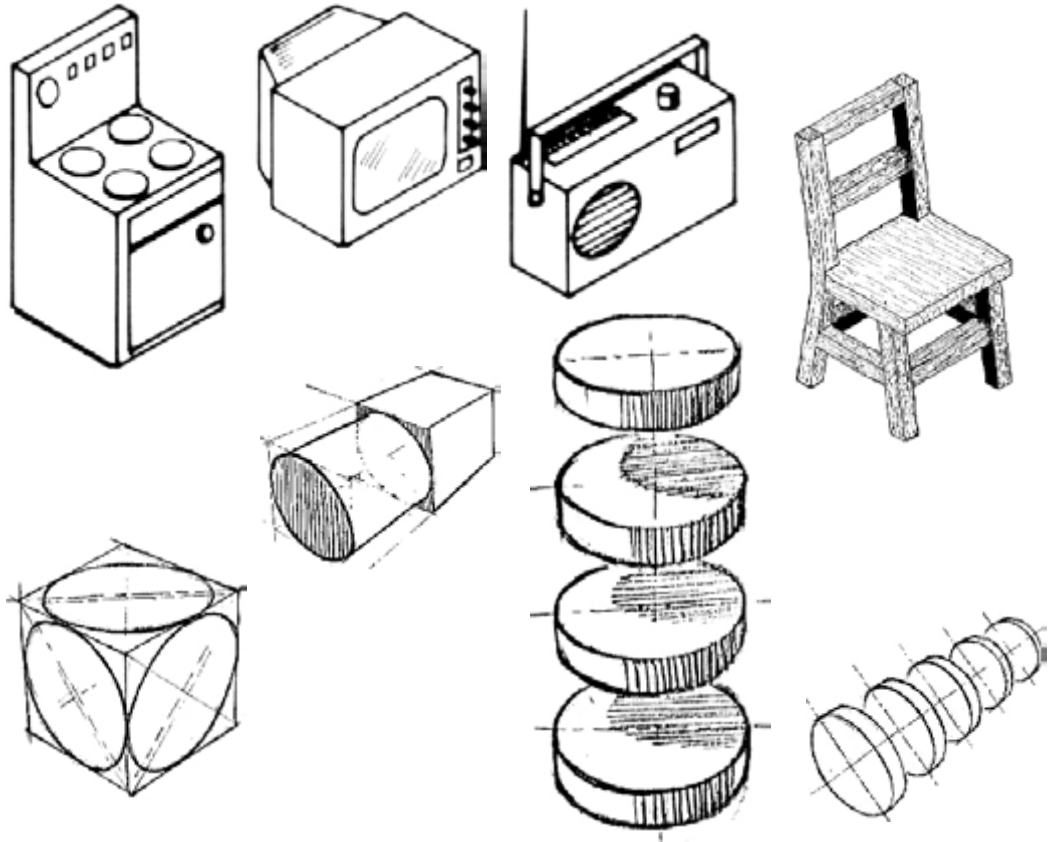

## Freehand Sketching and Shading: Sheet 3

### Homework Exercises

Practise freehand sketching and shading techniques using the examples below:

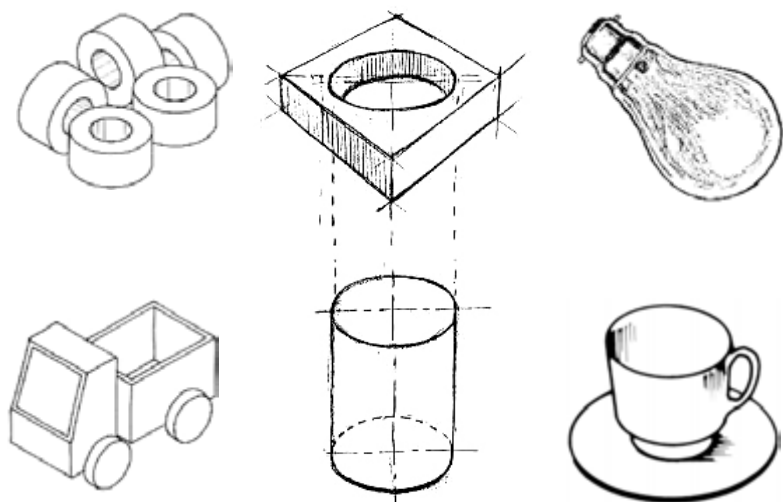



## Extension Activity/Homework Activity

Accuracy	Measurements and shape correct	Mark out of 10
Outline	Outline of shape is thicker than all other lines	Mark out of 10
Dimensions	All dimensions are added in the right place and does not touch the outline of the shape	Mark out of 10
Layout	Border added, page layout well balanced, his or her name is written neatly	Mark out of 10

### Focus: Graphical communication

The learners need to learn about developing a working drawing.

#### Learning activities:

- Discussion:** A working drawing is a complete and detailed instruction on how to develop a product from a drawing. It consists of an orthographic drawing/view, hidden details, construction details, scale, dimensions and a sequence of drawings. It also has a cutting list indicating the parts and the materials required.

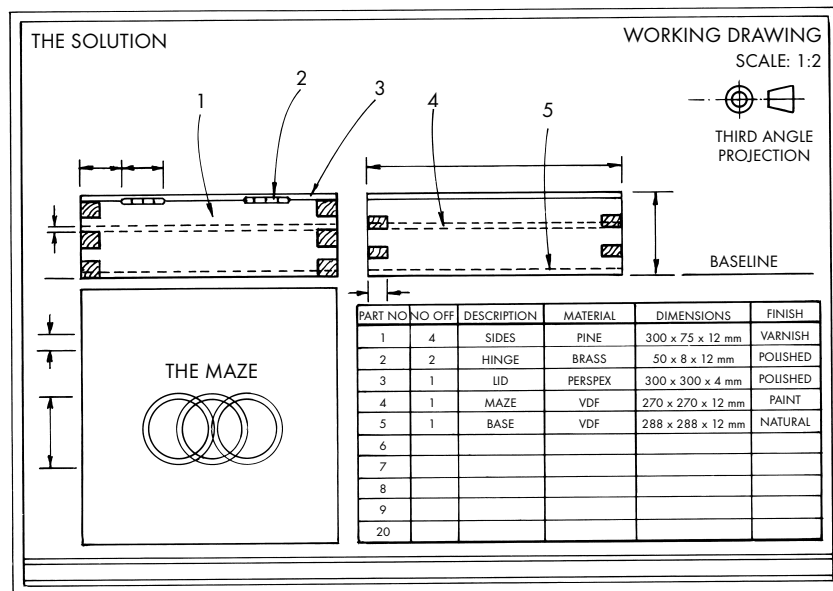

- Written/Drawing Activity:** The learners will draw a working drawing of their bookmark that shows the front, top and side view that explains all relevant dimensions, the cutting lines, and the list of materials that are required to make the project. This should be drawn in first angle orthographic projection. They should make use of all the line types about which they have learnt. They should also add dimensions to their drawing.

- **Assessment:** The rubric provided will be used to assess this activity or the working 'drawing' of the bookmark.

Accuracy	Measurements and shape correct	Mark out of 10
Outline	Outline of shape is thicker than all other lines	Mark out of 10
Dimensions	All dimensions are added in the right place and does not touch the outline of the shape	Mark out of 10
Layout	Border added, page layout well balanced, your name is written neatly	Mark out of 10

- **Informal Educator Assessment:** You will check the completion of the tasks.

### **ACTIVITY 13** A working drawing of your bookmark LB p. 25

Individual

#### **Case Study**

The learners need to develop a working drawing of their bookmark that shows the front, top and side view that explains all relevant dimensions, the cutting lines, and the list of materials that are required to make the project. This should be drawn in first angle orthographic projection. They should also make use of all the line types about which they have learnt and add dimensions to their drawing.

**Resources Needed:** A4 paper, pencil drawing sets and equipment

#### **Focus: Graphic techniques**

The learners need to learn about 3-D Oblique drawing, which depicts the front view with a depth at 45°.

#### **Learning activities:**

- **Discussion:** Read and discuss 3-D oblique drawing from the Learner's Book with the learners. Explain any words and terms they do not understand. Explain to the learners that oblique drawings can be applied to and used in the designs they will be doing later in the module. Ensure that they understand that we use the cabinet method.

#### **Example:**

The following steps can be followed to explain oblique drawings: Draw the following cabinet in oblique view. Draw the axes with the receding axis at 45°. Block in (halving the receding measurement) and draw the base. Draw the top of the enclosing block for the semi-circular part. Project the corners of this top to

the base and complete the enclosing block for the semi-circular part. Draw the centre lines for the semi-circle on the front of the enclosing block and project them on the back. Draw the semi-circle and find points of tangency T with 45° lines from the centre. Draw the 45° line from T to T. Remove excess lines and firm in the outlines, semi-circles first.

- **Written Activity:** The learners need to complete Activities 11 to 13 as set out in the Learner's Book.
- **Assessment:** The rubric provided in the Learner's Book will be used to assess this activity.
- **Informal Educator Assessment:** You will check the completion of the tasks.

**Additional Resources:** A4 paper, pencil drawing sets and equipment

## Unit 2.2 Graphic techniques

### Week 3

#### Lesson 5

The learners will learn about 3-D oblique perspective in this lesson. The front view will have a depth of 45°. Squared 'quadrant' paper will be used, and oblique projection will be used to assist with the interpretation, and with drawing single VP perspective. The 3-D artistic single vanishing point perspective will also be looked at, with colour, texture and shading.

#### **ACTIVITY 14a** Oblique drawing on grid paper LB p. 29

Individual

#### Case Study

The learner will need a pencil and squared paper to draw on. Make use of 45° squared paper (grid paper) and replicate the drawings that follow on the squared paper.

Make use of approximate dimensions, for example: A = 65mm, B = 40mm, C = 20mm and D = 25mm.

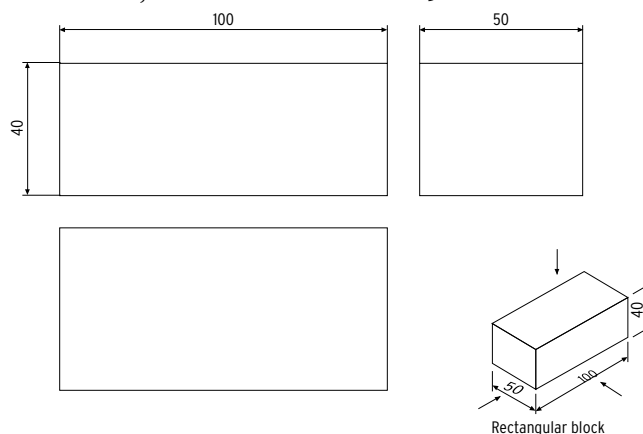

**Step 1.** Draw the oblique **axes** and enclose the box.

**Step 2.** Block in the various shapes in detail.

**Step 3.** Draw in all of the final lines with a heavy line.

Accuracy	Measurements and shape correct	Mark out of 10
Outline	Outline of shape is thicker than all other lines	Mark out of 10
Dimensions	All dimensions are added in the right place and does not touch the outline of the shape	Mark out of 10
Layout	Border added, page layout well balanced, his or her name is written neatly	Mark out of 10

**Resources Needed:** A technical drawing table (if this is not available then highlight the importance of base lines), board clips (use this only if a technical drawing table is available), compass, set squares, ruler, pencil, eraser and fine liners to highlight the outline of a shape.

### **Extension Activity/Homework Activity**

#### **Focus: Graphical communication**

The learners need to learn about 3-D oblique drawing and how to interpret an object.

#### **Learning activities:**

- **Discussion:** The learners need to complete the drawings given to them.
- **Written/Drawing Activity:** The learners need to draw oblique drawings of the three drawings given to them.
- **Assessment:** The rubric provided will be used to assess this activity.
- **Informal Educator Assessment:** You will check the completion of the tasks.

## Week 3

### Lesson 6

The learners need to learn about drawing in single point perspective.

#### Learning activities:

- **Discussion:** Read and discuss the information on pages 32 to 34 of the Learner's Book with the learners. Explain any words and terms they do not understand. Show the learners step by step how single point perspective drawings are done. Use the board or an overhead projector to demonstrate to the class. The learners can collect photographs and pictures from newspapers and magazines that illustrate perspective drawings. They can paste the pictures onto a chart which they can refer to when necessary.

The learners need to complete Activities 14 and 15 as set out in the Learner's Book. They should prepare their A4 drawing sheets as if for normal drawings. Get the learners to complete as many exercises as possible. The more practice they get, the better they will understand the concepts dealt with.

- **Written/Drawing Activity:** Make copies of the following drawings and hand them out to the learners. The learners may then copy these examples into their exercise books and add more detail.
- **Assessment:** The rubric provided will be used to assess this activity.
- **Informal Educator Assessment:** You will check the completion of the tasks.

**Additional Resources:** A technical drawing table should be used in this activity. If one is not available then the learners should highlight the importance of base lines. Other resources will include board clips if a technical drawing table is available, compass, set squares, ruler, pencil, eraser, fine liners to highlight the outline of a shape.

#### **ACTIVITY 14b** Completing oblique projection LB p. 29

Individual

#### Case Study

The learners need to complete the three shapes shown below in oblique projection. The depth of each of the drawings is 40mm. They need to make use of their own measurements that are more realistic to the sizes given in these illustrations below.

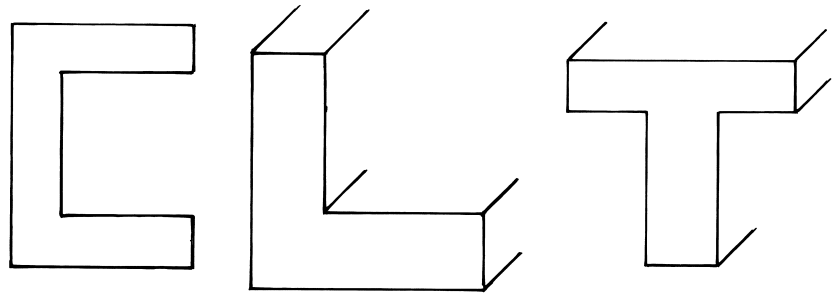

Accuracy	Measurements and shape correct	Mark out of 10
Outline	Outline of shape is thicker than all other lines	Mark out of 10
Dimensions	All dimensions are added in the right place and does not touch the outline of the shape	Mark out of 10
Layout	Border added, page layout well balanced, his or her name is written neatly	Mark out of 10

**Resources Needed:** A technical drawing table should be used in this activity. If one is not available then the learners should highlight the importance of base lines. Other resources will include board clips if a technical drawing table is available, compass, set squares, ruler, pencil, eraser, fine liners to highlight the outline of a shape.

- **Extension Activity/Homework Activity:** The learners may complete this activity at home.

### ACTIVITY 15 Single point perspective drawing LB p. 30

Individual

#### Step 1

On their drawing sheet the learners need to complete the following drawings of L-shapes and T-shapes in single point perspective:

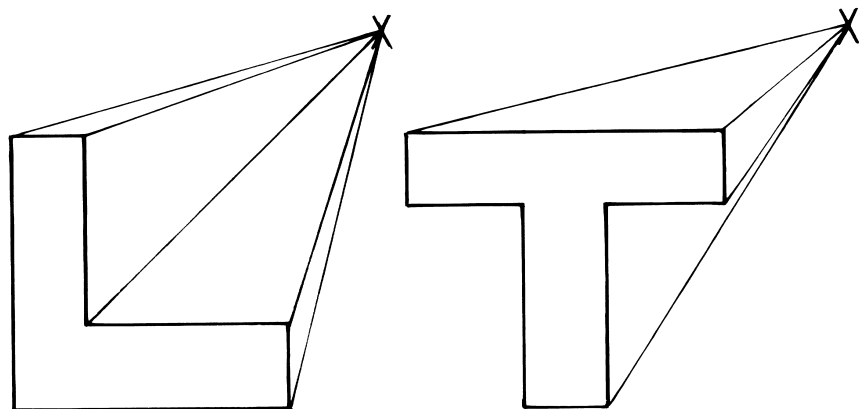

Accuracy	Measurements and shape correct	Mark out of 10
Outline	Outline of shape is thicker than all other lines	Mark out of 10
Dimensions	All dimensions are added in the right place and does not touch the outline of the shape	Mark out of 10
Layout	Border added, page layout well balanced, your name is written neatly	Mark out of 10

### Step 2

The learners need to copy the drawings in single point perspective.

Accuracy	Measurements and shape correct	Mark out of 10
Outline	Outline of shape is thicker than all other lines	Mark out of 10
Dimensions	All dimensions are added in the right place and do not touch the outline of the shape	Mark out of 10
Layout	Border added, page layout well balanced, your name is written neatly	Mark out of 10

**Extension Activity/Homework Activity:** When you think the learners understand this concept well, give them more worksheets to complete for practice.

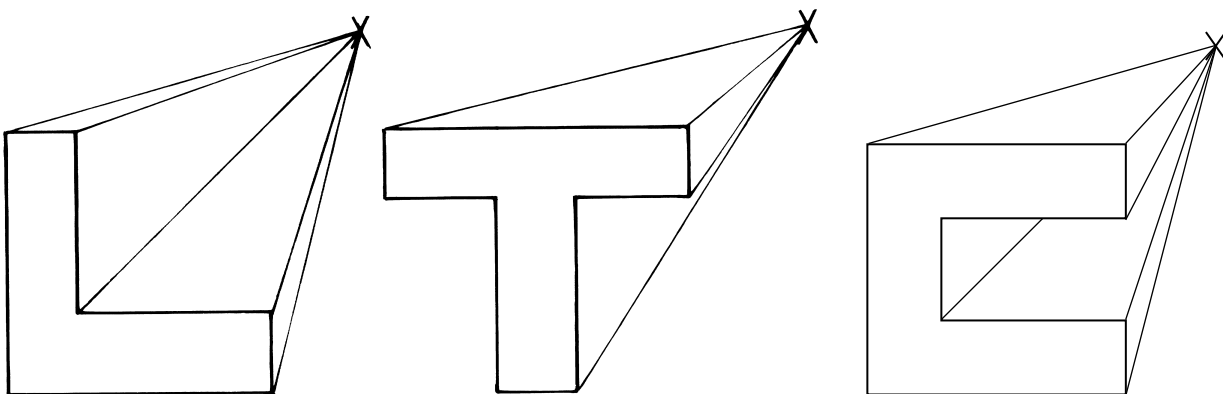

## Unit 3.1 Simple mechanisms

## Week 4

## Lesson 7

## Simple mechanisms

In this lesson the learners will study levers, and in particular mechanical advantage. They will examine the relationship between load, effort and the distance of these from the pivot. First-class levers will be looked at and their characteristics in which the fulcrum or pivot is placed between the effort and load. First-class levers will also be studied and how they may give a mechanical advantage or not, depending on pivot position. Then the case study will be done involving first-class levers with mechanical advantage:  $MA > 1$ ,  $MA = 1$ ,  $MA < 1$ .

**Focus: Simple mechanisms: Levers**

The learners will learn about levers.

**Learning activities:**

- **Discussion:** The learners need to read and understand the material in the Learner's Book.
- **Written Activity:** none
- **Extension Activity:** none
- **Assessment:** You will orally question the learner's knowledge of the lesson.
- **Informal Educator Assessment:** The learners will be questioned orally.

**Focus: Simple Mechanisms**

The learners will learn about levers in this lesson. They will study how a first-class lever works as a mechanism.

**Learning activities:**

- **Discussion:** Introduce this section by reading and discussing the information in the Learner's Book with the learners. Explain what mechanisms are, and that many of the things we use on a daily basis, such as door handles and tin openers, involve mechanisms.



Let the learners look at the pictures of mechanisms found in everyday articles in the Learner's Book and discuss these as a class.

Explain to the learners that mechanisms are used to make a job or task easier by controlling movement and force. A mechanism has an input and output.

It can change the direction in which the force acts, it can turn one kind of force into another, and it can change the place where the force acts.

- **Written Activity:** The learners need to draw and complete the table below in their exercise books.

PLACE	TYPE OF MOTION	DESCRIPTION
E.g. Wheel	Rotary motion	The wheels are moving around in a circular manner.
Pedal	Rotary	The chain and sprocket is engaged and causes the bike to move forward.
Steering	Oscillating	The bike is able to turn and change its direction of movement.
Chain and sprocket	Rotary	Moves the chain along the cog for more or less speed and torque.
Brakes	Linear	Depressing the brake handle can cause the speed of the bike to slow down and even stop.

- **Informal Educator Assessment:** You will check the completion of the tasks.

**Additional Resources:** Bring a bicycle to school.

### **ACTIVITY 16a** Types of motion LB p. 35

Individual

The learners need to draw and complete the table above in their exercise books. What is not done in class will be completed for homework.

### **Extension Activity/Homework Activity**

- **Informal Educator Assessment:** You will check the completion of the tasks.

### **ACTIVITY 16b** The usefulness of mechanisms LB p. 36

Group

The learners need to work in pairs or small groups to complete this activity. They will examine first-class, second-class and third-class levers in pairs and groups. Let the pairs or groups share their answers with the rest of the class. Listen to their responses and give feedback where necessary.

### **Mechanisms make your life easier**

1. The learners need to look at the pictures in their books and discuss in their group which mechanism they will use to do the work in the row of pictures.

### **Work to be done**

2. Mechanism to do the work:  
bottle opener      lifting a box      screwdriver
3. The learners need to explain how the tool makes the task to be done easier
  - The bottle opener acts as a second-class lever and opens the cap on a bottle.
  - The woman lifts the box and her knees act as a third-class lever.
  - The screwdriver acts as a first-class lever and can pry open a can of paint.

**Resources Needed:** A worksheet

### **Focus:**

The learners need to learn about levers and about the positions of the load, effort and fulcrum.

### **Learning activities:**

- **Informal Educator Assessment:** You will check the completion of the tasks.

## **ACTIVITY 17** How a lever system works LB p. 38

Group

In small groups, the learners need to look at the illustration of a basic example of a lever system (a seesaw) and identify the place where each of these three words will fit: **effort**, **pivot** (or **fulcrum**), and **load**. They need to state the mechanical advantage in this illustration.

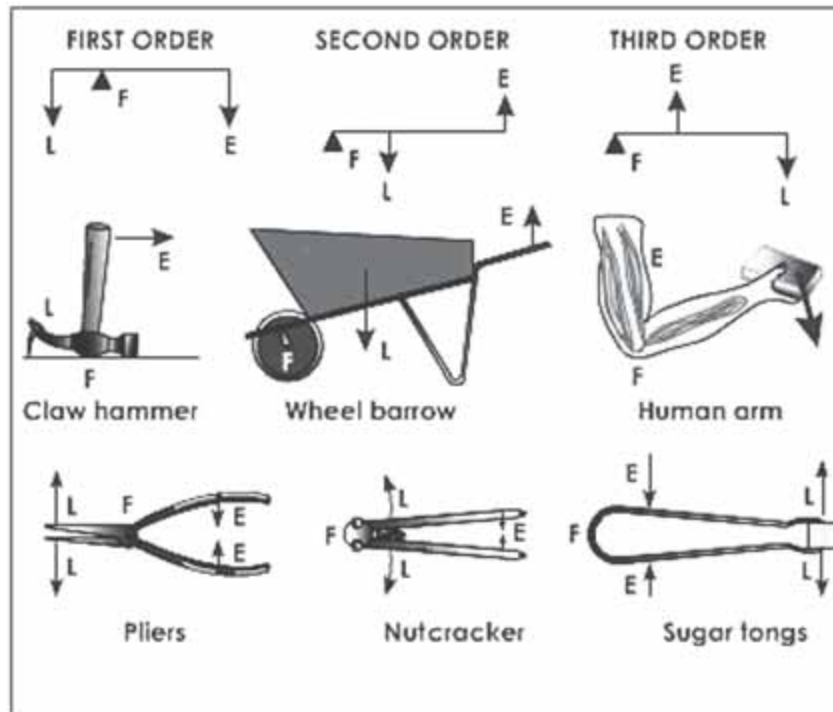

LOAD

FULCRUM

EFFORT

**Resources Needed:** A model of a seesaw

## Week 4

### Lesson 8

The learners will learn about first-class levers.

#### Learning activities:

- **Discussion:** The learners can work in pairs or small groups to complete this activity. They will examine first-class, second-class and third-class levers in pairs and groups. Let the pairs or groups share their answers with the rest of the class. Listen to their responses and give feedback where necessary.
- **Written Activity:** The learners need to record their answers.
- **Assessment:** You need to mark the answers of the learners.
- **Informal Educator Assessment:** You will check the completion of the tasks.

**Additional Resources:** You should draw a table on the board for the learners to copy into their exercise books.

#### ACTIVITY 18 Investigate first-class levers LB p. 40

Individual

#### Case Study

List any other three examples of first-class levers from the one given in the Learner's Book that satisfy each of these criteria: mechanical advantage:  $MA = 1$ ;  $MA < 1$ ;  $MA > 1$ .

MECHANICAL ADVANTAGE	MECHANISMS		
MA = 1	Seesaw	Tongs	Bottle opener
MA < 1	Scissors	Crowbar	
MA > 1	Pliers	Screwdriver	Tinsnips

### ACTIVITY 19 Examples of first-class levers LB p. 41

Group

#### Case Study: Reading for meaning and understanding

The learners should bring examples of first-class levers to class. You should send a letter home with the learners about that. If they cannot bring examples then they should find some in books and magazines. During the lesson on the discussion of first-class levers, divide the learners into groups. Present each group with an example of a lever and ask them to explain where the load, effort and fulcrum are in relation to a first-class lever.

## Week 5

### Lesson 9

In this lesson second-class levers will be examined and their characteristics, in which the load is placed between the effort and fulcrum. Real examples will be given of second-class levers. The learners will demonstrate second-class levers, which always give a mechanical advantage, with models. Following this, third-class levers will be looked at and their characteristics in which effort is placed between the load and fulcrum. Again, real examples will be given of these, and the learners will demonstrate models of third-class levers, which will never give a mechanical advantage.

### ACTIVITY 20 Examples of second-class levers LB p. 42

Class and Group

#### Case Study

The learners should bring and draw examples of second-class levers to class. During the lesson on the discussion of first-class levers and second-class levers divide the learners into groups. Present each group with an example of a lever and ask them to explain where the load, effort and fulcrum are in relation to first-class levers and second-class levers.

**Resources Needed:** You should provide examples of first-class levers and second-class levers.

- **Extension Activity/Homework Activity:** The learners will complete the activity at home.

#### Focus:

The learners will learn about drawing a systems diagram to illustrate each position of the load, effort and fulcrum for levers.

### Learning activities:

- **Discussion:** Indicate to the learners the position of the load, effort and fulcrum in each of the classes of levers and also show them how to draw the systems diagram for each example.

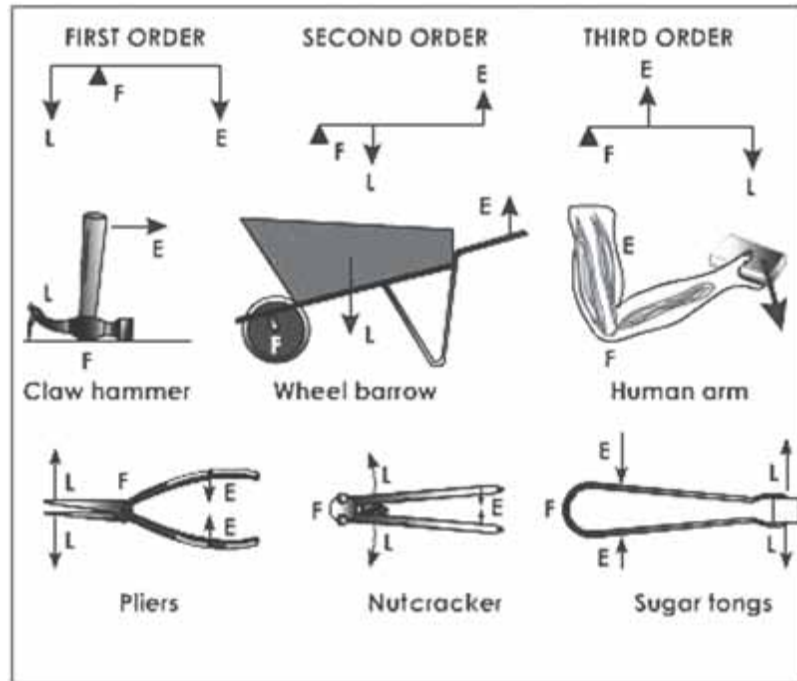

- **Written Activity:** The learners need to draw the systems diagram of each class of lever in each example.
- **Assessment:** You need to assess the learners' answers.
- **Informal Educator Assessment:** You will check the completion of the tasks, and the correction of tasks.

**Additional Resources:** You should provide different examples of levers (classes).

### ACTIVITY 21 Drawing a systems diagram LB p. 43

Individual

#### Case Study

The learners need to draw a systems diagram to illustrate each position of the load, effort and fulcrum for each of the examples given above.

## Week 5

### Lesson 10

#### Focus: Simple mechanisms

The learners will learn about third-class levers.

### Learning activities:

- **Discussion:** You will discuss third-class levers.
- **Written Activity:** calculate mechanical advantage and draw a systems diagram of each example.
- **Assessment:** You need to assess the learners' answers and drawings.

- **Informal Educator Assessment:** You will check the completion of the tasks.

**Additional Resources:** You should provide examples of third-class levers and charts.

## **ACTIVITY 22** Examples of each class of lever LB p. 44

Individual

### **Focus:**

The learners need to learn about all three classes of lever.

### **Learning activities:**

- **Discussion:** During the lesson on the discussion of first-class levers and second-class levers divide the learners into groups. Present each group with an example of a lever and ask them to explain where the load, effort and fulcrum are in relation to first-class levers and second-class levers.
- **Written Activity:** The learners need to use a table to record their answers:

Example	First-class	Second-class

- **Assessment:** You need to check the answers for accuracy and relevancy.
- **Informal Educator Assessment:** You will check the completion of the tasks.

**Additional Resources:** You should provide examples of first-class levers, second-class levers and third-class levers.

### **Case Study**

Each learner must bring an example of each of the three classes of lever and investigate how each operates according to the principle of mechanical advantage. The learner must also identify the position of the load, effort and fulcrum in each of the examples investigated. They should draw systems diagrams of each third-class lever brought to class, and label the position of the load, effort and fulcrum on the diagram.

**Resources Needed:** You should provide examples of third-class levers and charts.

## **Week 6**

### **Lesson 11 and 12**

In this lesson a practical investigation will be done on levers and linkages. Simple linked first-class levers will be examined, such as a pair of scissors, pair of pliers and hedge-trimming shears. Simple linked second-class levers will also be examined, such as an office punch and nutcrackers. Simple linked third-class levers will be examined, such as most office

staplers and a pair of tweezers. Also, more complex linkages will be examined, such as linkages with more than one pivot.

**Focus: Simple mechanisms levers and linkages**

The learners will learn about first-class levers and the positioning of the load, effort and fulcrum.

**Learning activities:**

- **Discussion:** You will discuss first-class levers with the learners.
- **Written Activity:** The learners will complete a table.
- **Assessment:** You will assess the completed tables.
- **Informal Educator Assessment:** You will check the completion of the tasks and correction of work.

**Additional Resources:** You should provide examples of first-class levers and charts.

**ACTIVITY 23** Linked first-class lever LB p. 44

Individual

**Case Study**

Examine linked first-class lever, such as a pair of scissors, a pair of pliers and hedge-trimming shears.

First-class lever	A pair of scissors	A pair of pliers	Hedge-trimming shears
Characteristics			
Diagram			

**Resources needed:** You should provide examples of first-class levers and charts. The following photos can be made into posters for these activities.

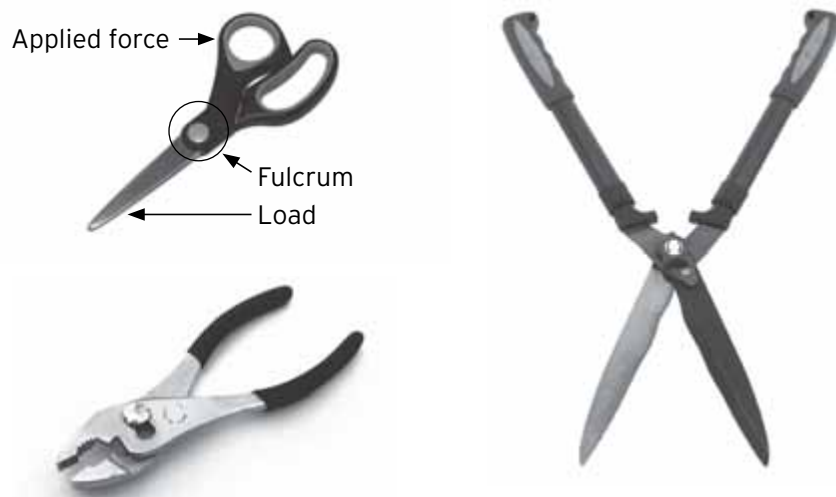

- **Extension Activity/Homework Activity:** The learners may complete this task at home.

## Focus: Simple mechanisms levers and linkages

The learners will learn about second-class levers.

### Learning activities:

- **Discussion:** You will hold a discussion on second-class levers with the learners.
- **Written Activity:** The learners need to complete the table.
- **Assessment:** You will need to assess the completed table.
- **Informal Educator Assessment:** You will check the completion of the tasks and the correction of work.

**Additional Resources:** You will need to provide examples of second-class levers.

### ACTIVITY 24 Linked second-class levers LB p. 44

Individual

Examine linked second-class levers (Such as an office punch, a bicycle brake calliper, and a nutcracker.).

Second-class lever	An office punch	A bicycle brake calliper	A nutcracker
Characteristics			
Diagram			

**Resources Needed:** You will need to provide examples of second-class levers and a chart.

- **Extension Activity/Homework Activity:** The learners will complete the task at home.



## Focus: Simple mechanisms levers and linkages

The learners will learn about third-class levers.

### Learning activities:

- **Discussion:** You will discuss third-class levers with the learners.
- **Written Activity:** The learners will complete a table.
- **Assessment:** You will assess the learners' tables.
- **Informal Educator Assessment:** You will check the completion of the tasks and correction of tasks.

**Additional Resources:** You will need to provide examples of third-class levers and a chart.



## ACTIVITY 25 Extension activity LB p. 44

Individual

Examine linked third-class levers (Such as an office stapler, a pair of tweezers and a human arm).

Third-class lever	An office stapler	A pair of tweezers	A human arm
Characteristics			
Diagram			

**Resources Needed:** You will need to provide examples of third-class levers and a chart.



- **Extension Activity/Homework Activity:** The learners will complete the task at home.

## Informal assessment task

### Week 7

### Lesson 13

In this lesson you must explain the informal assessment task to the class. This will involve the impact of technology with the scenario where emergency workers use of the Jaws-of-life system to rescue trapped accident victims. For this, the use of pneumatics and hydraulics to enhance human strength will be looked at. The learners will do practical investigations in which there will be force transfer between two equal syringes filled with 1. air and 2. water. Following this the force transfer between two unequal syringes will be examined, filled with 1. air and 2. water.

### Focus: Mechanical systems and control

The learners will learn about hydraulics and pneumatics.

### Learning activities:

- **Discussion:** You will discuss pneumatics and hydraulics with the learners.
- **Written Activity:** The learners will record their ideas on the enhancement of human strength using mechanisms.
- **Extension Activity:** The learners may research this topic on the Internet.
- **Assessment:** The learners will do an oral presentation of their ideas for this lesson.
- **Informal Educator Assessment:** You will check the completion of the tasks.

**Additional Resources:** You may provide a DVD on extreme machines or an excursion to the fire department to watch a demonstration on the use of the Jaws-of-life.

## ACTIVITY 26 The uses of pneumatic systems LB p. 49

Group

The learners need to indicate in what ways and with what equipment pneumatics and hydraulics can be used to enhance human strength. They should record some of their thoughts and ideas in their exercise books, and then discuss this in front of the class in groups.

**Resources Needed:** The learners could use the Internet, books and pictures to study this section further.

- **Extension Activity/Homework Activity:** The learners could research on the internet or in libraries for more information on this topic.

### Focus: Mechanical systems and control

The learners will learn about mechanical systems and control.

### Learning activities:

- **Discussion:** Read and discuss the information on pages 47 to 57 of the Learner's Book with the learners. Make sure they understand all the words and terms. To demonstrate the power of air and how pneumatic systems work, conduct this simple experiment in the class. Put a balloon underneath a book. The open end of the balloon should stick out. Ask one of the learners to blow air into the balloon. The learners can then watch how the air (pneumatic power) lifts the book. This demonstrates systems and control and mechanical systems.
  - Ask the learners to bring pictures to class of anything that uses pneumatics. Examples include drills, diggers, tipper trucks, dental drills and bus or train doors.
  - Put the pictures up in the classroom while this section is discussed.
  - Explain to the learners how pneumatics is used in everyday lives to solve problems.

- The learners must come up with some ideas of how they can make use of pneumatics in their designs.
- **Written Activity:** The learners need to answer questions and record their observations.
- **Assessment:** You will assess the learners based on their orals and assessment worksheets.
- **Informal Educator Assessment:** You will check the completion of the tasks.

**Additional Resources:** You need to provide two syringes of equal size, and plastic tubing.

## **ACTIVITY 27** Investigating pneumatic systems LB p. 49

Group

Work in small groups and take the following steps to investigate **pneumatic** and **hydraulic** systems.

**What the learners will need:**

Two syringes of equal size and plastic tubing.

Method:

- The learners need to push the plastic tube over the tip of one syringe with the plunger down.
- Pull the plunger out of the other syringe and connect the other end of the plastic tube to the tip of this syringe.
- Push the plunger into the syringe and observe what happens. The learners should record their answers in their exercise books.
- The learners need to pull the plunger out of the second syringe and fill this syringe with water. They should make sure that there are no air bubbles. Push the plunger in and observe what happens.
- The learners need to follow the same process with different sized syringes. They should observe and record what happens in their exercise books. They need to discuss, with a partner, what they have learnt in the process.

The learners need to answer the following questions in their groups, and record their answers in their exercise book.

- a. Which works best, the syringe filled with air or the syringe filled with water? Give reasons for your answer. The water or hydraulic system works best, because water cannot be compressed, hence force distribution is equal in all areas.
- b. What happens when you use syringes of different sizes? With a hydraulic system with a small syringe and a large syringe, when you press the plunger on the small syringe, the surface area of the plunger (of the small syringe) is less than the big plunger of the big syringe. Therefore the small syringe can only push a small amount of water, but it is easier to push. The large syringe's plunger will move less. It has greater mechanical advantage, but less movement.

- c. Which output force is the greatest, the one with the small syringe or the one with the big syringe? Give reasons for your answer. When you press the large syringe in this system, it is more difficult to press as you are moving a large amount of water, but the small syringe's plunger moves more. There is less mechanical advantage, but the syringe moves more.

**Resources Needed:** You will need to provide equal sized syringes to the learners.

- **Extension Activity/Homework Activity:** The learners will complete the worksheet at home.

### **Focus: Mechanical systems and control**

The learners will learn about hydraulics and pneumatics.

### **Learning activities:**

- **Discussion:** You will discuss hydraulic and pneumatics with the learners.
- **Written Activity:** The learners will write down their observations from the experiments.
- **Assessment:** You will assess the learners based on their oral responses to questions on the experiment and their findings.
- **Informal Educator Assessment:** You will check the completion of the tasks and correction of the tasks.

**Additional Resources:** You need to provide two equal syringes and tubing for the learners.

## **Week 7**

### **Lesson 14**

#### **ACTIVITY 28a Building a pneumatic system** LB p. 51

Individual

#### **Build a simple model of a pneumatic system**

Investigation: Force transfer between two equal syringes filled with:

1. air
2. water.

The learners need to connect two identical syringes together with a piece of plastic tubing. Before connecting the tubing they need to make sure that the plunger on one syringe is pulled back all the way while the plunger of the other syringe is completely pushed into the syringe.

The purpose of these investigations is to examine the functioning of a pneumatic system and to compare it with that of a hydraulic system.

The learners need to dry the plastic syringes and repeat the investigation performed in Activity 25. This time they should draw up air into the cylinders instead of water.

1. What similarities exist between hydraulic and pneumatic systems?  
Both of these systems use pressure to perform work. Hydraulics uses liquids, which cannot be compressed, to exert pressure while pneumatics uses gasses which are compressed to exert pressure.
2. What difference is there between the systems with regard to the effective transmission of the pressure?

**Pneumatic Systems:** These systems have two main features:

- a) Pneumatic systems use compressed gas such as air or nitrogen to perform work processes.
- b) Pneumatic systems are open systems, which exhaust the compressed air into the atmosphere after use.

**Hydraulic Systems:** These systems also have two main features:

- a) Hydraulic systems use liquids such as oil and water to perform work processes.
- b) Hydraulic systems are closed systems, which recirculate the oil or water after use.

One of the main differences between these two systems is that in pneumatics, air is compressible, whereas in hydraulics, liquids are not.

**What are the advantages of pneumatics?**

In pneumatics, a system needs only one power source. The work process creates a lower noise level than hydraulic systems, and pneumatic systems are relatively clean and can operate at high speed. Pneumatic systems also feature lower component costs.

**Resources Needed:** The learners need two equal syringes and tubing for this experiment.

**Focus: Mechanical systems and control**

The learners will learn about hydraulics and pneumatics.

**Learning activities:**

- **Discussion:** You will discuss hydraulic and pneumatics with the learners.
- **Written Activity:** The learners need to make the following observations from the experiments:

### **ACTIVITY 28b** Investigating transfer between syringes LB p. 53

Individual

In this activity, the learners will investigate the force transfer between two **unequal syringes** filled with:

1. air
2. water.

1. They will need two sets of unequal syringes, plastic tubing and a liquid (oil or water) to set up this experiment.

## Focus: Mechanical systems and control

The learners will learn about making a hydraulic and pneumatics mechanism.

### Learning activities:

- **Discussion:** You will discuss hydraulic and pneumatics with the learners. They will design and make a hydraulic or pneumatic mechanism that is similar to a Jaws-of-life.
- **Written/Drawing Activity:** The learners need to provide a drawing of the model to be made, and a description of how the model is to be made.
- **Assessment:** You will assess the learners based on their responses to oral questions on designing and making process, assessment of the design and assessment of the model according to a set of criteria.
- **Informal Educator Assessment:** You will check the completion of the tasks and the correction of the tasks.

**Additional Resources:** You need to provide maths sets, A4 paper, cardboard, syringes, tubing, utility knife and scissors for the learners.

### Word list:

large, bigger, master, small, slave, large, piston

2. a. A small force on the small 1) master syringe results in a 2) bigger force on the 3) large slave syringe. You have to move the master 4) piston a 5) large distance to have this effect. At the same time, the 6) large syringe will only move a 7) small amount.

When the large syringe **G** acts as the **master** and the small syringe **S** acts as the **slave**.

### Word list:

driving, further, large, force, distance, force

2. b. A 1) large force over a small 2) distance in G is reduced to a smaller 3) force on S. The piston in S will move much 4) further than that in G. It is also noted that there will be a 5) large change if the small syringe is 6) driving the larger one.

What did they notice about the speed of the pistons: That they move at a slow pace.

You will give the learners a worksheet to complete.

- **Assessment:** You will assess the learners based on their responses to oral questions on the experiment and their findings.
- **Informal Educator Assessment:** You will check the completion of the tasks and the correctness of the tasks.

**Additional Resources:** You need to provide two unequal syringes and tubing for the learners.

## Week 8

### Lesson 15

#### **ACTIVITY 29** A working model of a rescue device LB p. 54

Group

- **Design and make:** The learners need to work in teams to develop a working model of a hydraulic-syringe powered, linked-lever rescue device using simple materials.

**Resources Needed:** You will need to provide A4 paper, cardboard, syringes, tubing, utility knife and scissors to the learners.

#### **Focus: Mechanical systems: Writing a design brief**

The learners will learn about how to write a proper design brief.

#### **Learning activities:**

- **Discussion:** You will discuss design brief requirements with the learners.
- **Written Activity:** The learners need to write the design brief, stating the specifications and limitations.
- **Assessment:** You will need to assess the learners' design briefs.
- **Informal Educator Assessment:** You will check the completion of the tasks.

#### **ACTIVITY 30** Developing your design brief LB p. 54

Individual

The learners need to state clearly what their design brief is, and what specifications and constraints are required in their building of this project.

**Resources Needed:** Learner's Book

#### **Focus: Mechanical systems: Oblique drawing**

The learners will learn how to draw the model they are going to make in 3-D oblique projection.

#### **Learning activities:**

- **Discussion:** You will discuss how to draw oblique projection with the learners.
- **Written/Drawing Activity:** The learners will draw the model in 3-D oblique projection.
- **Assessment:** Assess the learners' drawings according to the drawing rubric on page 27 of the Learner's Book.
- **Informal Educator Assessment:** You will check the completion of the tasks.

## Week 8

### Lesson 16

#### **ACTIVITY 31** 3-D drawing in oblique projection LB p. 55

Individual

In order to communicate their idea to the rest of their class the learners need to create a 3-D drawing of the idea in oblique projection using dark (visible outlines) and faint lines (construction lines).

**Resources Needed:** You need to provide A4 drawing paper, maths sets and pencils.

- **Extension Activity/Homework Activity:** The learners will complete the drawing at home.

#### **Focus: Mechanical systems: Single point perspective drawing**

The learners will learn about drawing in single point perspective.

#### **Learning activities:**

- **Discussion:** You will discuss single point perspective with the learners.
- **Written/Drawing Activity:** The learners need to draw their model in single point perspective using colour, texture and shading.
- **Extension Activity:** The learners should look at books for ideas.
- **Assessment:** You need to assess the completed drawings of the learners.
- **Informal Educator Assessment:** You will check the completion of the tasks and the correctness of the drawing.

**Additional Resources:** You need to provide A4 drawing paper, maths sets and pencils for the learners.

#### **ACTIVITY 32** Sketch in single VP perspective LB p. 55

Individual

The learners need to demonstrate their expertise in being able to sketch in single VP perspective. This should be enhanced with the use of two of colours, texture or shading.

**Resources Needed:** You need to provide A4 drawing paper, maths sets and pencils.

- **Extension Activity/Homework Activity:** The learners will complete the drawing at home.

#### **Focus: Mechanical systems: Orthographic projection**





The learners will learn about orthographic projection with dimensioning.



**Learning activities:**

- **Discussion:** You will discuss how to draw a model in orthographic projection with the learners.

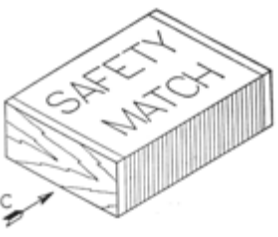
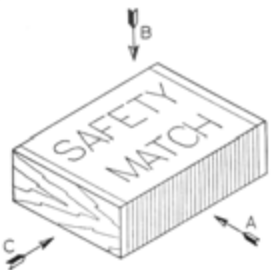
**ORTHOGRAPHIC PROJECTION**

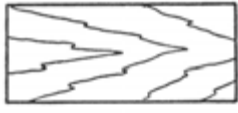
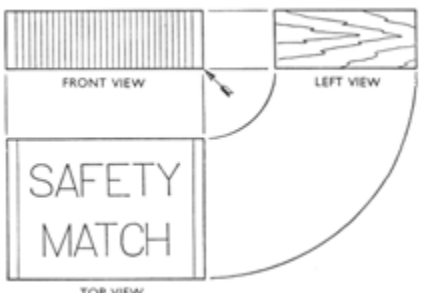
 <p>1. A matchbox is given as an example to demonstrate orthographic projection. Remember that the matchbox does not move but we move around the matchbox to get the different views.</p>	 <p>3. When we look at the matchbox we look at it in the direction of Arrow A, which represents the front view.</p>	 <p>5. Arrow B shows us looking at the match box from the top view.</p>	 <p>7. Arrow C shows us the left view of the match box.</p>
 <p>2. When we look at the match box we look at it in three directions, from the front = arrow A, from the top = arrow B, and from the side or left = arrow C.</p>	 <p>4. This is what the front view will look like if we look at it at right angles. All the measurements are true lengths.</p>	 <p>6. This is what the matchbox will look like from the top looking at it at right angles.</p>	 <p>8. This is what the matchbox looks like from the side view/ or left view.</p>
 <p>This is what the completed drawing in orthographic projection will look like.</p>			

- **Written/Drawing Activity:** The learner needs to draw an orthographic projection of the model.

- **Extension Activity:** You will need to provide examples of orthographic projection for the learners.
- **Assessment:** You will need to assess the learners' drawings of the model in orthographic projection.
- **Informal Educator Assessment:** You will check the completion of the tasks and the correctness of the drawing.

**Additional Resources:** You need to provide A4 drawing paper, maths sets and pencils for the learners.

### **ACTIVITY 33** 2-D working drawing LB p. 55

Individual

The learners are also expected to develop a working drawing in 2D which will show one view with dimensions to scale.

**Resources Needed:** Materials for the models.

#### **Extension Activity/Homework Activity**

##### **Focus: Mechanical systems**

The learners will learn about how to make models.

##### **Learning activities:**

- **Discussion:** You will discuss model building and safe working techniques with the learners.
- **Written/making Activity:** The learners need to make their models.
- **Assessment:** You will need to assess the learners' models.
- **Informal Educator Assessment:** You will check the completion of the tasks.

**Additional Resources:** You need to provide tools and equipment needed for the learners to build the model.

## **Week 9**

### **Task**

The learners need to make a simple working model.

At a minimum, the Jaws-of-life model may be a simple device representing how any one machine in the Jaws-of-life system (or part) will work using plastic tubing, syringes and cardboard.

**Resources Needed:** You will need to provide the learners with tools and equipment needed to build their models, plastic tubing, syringes and cardboard.

- **Extension Activity/Homework Activity:** The learners will complete the project at home.

## Week 10

### Task continued from Week 9

#### Formal Assessment Task - Test

1. Briefly, explain what Technology is. (3)
2. Draw a cyclic representation to explain the design process and briefly explain each step. (10)
3. What do you understand by the terms.
  - a. ergonomics
  - b. aesthetics? (2)
4. Using only a pencil and eraser, copy the following picture freehand onto the grid provided. Insert at least three important dimensions. (6)

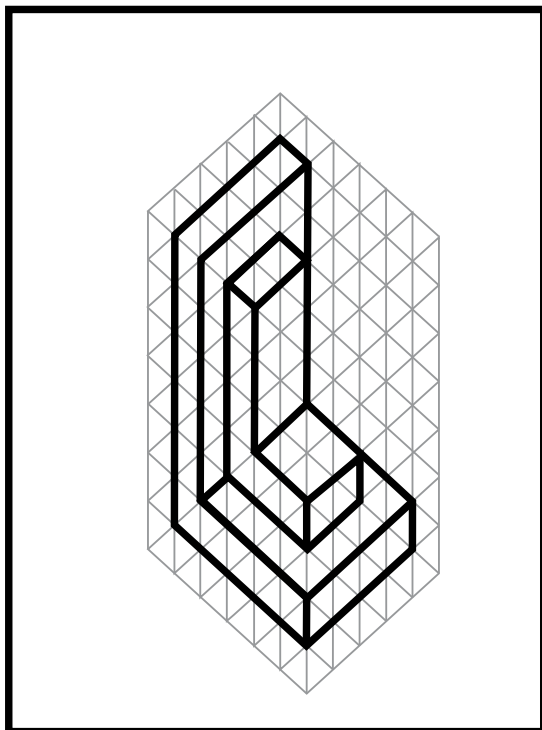
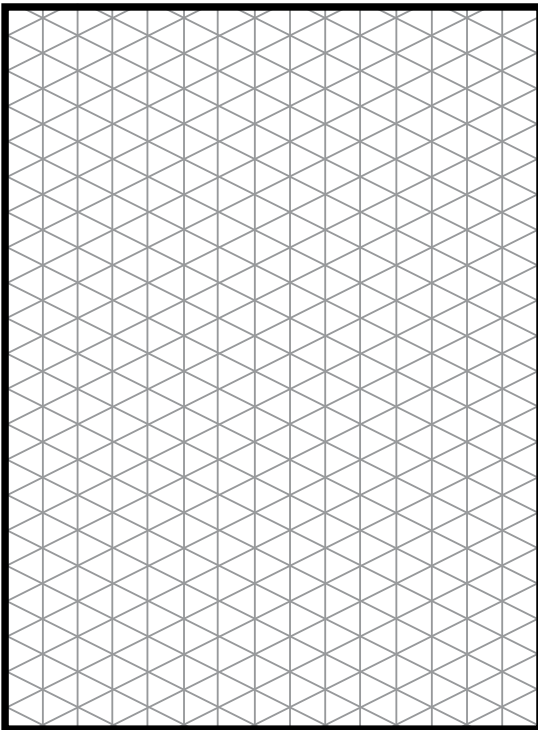

5. Redraw the following diagram as accurately as possible. Use measurements given in millimetres. (8)

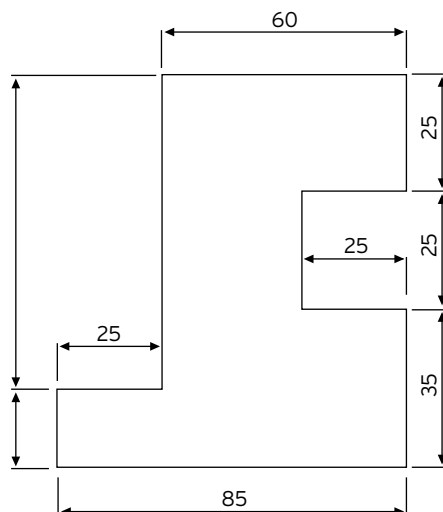

6. Identify the six types of lines shown in the illustration below. (6)

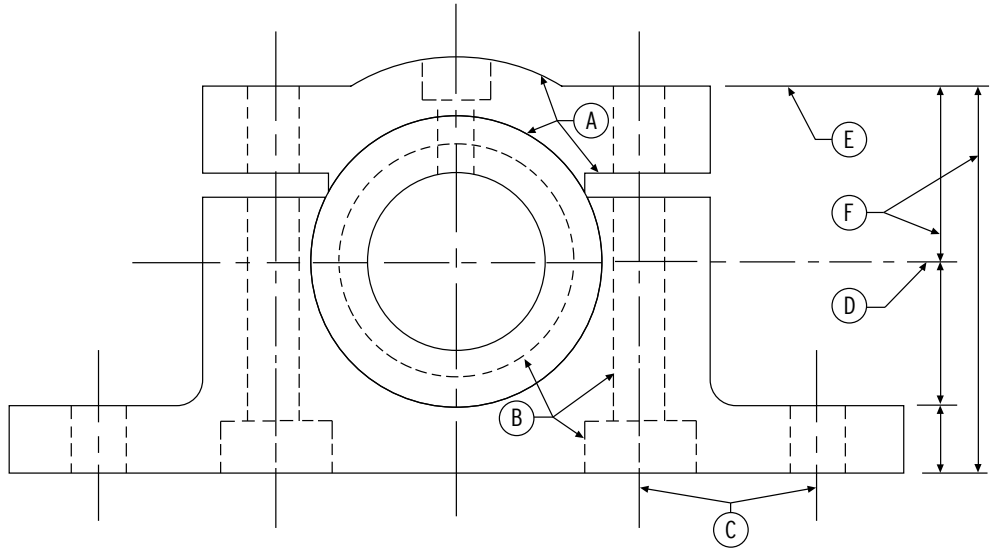

7. Draw the following drawing in oblique drawing, making use of the following measurements. Make use of approximate dimensions, for example: A=65mm, B =40mm, C=20mm, D=25mm. (10)

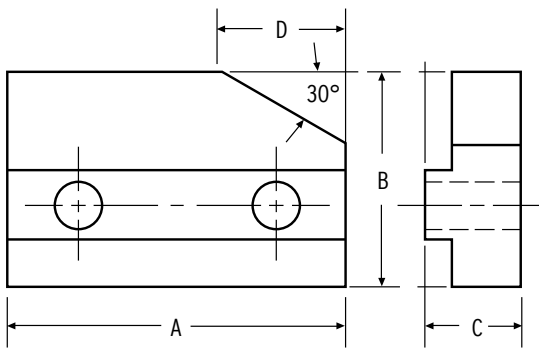

(a) GIVEN VIEWS

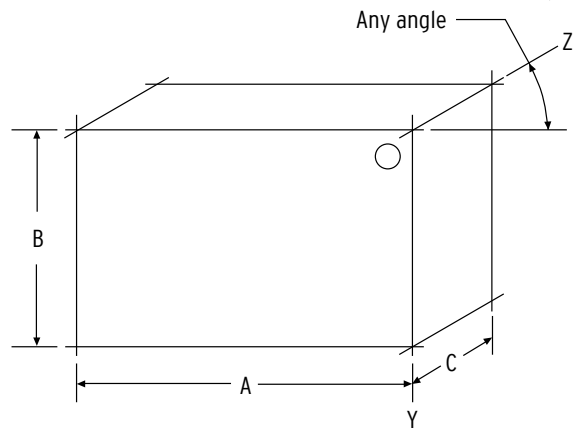

8. Redraw the following illustration of a room using single point perspective techniques. (10)

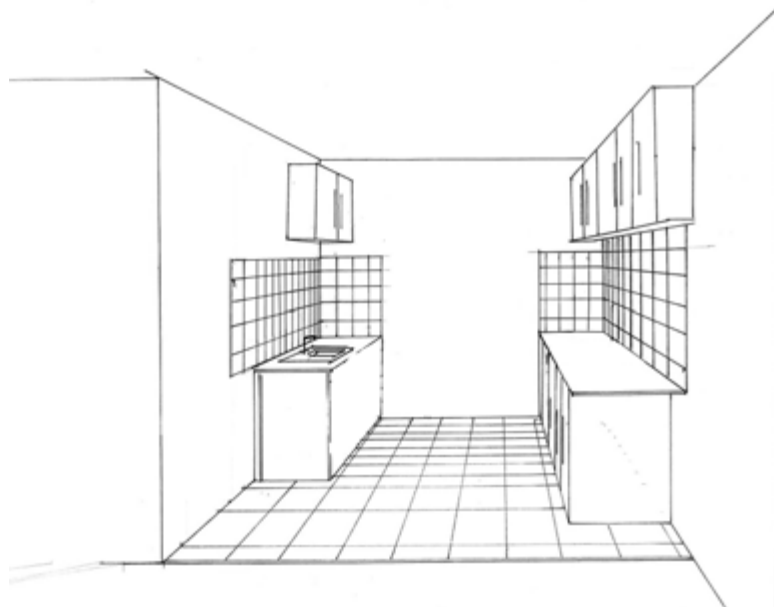

9. Complete the following list in a table format.
- Name the equipment shown below (8)
  - Draw a line diagram with arrows showing the fulcrum, effort and load (24)
  - Identify the class of lever illustrated (8)

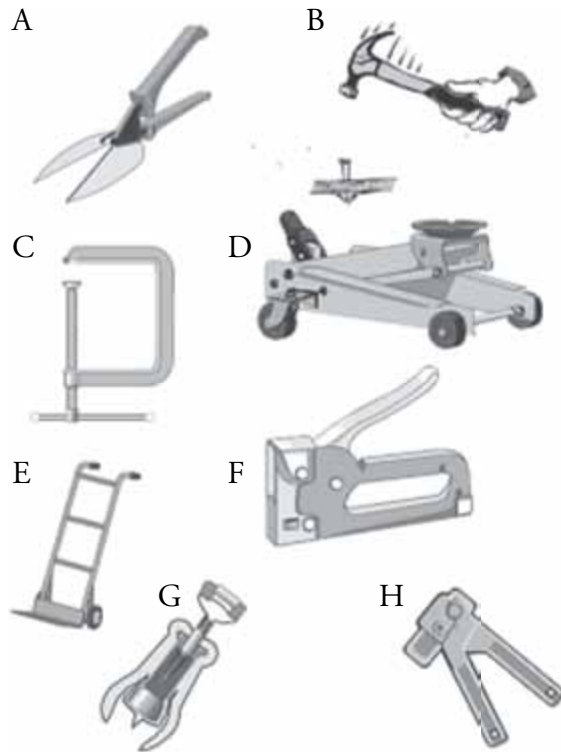

10. State the mechanical advantage of the following levers and state which class of levers it applies to. (20)

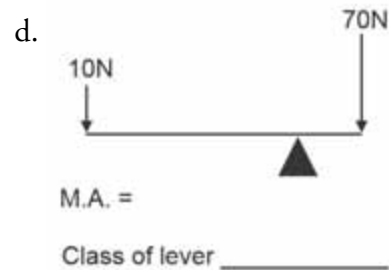
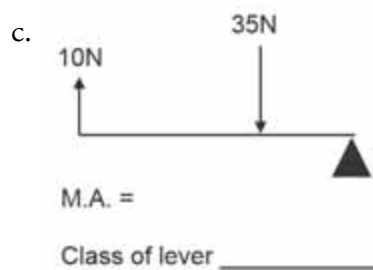
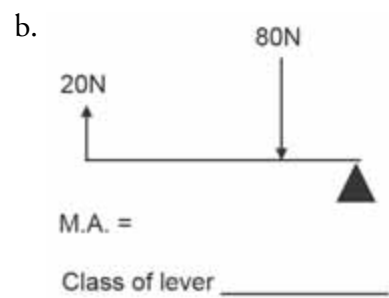
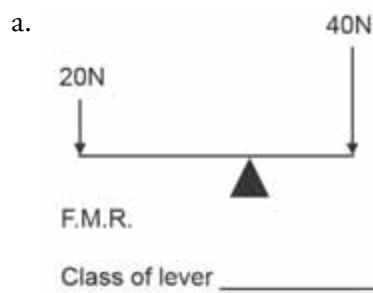

11. Explain the differences between a pneumatic and hydraulic system. (2)
12. Say which system provides a better mechanical advantage and state why. (3)
13. Draw a working drawing of the given diagram (below) in first angle orthographic projection. (30)
- Insert at least five dimensions.
  - Approximate measurements making use of your ruler.
  - Insert the first angle orthographic sign.

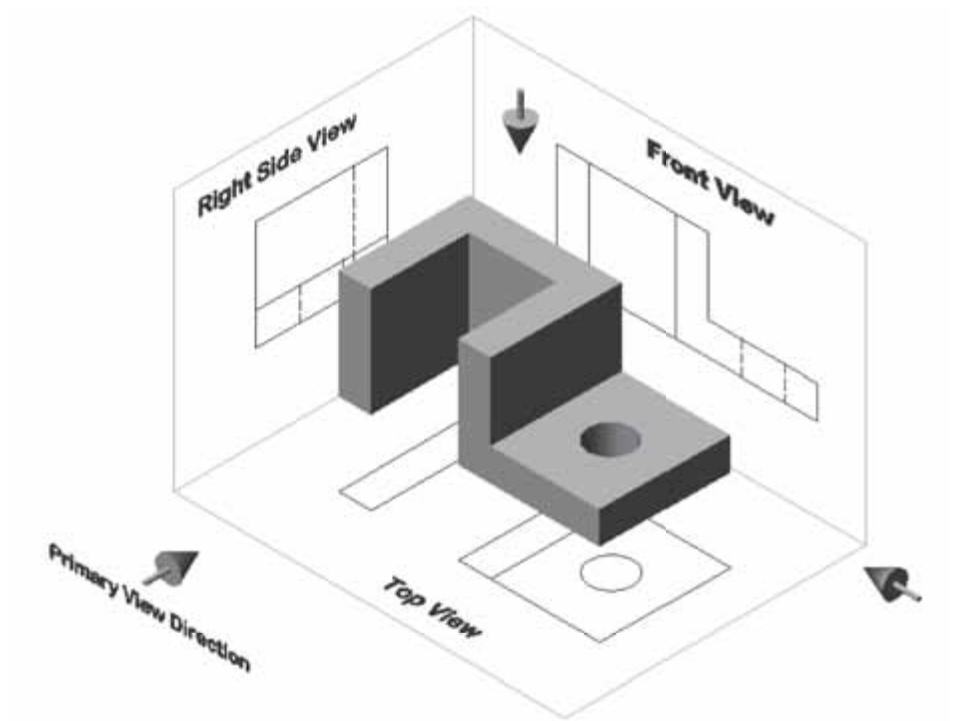

Total  $150 \div 5 = 30$

## Formal Assessment Task Memorandum

### SUMMATIVE ASSESSMENT GRADE 7

1. Briefly, explain what technology is. (3)

Technology is a body of knowledge used to create tools, develop skills, and extract or collect materials. It is also the application of science (the combination of the scientific method and material) to meet an objective or solve a problem

2. Draw a cyclic representation to explain the design process and briefly explain each step. (10)

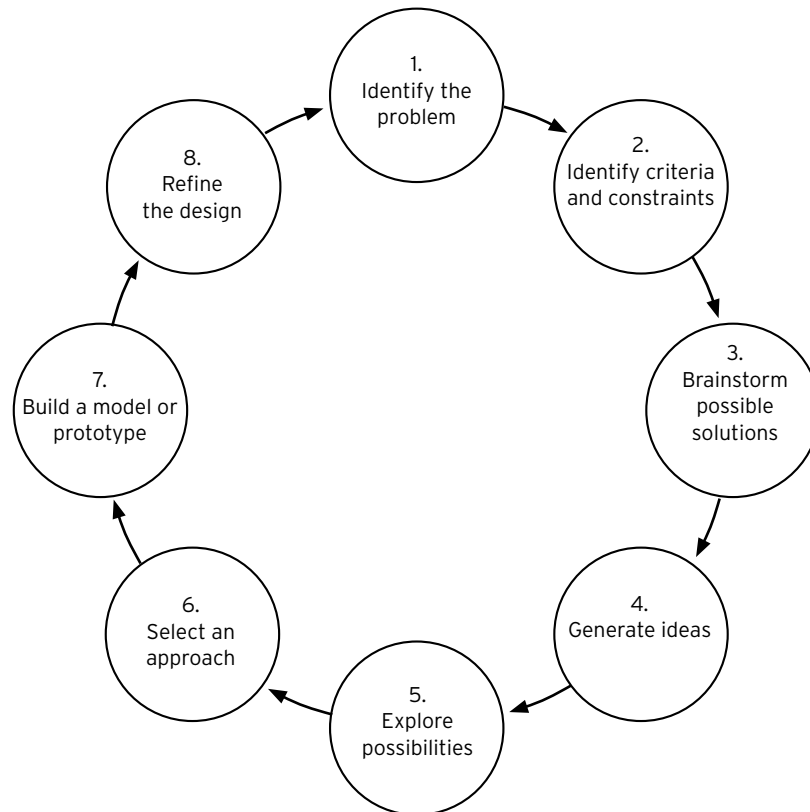

3. What do you understand by the terms:
- ergonomics: The study of people and how we live in our environment. It looks at how we use and design our environment to enhance productivity and comfort in a workplace.
  - aesthetics: This relates to how pleasing or beautiful something is, as opposed to it being only useful, practical or fit for its purpose. (2)

4. Using only a pencil and eraser, copy the following picture freehand onto the grid provided. Insert at least three important dimensions. (6)

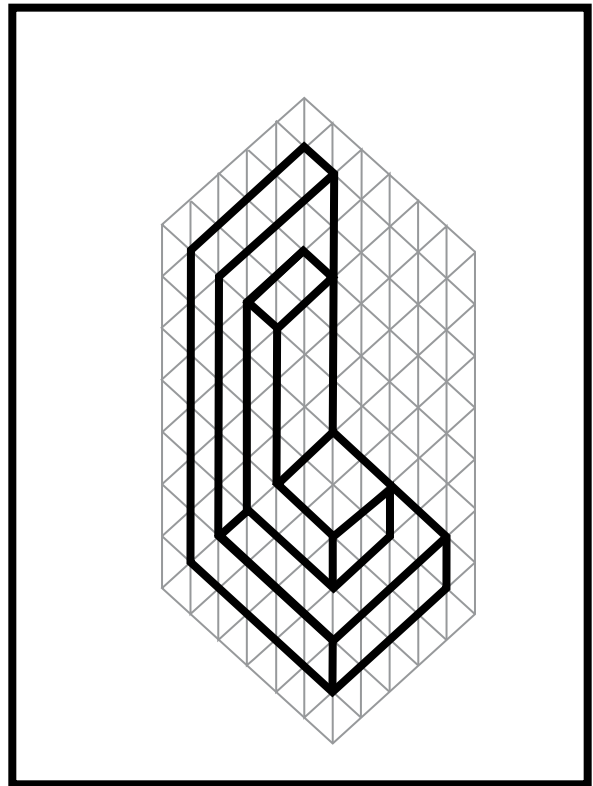
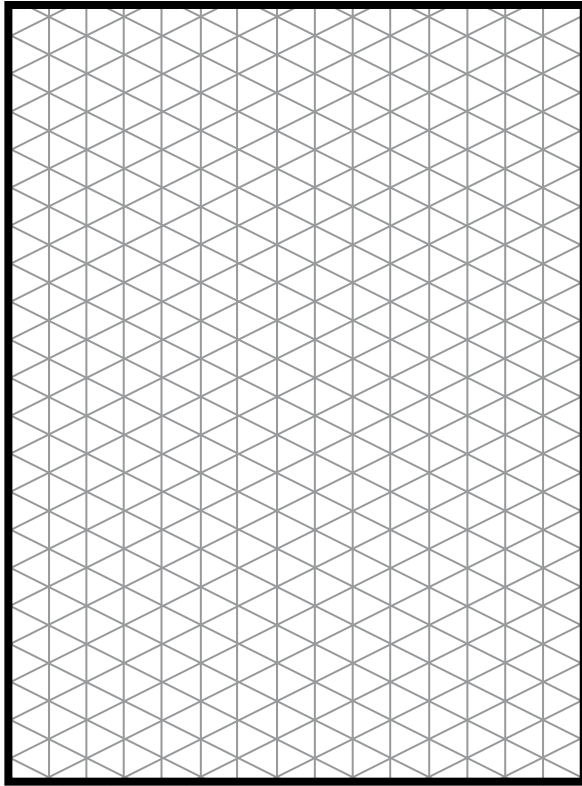

THE DIAGRAM WILL BE THE SAME AS THIS IS ONLY DONE IN PENCIL

5. Redraw the following diagram as accurately as possible. Use measurements given in millimetres. (8)

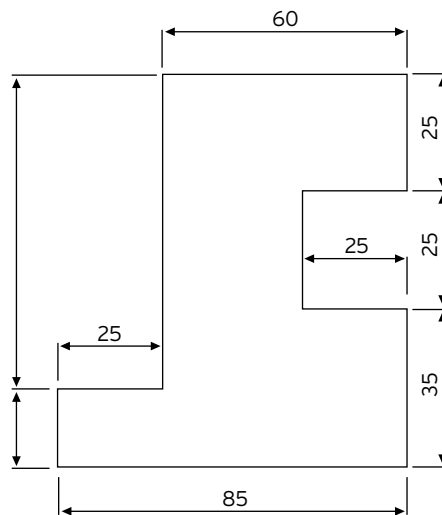

THE DIAGRAM WILL BE THE SAME AS THIS IS ONLY DONE IN PENCIL



6. Identify the six types of lines shown in the illustration below. (6)

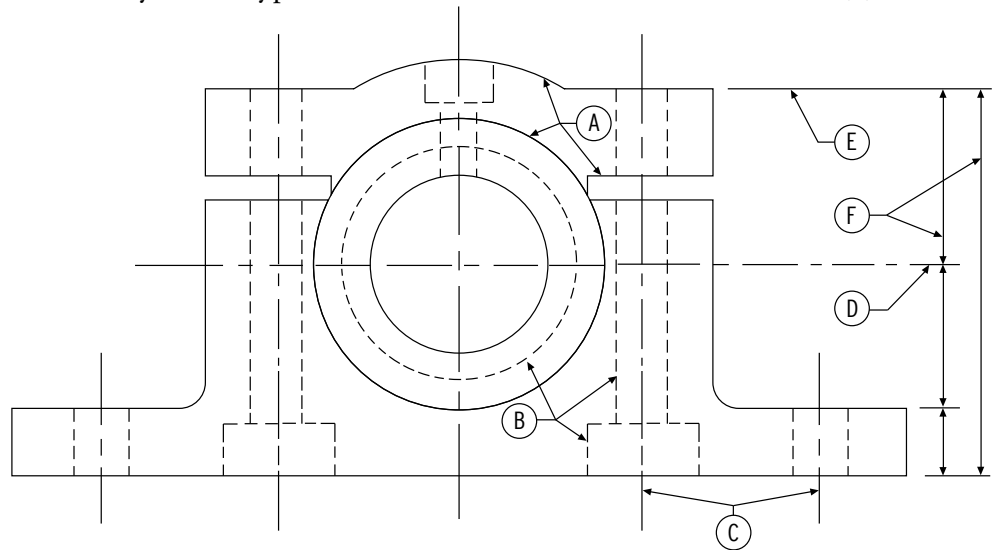

- A. Visible outline
- B. Hidden detail line
- C. Centre lines
- D. Section lines
- E. Extension lines
- F. Dimension lines

7. Draw the following drawing in oblique drawing, making use of the following measurements. Make use of approximate dimensions, for example: A=65mm, B =40mm, C=20mm, D=25mm. (10)

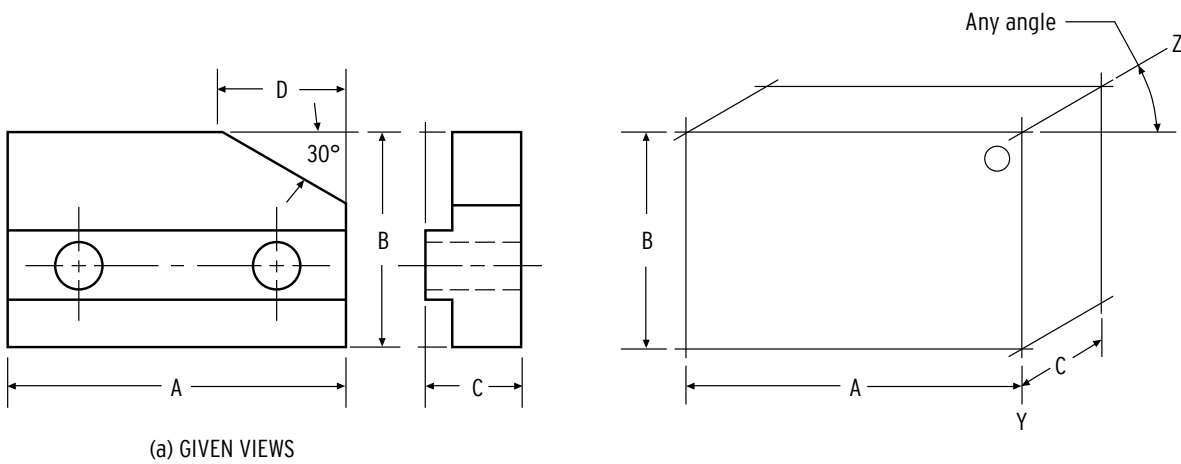

(a) GIVEN VIEWS

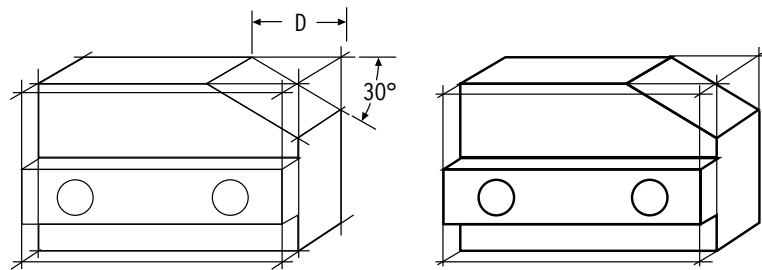

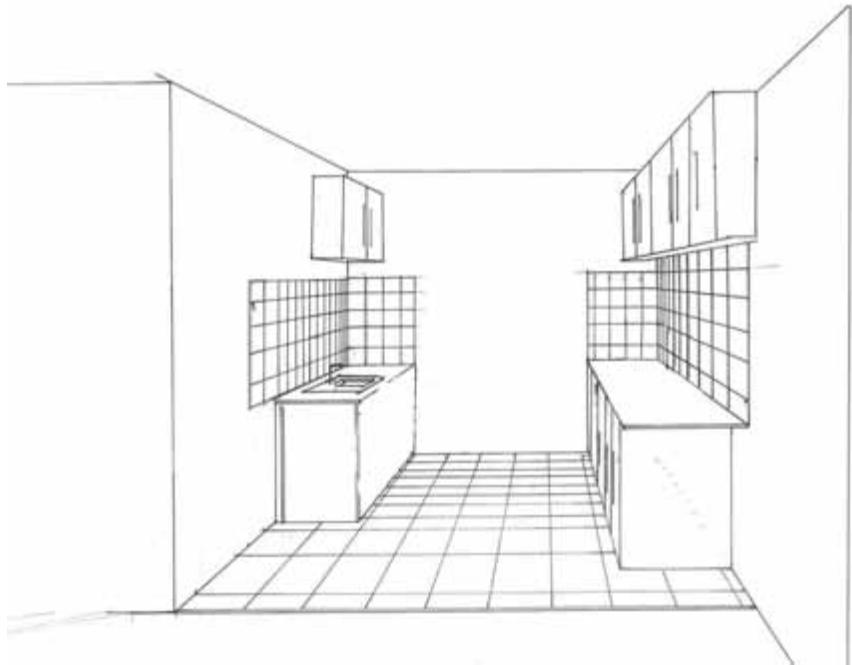

8. Redraw the following illustration of a room using single point perspective techniques. (10)

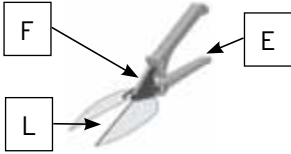
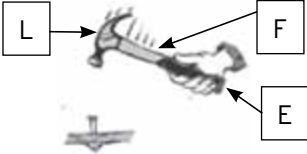
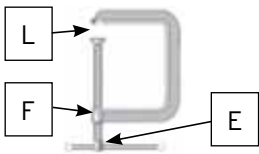

9. Complete the following list in a table format. (8)
- Name the equipment shown below (8)
  - Draw a line diagram with arrows showing the fulcrum, effort and load (24)
  - Identify the class of lever illustrated (8)

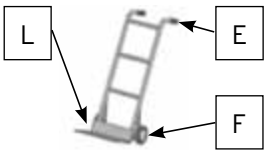
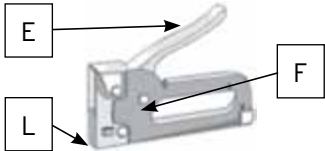
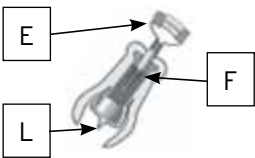
a. NAME OF EQUIPMENT	b. LOAD; EFFORT; FULCRUM	c. CLASS OF LEVER
A. shears		First-class lever
B. hammer		Third-class lever
C. G-clamp		First-class lever

D. hydraulic jack		First-class lever
E. trolley		Second-class lever
F. heavy-duty stapler		Third-class lever
G. wing corkscrew		Second-class lever
H. rivet gun		First-class lever

10. State the mechanical advantage of the following levers and state which class of levers it applies to. (20)

- $MA = 2$  : first class
- $MA = 4$  : Second class
- $MA = 3.5$  : second class
- $MA = 7$  : First class

11. Explain the differences between a pneumatic and hydraulic system. (2)

- A hydraulic system works with pressure created by fluids, such as brake fluid or hydraulic oil. This is pressure created by fluid (liquids). Oil is incompressible.
- A pneumatic system works about the same, however the pressure is created by compressed air. Air can be compressed.

12. Say which system provides a better mechanical advantage and state why. (3)

Hydraulic – because the oil that is used as a fluid cannot be compressed and forms an even distribution through the cylinders.

13. Draw a working drawing of the given diagram (below) in first angle orthographic projection. (30)

- Insert at least five dimensions.
- Approximate measurements making use of your ruler.
- Insert the first angle orthographic sign.

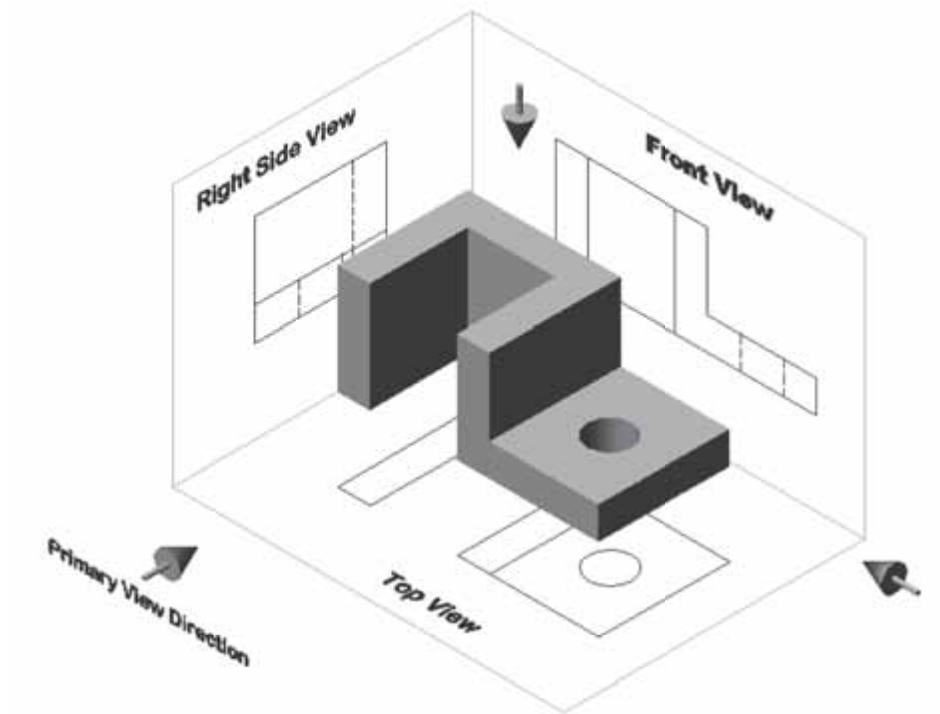

Total 150 ÷ 5 = 30

**Informal assessment task**

In the course of the term the learners will learn about graphic communication. This will enable them to use first angle orthographic projection, draw three different views and use scale, dimensions and line types. The five forces, static and dynamic forces, and their action on structures will be discussed. The effect of even and uneven loads will be examined as will the properties of various construction materials. They will then solve a particular problem facing a community living on the far side of a river from a city. As teams they will be required to compete for the contract to solve the problem.

For the informal assessment task the learners will come up with designs for a new cell phone tower in the area close to the school. The existing reception in the area is very bad, there are very few landlines in the area and most people rely on their cell phones as a way of communication. However, the community is very concerned about the impact which this tower could have on the environment. It wants the tower to blend in as far as possible with the environment. The learners will be divided into teams for the informal assessment task and each member will be assessed on the part he or she played in the investigation, designing and making process.

Here is an analytical rubric to assess design capability in the informal assessment task at the end of this module:

<b>The learner is able to:</b>					
<b>LEVELS OF COMPETENCE</b>					
	<b>Exemplary</b>	<b>Competent</b>	<b>Developing, but not yet mastered</b>	<b>Progressing</b>	<b>Progressing</b>
	<b>5</b>	<b>4</b>	<b>3</b>	<b>2</b>	<b>1</b>
<b>Generate and develop design ideas</b>	Using drawings reflectively to generate new ideas	Progression of ideas across or within drawing	Design ideas are generated but not developed	Simple sketch showing object to be made	Drawing a picture not designing a product
<b>Explore the possibilities of the problem/the need</b>	Combining novel solutions to produce innovative design	Using drawings to develop novel design solution/s	Recording possible creative solution/s to the task	Stereotypical response, showing little creative thought	Design possibilities are not addressed in the drawing
<b>Address the constraints of the problem/need</b>	Task constraints treated as part of iterative process	Task constraints considered as the design proceeds	Records way to address task and/or client needs and wants	Drawing shows some understanding of task constraints	Minimal understanding of task/user needs
<b>Plan the look of the product</b>	Ideas about finishing are developed within overall designing	Ideas about finishing are added to design while drawing	Overall decoration scheme considered	Little consideration of final appearance of product	Appearance of the product is not considered
<b>Communicate design ideas</b>	Clear enough for somebody else to make the product	Conveys sense of the object to be made e.g. Working drawing	Conveys some sense of the object to be made e.g. indicates the materials	Simple unlabelled sketch(es); relying on shared meanings	Use of narrative or other drawing genre
<b>Plan construction</b>	Constructional issues considered on route to final design	Drawing demonstrates consideration of construction	Drawing indicates some consideration of construction	Minimal consideration of construction while drawing	Yet to define the design task
<b>Evaluate while drawing</b>	Changes made as a result of considering design drawings	Decisions made about product while drawing	Considered and rejected a range of designs	Minimal evaluation at drawing phase	Yet to define the design task
<b>Provide a basis for making</b>	Using drawings as a resource during making	Clear development path through drawing into making	Object is one of the ideas drawn	Product relates to ideas recorded in the drawing	Making an object seen as separate new activity

Comments to improve the learners' performance in design capability:

## Unit 4.1 Introduction to structures

### Week 1

#### Lesson 1

The learners will look at the definition and purpose of structures to contain, protect, support and span. They will also look at the classification of structures, namely natural and man-made. Read through the introduction with the class as this will familiarise them with the area to be covered and will remind them of the previous term's work. The following resources will be required during the course of the term:

- Ice-cream sticks
- String
- Matches
- Stiff cardboard (10 large sheets)
- Punch
- 30 paper fasteners
- Newspapers (large pile)
- Sticky tape
- 10 tiles
- Straws
- Sosate sticks
- Dowel sticks
- Wooden sticks used for stirring tea/coffee
- Elephant grass
- Thin strips of thick cardboard
- Wire
- Cardboard

#### What is a structure?

Discuss the various structures which can be seen in your classroom, the school buildings and the buildings around your school. Before opening the Learner's Book ask the learners why we build structures of different kinds. Look at the differences between natural and man-made structures by comparing a tree with a house. Discuss the different purposes of a structure, such as to support, span and protect. In the class discussion answer the questions about structures in the Learners' Book.

## **ACTIVITY 1** The purpose of structures LB p. 59

Pairs

1. Hold, span
2. Enclose, contain
3. Protect, enclose
4. Span, support
5. Protect, hold
6. Support
7. Span, hold
8. Contain
9. Span, support

Discuss with the class the difference between natural and man-made structures giving and asking for responses and examples from the environment. Discuss the human skeleton and how it supports the body, and a bee hive and the function it serves for bees. Also discuss how the structures of a ladder and a car function.

## **Week 1**

### **Lesson 2**

## **ACTIVITY 2** The classification of structures: man-made and natural LB p. 60

Pairs

1. Natural
2. Man-made
3. Natural
4. Natural
5. Man-made
6. Natural

Look at the examples of the different types of structures and discuss how they differ. Refer back continuously to the basic purposes of a structure covered in Activity 1.

The learners will look at types of structures, such as shell, frame and solid structures.

### **Types of structures**

Remind the class that different structures have different purposes. Revise briefly the various functions of structures. Now, as a class, read and discuss the definitions of frame, solid and shell structures. The learners will complete the Self-assessment Worksheet on page 64 of the Learner's Book individually. Remember to help those learners who struggle to write down their answers by asking another learner to act as a writer for them. You may also get the learner to tape his/her answers on a computer or tape recorder.



For the following week you must make sure that the following resources are available so that the learners can conduct their action research in Lesson 4:

- Ice-cream sticks
- Piece of string
- Matches
- Stiff cardboard (10 large sheets)
- Punch
- 30 paper fasteners
- Newspapers (large pile)
- Sticky tape
- 10 tiles

### Self-assessment worksheet

Structure	Frame	Shell	Natural	Manufactured	Function
Balloon		X		X	Entertainment
Skeleton	X		X		Support the body
Eiffel Tower	X			X	Tourism
Egg		X	X		Protection
Igloo	X			X	Shelter
Tent	X			X	Protection
Cultivation tunnel	X			X	Protection

## Unit 4.2 Frame structures

### Week 2

#### Lesson 3

The learners will investigate a cell phone tower as a frame structure. As a Case Study existing towers will be examined and how they are strengthened by triangulation. They will do an evaluation worksheet on the advantages and disadvantages of landline as opposed to a cell phone.

#### **ACTIVITY 3** Investigate: Cell phone tower: Case Study LB p. 63

This lesson will guide the learners towards a deeper understanding of frame structures. It will also enable them to discover how the structure has been reinforced by using triangulation. The learners will examine the various pictures provided and discuss these questions in groups.

1. The base of the structure is usually larger or broader than the top.
2. This makes the structure more stable.
3. They are made of steel or a steel alloy, sometimes in the old days, wood was used to make these structures.

4. The materials need to be very strong, rust proof and weather resistant.
5. Triangulation and cross bracing has been used.
6. The structure has been reinforced with a framework.
7. It is light and strong.
8. Yes: because cell phone coverage will be available. No: because it looks ugly and it might cause radiation,
9. Accept answers that show a knowledge of what has been covered, or that demonstrate thought.

### **ACTIVITY 4** Evaluation LB p. 64

Group

Here the learners will investigate the advantages and disadvantages of a cell phone and a landline phone. They must divide into groups of three to four and discuss the advantages and disadvantages of both types of phone. A learner should be appointed in the group to write down key ideas. You must organise and write the ideas on the board.

<b>LANDLINE ADVANTAGES</b>	<b>MOBILE ADVANTAGES</b>
Cheap	Many applications
Difficult to break	Mobile
Available all the time	Easy to transport
Difficult to steal	Available all the time
	Useful in an emergency anywhere
<b>LANDLINE DISADVANTAGES</b>	<b>MOBILE DISADVANTAGES</b>
Not mobile	Easy to steal
Few applications	Can be expensive to run
No screen	Signal not always available
No SMS facility	Danger from radiation
No Internet	Disrupt face-to-face communications

## **Week 2**

### **Lesson 4**

This lesson involves action research in which there are three practical activities to stiffen a structural material by 1: tubing, 2: folding, and 3: triangulation.

You must explain the idea behind action research carefully to the class. It involves research in the form of experiments from which the learners will be able to work out information about the section of work they are studying. It is essential that the learners understand that they must conduct the experiments accurately and record their results.

You must emphasise that the results of the experiments will enable the learners to carry out a successful informal assessment task. This is

because these experiments provide them with the skills they will need for the informal assessment task. To complete these experiments, divide the learners into groups of four and each group will conduct one experiment. They will then report back to the class on their findings.

Discuss the various roles in a group:

- The group should choose a leader who is in charge of all the members and who should make sure that everybody works well together.
- The time keeper will make sure that the work is completed in time.
- The recorder will make sure that the results are written accurately.
- The doer/s will make sure that the experiment is carried out properly.
- The group must be prepared to explain how it carried out its experiments to the rest of the class and what its findings were.
- The group must also be prepared to answer any questions asked by other groups.

The activities are Activity 5, 6, 7 and 8.

You must make sure that all of the resources needed for the experiments are available. Learners must then report back to the class about exactly what they did and the results of the experiment.

### **ACTIVITY 5**   **Triangulation LB p. 65**

Group

In this activity the learners will carry out an experiment to show that triangulation is an effective way of strengthening a structure. They will also conduct an experiment to test the rigidity of different shapes. This will influence how they make their cell phone towers for the informal assessment task. From this they will be able to see the connection between the number of sides and the number of strips required to reinforce the triangular shape. Next they will need to explain the idea of a truss to the class. Then they will make an example of a gusset plate and explain how it works and why it is necessary.

### **ACTIVITY 6**   **Towers of strength LB p. 67**

Group

This activity can be carried out by a minimum of two groups or more. It can be in the form of a competition, where the learners are required to build a tower of newspapers which is able to carry a load of tiles (the more, the better) on a platform, as far off the ground as possible. This will enable the groups to discover the uses of triangulation and strengthening techniques.

### **ACTIVITY 7**   **Tubing and folding LB p. 67**

Group

This experiment can be done by two or more groups depending on the size of the class. They will discover that hollow tubes are less

expensive than solid tubes and can resist bending as much as solid tubes. Also, they will discover that several sheets of card are stronger than one, as lamination and folding add strength. Folding also adds strength, and triangular and cylindrical tubes are very strong.

### **ACTIVITY 8** Experiment to test the strength of different shapes LB p. 69

Group

This activity will reinforce the learner's knowledge about the different shapes and how strong they are compared to each other.

#### **Self assessment worksheet**

You need to explain the value of self assessment, as it is very important that the learners take responsibility for their own learning. This worksheet will give them an idea of where their strengths and weaknesses lie at this point in the learning process. Once this self assessment has been completed they may ask you for help or reinforcement about the areas covered.

1. Laminate, corrugate and use of certain shapes in the structure.
2. To laminate something you glue several layers of material together to strengthen it. To corrugate a material you fold and insert it between two layers to strengthen the layers.
3. Hollow tubes are less expensive and lighter than other materials.
4. It was built using indigenous trees and rope. The trees were cut down and then a framework of the larger trunks was built with upright stakes dug into the ground. Smaller and thinner branches and trunks were stripped of their leaves and placed close together. They were then tied into position using rope which was braided from the vegetation. Larger trunks were then lashed to the framework horizontally to make the fence stronger.
  - No. Thicker ones are used for greater strength.
  - It is reinforced using the rope and the horizontal trunks.
5. Laminate layers together, and then varnish them.
6. A square needs a diagonal member A to C added, a six-sided figure needs three members, AC, FD, FC; a five-sided figure needs only one strut; and a triangle needs nothing as it is a strong shape and does not distort.
7. Beam A in Figure 4.26 is good as the centre is reinforced and the load is spread by the upright section of the 'T' shape, and also is reinforced by the horizontal bars of the 'T' shape to distribute the load.
8. DB and AF
9. A cell phone is useful if your car breaks down on a freeway far away from towns or houses. It is also useful when there is an emergency and you need to contact someone urgently. It means help is close at hand wherever you are.
10. The concrete beam is acting as a lintel, spreading the load of the bricks in the wall above the doors to prevent it from collapsing. The wall is being held upright by the buttresses which prevent the

wall from falling over, if force is exerted against it. The buttresses are pushing against the wall, preventing the force of any material on the other side of the wall from pushing it over.

11. The centre of gravity is lower in the second shape making it more stable. The base is also much larger than the top, which increases the stability of the structure.
12. One strut; one diagonal strut is needed in each square.
13. A is the most stable, C is the least stable.

## Unit 4.3 Investigate structures

### Week 3

### Lesson 5

#### Investigating design issues

In this week the learners will learn the different names given to various parts of a structure.

It may be necessary to include in the discussion the five different forces at work in structures. You should remind the learners that these forces need to be taken into account when designing and building a structure. Below is information on the five forces to revise briefly with the class.

#### Forces

There are five main forces that act on structures:

1. Compression

This force pushes the members of a structure together or towards each other. Struts usually use compression to keep a structure in position.

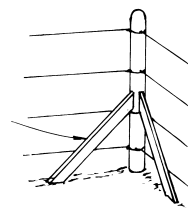

2. Tension

This force tries to pull members apart. For example when someone jumps on a trampoline, the material stretches and pulls on the springs.

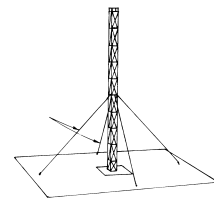

3. Torsion

Torsion is a force that causes twisting and can make the members of a structure spin or distort. You use torsional force to close a tap.



4. Bending  
A bending force causes a structure to bend.  
A beam is a part of a structure which resists bending.



5. Shearing (or tearing)  
A shearing force pushes at right angles to the structure and causes it to break or split. A pair of scissors uses shearing force to cut paper.



### **CASE STUDY 1: Cell phone towers**

During this week the learners will conduct three case studies. The first will look at the structural elements of cell phone towers and discuss the design issues such as visual pollution, stability, base size and centre of gravity.

While the learners look closely at the cell phone towers, discuss the following with them: The broader the base is the better the tower supports its height. Also discuss how the structures reinforced with guys, concrete, steel triangulation and cross-bracing are strengthened.

#### **ACTIVITY 9** Cell phone towers: Structural elements LB p. 75

Group

The groups must appoint a learner to write down their ideas and then be prepared to report back to the class. You must discuss and write the findings on the board.

In this activity the learners must look at the cell phone towers.

1. The learners should identify the parts of the structure such as beams, struts, ties, stays, guys, triangulation and buttresses.
2. They should understand how the parts of the structure stabilise it and add to its stability.
3. The learners should identify which features one should use as reinforcement techniques in the structures, such as guys, stays and struts.
4. They should identify the centre of gravity in the structure, which is where its main weight is centred.
5. Discuss these characteristics with the class.
6. Establish that the learners need to know these things for their assignment.
7. Discuss with the learners which design they like the most.
8. Discuss with them which design they think is the best for the environment.

## Unit 4.4 The impact of technology

### Week 3

#### Lesson 6

In this week the learner will look at how visual 'pollution' can be a design issue.

Discuss with the class their understanding of the word 'pollution' and then what the word 'visual' means. From their answers ask them to put the two words together and come up with a definition of the idea of visual pollution.

Pollution means littering the environment with waste products. Visual pollution is pollution which is unnecessary and pollutes the visible town or landscape, such as advertisements and buildings which spoil the skyline or block the view. They are intrusive and detract from the architecture. They are too busy visually. We can avoid this by passing municipal by-laws to control the building of large structures. They need to blend in so that the whole landscape looks more pleasing. Factors to be considered for buildings are: height, width, colour, subject material, composition of structures and their effect on the environment.

All of the above examples are reflected in the following pictures, and a discussion will involve advertising and the role of advertisements in our society and environment. This will include the questions: where and when should advertisers be allowed to advertise and who should make these decisions?

#### **ACTIVITY 10a** Investigate visual pollution LB p. 76

Individual

1. It is the visual littering of the environment with visuals such as advertisements, signs and buildings which spoil the skyline and block the view. They are intrusive and detract from the view.
2. Too many advertisements on a building, a cell phone tower obstructing the view.
3. Yes, because they are cluttered with advertisements that destroy the environment and the smog obstructs the view.
4. We can pass laws to control what is put up on buildings to ensure that new buildings fit into the landscape and we can prevent smog from factory chimneys.
5. So that they please the eye.
6. The size, shape and form of the adverts or buildings and how they will impact on their environment.
7. Adverts, signs, smog, electric power lines.

#### **ACTIVITY 10b** Investigate visual pollution (continued) LB p. 77

Individual

1. Advertisements

2. To advertise business products
3. Businesses who sell these products
4. The municipal signage section which falls under the city planning department.
5. We need to make sure that the signage does not overrun the area and that fits in with the architecture and the area.
6. No, the last picture features smog or air pollution.
7. It can be avoided by controlling the emissions from factories and industries.

## Week 3

### Lesson 6

The learners will do Case Study 2 involving the features of a school desk. This will include writing a design brief with specifications for a school desk. They will also do Case Study 3 in which they examine an existing product, namely a radio or cell phone. They will list the features and write a design brief for the product.

#### **ACTIVITY 11** CASE STUDY 1: The advantages and disadvantages of desks LB p. 78

Individual

**Now let the learners look at the pictures of the desks and answer the questions.**

- One desk is almost flat, the other is slanted.
- It depends on the age of the person who will use the desk.
- Once again it depends on the user.
- Each desk must be wide enough for the user to be seated comfortably.
- There is no strain and the user should not accomplish less work than he/she would with a more comfortable desk.
- Probably wood or a similar composite.
- It is not slanted, there is not enough packing space, tables can be pushed together. Desks tend to be heavier and take up more space.
- It is easier to store things in them, they can cause injury if the lid is dropped, and they are heavier.
- Rounded tubing is cheaper, more durable and move easily manufactured than square tubing. Because it doesn't have square edges it is less likely to cause damage to the floor or discomfort/injury to the user.

#### **ACTIVITY 12** Write a design brief LB p. 79

Pairs

In pairs the learners must identify the features of the desk:

- The surface of the desk
- The lid (if it has one)
- The legs
- The storage area
- The seating if it is attached



Explain to the learners that in order to begin building any product that solves a problem a design is needed, which requires a design brief. The design brief sketches a scenario of a real life problem which needs to be solved. The problem is outlined in detail with certain rules included. Remind the learners to ask themselves:

- What is the problem?
- Who will use the product?

**SCENARIO:**

The intake of Grade 1 learners has far exceeded the expected number, and so the Grade 7s have been asked to design and make desks which will be suitable for them to use. The desks will be used in the Grade 1 classroom.

**SPECIFICATIONS:**

- The desk must be suitable in size for a Grade 1.
- It must be sturdy and hard wearing.
- It must be water resistant.
- It must be made as inexpensively as possible without compromising the above specifications.
- It must have/not have a lid.
- It must have/not have storage space.
- It must be easy to move.
- It must be easy to place alongside other desks in a group.
- It must be easy to maintain and clean.
- It must be attractive.

Ask the learners to look at the desks at which they are seated and briefly discuss with them the advantages and disadvantages of these desks. Ask for suggestions on how the desks could be improved.

**ACTIVITY 13 CASE STUDY 2: The features of a radio or cell phone LB p. 79**

Pairs

Discuss with the class how a cell phone works. As a class discuss Alexander Bell’s phone and inspect what the first cell phone looked like and how it has changed over time. The learners will now work in pairs and list the features either of a cell phone or a radio. They must then write a design brief for that radio/cell phone. Specifications must be included. Discuss the rubric against which they will be assessed.

DESIGN BRIEF	4	3	2	1	COMMENTS
Problem is stated in simple sentences					
Solution is described simply					
The function of the product is described					

DESIGN BRIEF	4	3	2	1	COMMENTS
The user is described					
The context is described					
SPECIFICATIONS:					
Were there specifications with regard to size?					
Were there specifications with regard to features?					
Were there specifications with regard to attractiveness of the design and its use?					
Were there specifications with regard to price?					
Were there specifications with regard to the target market and durability?					

Were there specifications with regard to attractiveness of design (aesthetics) and convenience of use (ergonomics)?

### Informal assessment task

You must spend time explaining the informal assessment task to the class. First the scenario must be explained: The local community has approached you as a school to come up with designs for a new cell phone tower in the area close to the school. The existing reception in the area is very bad and there are very few landlines in the area and most people rely on their cell phones as a means of communication. However, the community is very concerned about the impact this tower could have on the environment. They want the tower to blend in as far as possible with the environment. You will be divided into teams for the informal assessment task and each member will be assessed on the part they played in the investigation, and in the designing and making process.

Each of you will be required to produce the following:

- A design brief with the specifications for the new cell phone tower.
- Two freehand sketches showing two different designs in 3D for the tower.
- One idea must use oblique projection.
- The other must use single vanishing point perspective.
- You must adapt your idea after the team has assessed it.
- You must list the resources to be used.
- You must list the tools to be used.
- You must do a working drawing for the cell phone tower showing one face in 2D.

The team:

- will choose the best idea and adapt it
- will build the model using safe working practices
- must develop a rubric to evaluate the other teams' models
- must plan a joint strategy to present the model and plans
- must present their design sketches, modifications, plans and models to the class
- each team member must explain his/her role in the work
- must draw a poster giving an artist's impression of their tower using single vanishing point perspective.

In addition:

- Each team member must keep a portfolio of their work for the informal assessment task
- The informal assessment task will account for 70% of the term mark.

During the next couple of weeks the learners will be focussing on the informal assessment task. Tell them that this is the task for which they have prepared during the previous activities. It has been designed to give the learners the opportunity to develop and demonstrate their levels of ability.

Teamwork will play an important role in the informal assessment task and that is why many of the previous activities have been structured in groups.

Divide the class into teams for the informal assessment task  
Go through the following roles of each member of the group:

- The leader will be chosen by the members of each group. He/she must be able to motivate the group and make sure that the group works together.
- The time keeper will make sure that the group keeps to the time deadlines and completes the task on time.
- Each member must take responsibility for completing their sections of the task.
- If there are disagreements the leader must attempt to iron them out. Failing that, your advice must be asked.

The following resources must be collected by you and the teams must decide which of these they will use. They may decide on other resources which they will then need to access:

- Straws
- Sostie sticks
- Dowel sticks
- Wooden sticks used for stirring tea/coffee
- Elephant grass
- Thin strips of thick cardboard
- Wire
- Cardboard

## Unit 4.5 Design skills in structures

### Week 4

#### Lesson 7

The learners need to examine the scenario of cell phone towers, which are built everywhere using materials to ensure stability, strength and rigidity (stiffness).

The individual learner needs to write the design brief with specifications for a new cell phone tower. At a minimum, the cell phone tower should consist of struts made of found materials like elephant grass or rolled paper dowels. It should show reinforcement using triangular webs, gussets and internal cross-bracing. One of the design ideas must involve disguising the tower so that it blends in with the environment, avoiding visual pollution.

In this week the learners will be writing a design brief for their own cell phone tower. They will use the drawing skills learnt in the first term to produce two freehand sketches in 3D, one using oblique and the other using a single vanishing point perspective. They will also need to take into account the element of visual pollution when designing their tower. Refer them back to the work done earlier in the term on visual pollution.

#### **ACTIVITY 14** Write a design brief for a new cell phone tower LB p. 82

Individual

Discuss the rubric for the cell phone tower in detail with the learners so that they understand very clearly what is expected of them.

### Week 4

#### Lesson 8

In this lesson the learners need to sketch their initial ideas. The individual learners will draw freehand sketches to show two different design ideas in 3D for a cell phone tower to be erected near the school. They will draw one idea using oblique projection and the other idea using single vanishing point perspective.

#### **ACTIVITY 15** Sketch the initial ideas for a new cell phone tower LB p. 83

Individual

The learners will now work on at least two freehand sketches showing different design ideas in 3D. Explain to them that they should use the drawing skills learnt in Term 1 to sketch the cell phone tower. They must also bear in mind the impact of the tower visually on the environment. Refer back to the previous work done on visual pollution earlier in the term.

You must move around the class providing assistance and suggestions where needed.

## Unit 4.6 Design ideas

### Week 5

#### Lesson 9

In this lesson the learners need to form groups to examine and discuss the various design ideas of the individuals in the group. They will evaluate the sketches of each individual to determine the advantages and disadvantages of each design. The individual learners will then adapt their own design ideas in terms of the group evaluation, making any necessary improvements. They will also produce a list of the resources and materials needed to build the tower. You must remind them about safety factors before they begin building their models.

#### **ACTIVITY 16** Discuss and evaluate your design ideas LB p. 84

Group

The learners must be divided into groups of five to discuss the design ideas of each member.

Remind them to be constructive and helpful in their evaluation.

They must list the advantages/disadvantages in the table provided. Each learner will now modify his/her drawing according to the recommendations.

### Week 5

#### Lesson 10

In this lesson the learners look at the making process, which includes working drawings, choosing materials and tools, and building the model.

Measuring and simple tool skills must be developed. The learners need to understand that safe, cooperative working is a key skill and is needed in the world of work. Each learner will list the resources to be used and draw a working drawing for the cell phone tower showing one face in 2D.

#### **ACTIVITY 17** Create working drawings for the tower LB p. 86

Individual

The learners now individually create working drawings of the tower. They must list the resources and tools needed to make the tower. It might be good for them to look at the resources available to them, and in their groups to discuss the advantages and disadvantages of four of the resources listed. Remind them that they may use other resources as well.

## Unit 4.7 Making skills

### Week 6

#### Lesson 11

During this week the learners will select the best plan or design of their team. They will develop the design they chose by consensus from the plans drawn by each group member. They will then plan a joint strategy and design a poster to show an artist's impression of the cell phone tower using a single vanishing point perspective. They will also begin building the model, bearing in mind safe working practices. The team adapts a final plan (working drawing) from these inputs and assesses them informally. This will test their making and evaluation skills.

## Unit 4.8 Evaluation skills

### ACTIVITY 18 Choosing a design LB p. 88

Group

The learners will return to their group and through discussion they will choose one of the five drawings which the team agrees will be the best to make. Discuss with the learners:

- As a team they must be able to explain why they chose that drawing in particular.
- Emphasise the length of the presentation time.
- Discuss the importance of a team strategy.
- Each learner must explain his/her role.
- A poster must be designed.
- The team must draw up its own rubric to assess the other teams' work.
- The team must plan a joint strategy to present its model and plans.

## Unit 4.9 Making skills

### Week 6

#### Lesson 12

### ACTIVITY 19 Building the model LB p. 88

Group

This is when the learners will build the model, according to the design brief, remembering to use safe working practices. Discuss the checklist with the learners so that they can monitor their progress and make

sure that they fulfil all the criteria against which they will be assessed.

Included here are some more safety tips which you may want to discuss with the class.

## **SAFETY**

### **Tools:**

- The tools should be kept sharp: unnecessary force could lead to accidents.
- Never use a file without a handle as it could cause cuts and scrapes.
- Hammer heads should be firmly wedged onto their handles.

### **Clothing:**

- Sleeves should be buttoned or rolled up out of the way.
- Ties should be tucked into shirts.
- Shoe laces should be tied.
- Long hair should be tied up.

### **Electricity:**

- Never use faulty or frayed cords, or equipment with loose connections.
- Always switch off the current when not in use.
- Never make repairs yourself, but ask an expert.

### **General:**

- Put all tools back when not in use.
- Pick up any scraps or off-cuts.
- Clean up oil or paint spills immediately.
- If accidents occur, seek first aid immediately.
- Always report all accidents, even if small.
- Wash hands thoroughly after using oil, turps, thinners and varnish.
- Enter the room sensibly.
- Do not interfere with the work of other learners.
- Always get your teacher's permission before using equipment.

## **EXTENSION ACTIVITY**

In a group of four or five, choose one of the sections on safety and give a reason for each point. Present these to the class as a poster. This can then be put up in the technology room for other learners to look at.

## **Week 7**

### **Lesson 13**

During this week the learners will continue building their models and work in their groups to develop a rubric to evaluate the other teams' models and plans. Work must continue on the poster and on the presentation for the rest of the class. It needs to be reasserted that they need to use safe working practices. They should look again at their checklist to ensure that their progress is good and that they are fulfilling all the criteria against which they will be assessed.

## **ACTIVITY 20 Building the model (continued)**

**LB p. 89**

Group

This is a continuation of the building lesson.

### **Week 7**

#### **Lesson 14**

## **ACTIVITY 21 Evaluation skills LB p. 89**

Group

The learners continue to work in their teams, and develop a rubric to evaluate the models and presentations of the other teams. They will also design their posters and prepare their presentations as a group. This will test their communication and evaluation skills.

### **Week 7**

#### **Lesson 15 and 16**

During these weeks the learners must continue to work on their poster and on their presentations.

In these lessons the learners will give their presentations of five minutes per team. They will have planned a joint strategy to present their model and plans in which they present their design sketches, modifications, plans and models to the class.

Each learner will explain the role he or she played, and share the role of spokesperson. Learners can enhance their presentation using posters that give an artist's impression of their completed cell phone tower in position near the school, which should be drawn using single VP perspective. During the team presentations, each team uses its rubric to assess presentations of at least two other teams.

## **ACTIVITY 22 Tips for your poster and presentation**

**LB p. 90**

Group

Go through the reminders about the posters and presentation. Learners must complete the rubric for the assessment of the other teams' models.

Learners must make sure they have their presentations well organised.

#### **Formal assessment task: test**

### **Week 8**

#### **Lesson 17**

In this lesson the learners will do their term test.



**Practical assessment task**

Remember at the end of this term the learners will be doing their PAT and a test. This is designed to give them the opportunity to develop and demonstrate their ability (or capability) as they progress through the task's activities. These tasks are based on the design process which is Investigate-Design-Make-Evaluate-Communicate.

It is important that the learners are told about the PAT before they start the term's work. They will be able to focus more specifically on the concepts and skills that they learn because they have this end in mind! They should also be told about the recycling project they are going to run at the school. It might even be an idea to start the recycling project in Term 2 and also set up a recycling spot where the waste is collected neatly and out of sight.

The learner must present the full design process in Term 3 of Grade 7. The resources for the PAT are the responsibility of the school so before you start this module make sure that you have all the resources you require. You must supervise the PAT as the learners cannot take this part home and complete it there. The PAT is also assessed by you.

Here is an analytical rubric to assess design capability in the PAT at the end of this module:

<b>The learner is able to:</b>					
<b>LEVELS OF COMPETENCE</b>					
	<b>Exemplary</b>	<b>Competent</b>	<b>Developing, but not yet mastered</b>	<b>Progressing</b>	<b>Progressing</b>
	<b>5</b>	<b>4</b>	<b>3</b>	<b>2</b>	<b>1</b>
<b>Generate and develop design ideas</b>	Using drawings reflectively to generate new ideas	Progression of ideas across or within drawing	Design ideas are generated but not developed	Simple sketch showing object to be made	Drawing a picture not designing a product
<b>Explore the possibilities of the problem/the need</b>	Combining novel solutions to produce innovative design	Using drawings to develop novel design solution/s	Recording possible creative solution/s to the task	Stereotypical response, showing little creative thought	Design possibilities are not addressed in the drawing
<b>Address the constraints of the problem/need</b>	Task constraints treated as part of iterative process	Task constraints considered as the design proceeds	Records way to address task and/or client needs and wants	Drawing shows some understanding of task constraints	Minimal understanding of task/user needs
<b>Plan the look of the product</b>	Ideas about finishing are developed within overall designing	Ideas about finishing are added to design while drawing	Overall decoration scheme considered	Little consideration of final appearance of product	Appearance of the product is not considered
<b>Communicate design ideas</b>	Clear enough for somebody else to make the product	Conveys sense of the object to be made e.g. working drawing	Conveys some sense of the object to be made e.g. indicates the materials	Simple unlabelled sketch(es); relying on shared meanings	Use of narrative or other drawing genre
<b>Plan construction</b>	Constructional issues considered on route to final design	Drawing demonstrates consideration of construction	Drawing indicates some consideration of construction	Minimal consideration of construction while drawing	Yet to define the design task
<b>Evaluate while drawing</b>	Changes made as a result of considering design drawings	Decisions made about product while drawing	Considered and rejected a range of designs	Minimal evaluation at drawing phase	Yet to define the design task
<b>Provide a basis for making</b>	Using drawings as a resource during making	Clear development path through drawing into making	Object is one of the ideas drawn	Product relates to ideas recorded in the drawing	Making an object seen as separate new activity

Comments to improve the learners' performance in design capability:

All of the materials and tools the learners need before you start the lesson in week 1 must be ready. Before presenting any of the lessons, as a teacher, you must make sure you have tried out the experiments of putting the circuits together yourself. You cannot expect the learners to know how to do this if you cannot carry out the exercises yourself!



### **SAFETY**

#### **TIP**

Have a jar for the iron filings – they are small and will get everywhere. Make sure that the jar is placed in a safe place. If it is a glass jar make sure it is handled with care.

Here are the materials you should have ready for Week 1:

- A variety of magnets
- Iron filings
- Plastic bags that seal for storing iron filings
- Wood, plastic, copper, nickel coins and similar objects
- Posters of different magnets and different articles or pictures of interest about magnets
- Books on magnetism

Before starting the projects you must take into account the learners who have barriers to learning. There are many different elements that can be put into the project to help these learners. Even during the practical activities some learners may need a worksheet with bigger print because they have visual barriers. Learners may need a reader to help them with the projects. Some learners may need a scribe to record their work. If the school or learners have their own laptops they should be allowed to use language programmes like 'Dragon Speak'. The learner will speak into a mike on the headset which recognises the voice of the learner and types out the information that the learner provides. All these activities are allowed in the final Grade 12 exams – this is called accommodations. Encourage those learners with barriers to be open about it and not to worry about what their peers think. Remind the learners that not all people are 'wired' the same way!

**Unit 5.1 Investigation skills****Week 1****Lesson 1**

Below is an outline of what will be covered in the first week. This will be covered in two one hour lessons. At the end of each week you will have a self assessment or peer assessment task to revise the work you have covered in the two hours. The learners need to investigate magnetism and the different types of permanent magnet, such as the bar and horseshoe magnets.

**ACTIVITY 1 Magnets LB p. 94**

Group

Collect different magnets so that the learners can play with them. The Science department should also have iron filings and magnets. Make sure, when the learners are working, that they work safely and neatly with the iron filings. Get the learners to walk around the classroom and see to which objects the magnets will stick. They may even go outside onto the playground.

It is also important to have a hand brush and pan handy just in case the learners mess with iron filings, which they can clean up straight away. (A magnet wrapped in paper will pick up iron filings easily, without fouling the magnet in iron filings.)

Discuss the '**Did you know?**' box. Remind the learners that the Earth acts like a giant magnet and that it also has a giant magnetic field. They may discuss the diagram of the Earth with the magnetic fields marked.

There are two different magnets the learners will learn about and use in this module. These are the horseshoe and the bar magnet. Their names are the result of their shapes: The one looks like a horseshoe and the other looks like a bar or piece of metal. These magnets are also easy to find and buy.

If your school has computers and the Internet, then the learners can research magnets and magnetic fields. Make sure you have posters ready about magnetic fields once the learners have finished with the experiments.

## ACTIVITY 2 Extension activity - Lots of fun!

LB p. 96

Group

The learners may go outside with the magnet on a string and dangle it. It always points toward the North and South poles. This is because it is lining up with the Earth's magnetic field, just like the iron filings will when the learners see the demonstration.

As a teacher you need to do informal assessment. Walk around while the learners are working on the different activities. Help them if they are not achieving what you have set out for them to do. Check that they are working safely with all the equipment. Remember we cannot really see the magnetic field, but we can see how it moves the iron filings around.

The learners perform Experiment 1 and go on to Activity 3 to perform Experiment 2.

## ACTIVITY 3 Extension activity (continued)

LB p. 97

Group

The learners will use the magnets to perform Experiment 2. The possible answers to both experiments are below.

- What did you observe when you sprinkled the iron filings over the paper covering the magnet? Draw what you see.
- Can you explain why the iron filings behaved that way?
- Do you see the same patterns as you did with the compass tracing?
- What do you think will happen when you use two magnets? Trace them and do the same experiment and record what happens.

Possible answers:

- The iron filings make a type of arch shape from the south pole to the north pole.

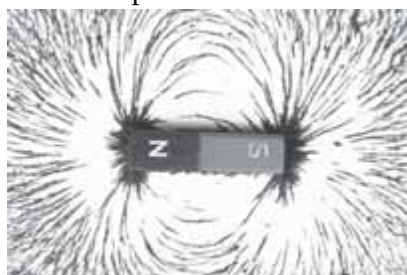

- They are forming the magnetic field. It is the field that we cannot see but it is there.
- The pattern of iron filings caused by the compass is similar to the magnet field.
- If the two magnets are put in a straight line, next to each other, they will make the same pattern as a single magnet around the individual magnet. If the magnets are placed parallel to each other



### SAFETY CONCERNS

Be sure that the learners DO NOT put iron filings in their mouths!

they make a slightly different pattern. The pattern is almost like the pattern of a single magnet.

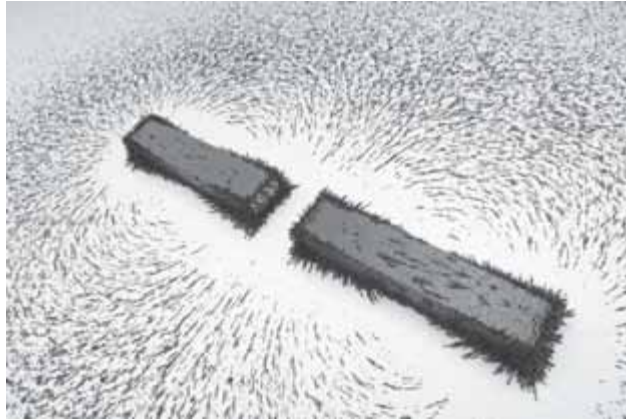

**Learners with learning barriers:** for visually-impaired learners, you should build a model of the magnetic field on paper using sprinkled sand and glue along the line of the magnetic field.

### **Extension activity with magnets**

The learners may research the magnetic field that is formed around a small magnet and compare it with the large magnetic field formed by the Earth. Discuss if you can see magnetism. How? What does it look like?

Possible answers: The Earth's magnetic field looks similar to the magnetic field of a single bar magnet. The arc of the magnet field sprays out from the north pole to the south pole.

### **Extension activity (continued): Making a rocker toy with magnets**

Learners will use two magnets to make the toy. This activity will show learners the two ends of a bar magnet. There is the north pole and the south pole. The principle of the toy is that one magnet hangs on a string and the other should be placed on the desk. The magnet on the toy is affected by it and swings in a wild, chaotic pattern.

## **Week 1**

### **Lesson 2**

As an optional extension the learners need to find the shapes of magnetic fields using iron filings. For group work they will look at substances that stick to a magnet and tabulate the results.

#### **ACTIVITY 4** What sticks to a magnet? LB p. 98

Group

The learners will experiment with different materials to see what will stick to a magnet. They will test different items around the classroom. They may also use different items from their desks or from outside the classroom. Once this is done they should copy the table into their exercise books and then record their findings.

Check that each learner records their findings with the magnetic fields. They then need to test materials to see if they are attracted to the magnets. The learners will be able to conclude that some metals do stick to a magnet and that non-metals do not. If paper clips with plastic coatings do not stick get the learners to explain why they think this is so. (The plastic coating is preventing the metal sticking to the magnet.)

### PEN AND PAPER ACTIVITY

You should print out the questions below and give them to the learners:

1. Name some materials that interact with magnets and some materials that do not interact with magnets.
2. What do all the materials that interact with magnets have in common?
3. What happens when you bring a compass near a magnet? How does it depend on where you place the compass?
4. Draw what you think the magnetic field will look like around a single bar magnet.
5. What happens when you sprinkle the iron filings over the paper covering the bar magnet? Draw it.
6. Explain why the iron filings behaved in this way.
7. Draw what you expect to see if you sprinkle iron filings over two bar magnets.

#### Possible answers:

1. Some of the materials interact with the magnets, and the magnet sticks to them. Things like a metal ruler, compass, the metal leg of the desk, pole, hinges of the door, door handle. Things that do not interact with the magnet, and that will not 'stick' to the magnet include: wooden ruler, eraser, wooden desk top, door, shelves and books.
2. The items that will stick to a magnet are made of some form of metal.
3. When you move the magnet to different positions around the needle, it follows the magnet to the different positions.
4. See first illustration below.

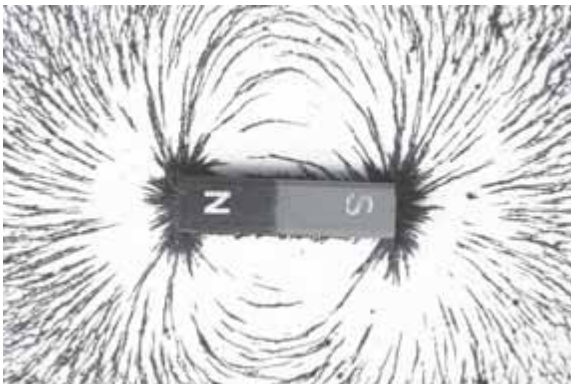

5. They spray out in an arc (See illustration above left).
6. They move into this position because this is the magnet field of the magnet.
7. See the illustration of two bar magnets and their magnetic field.

## **EXTENSION: 3-D magnetic field around a cow magnet**

You should demonstrate this. You can use simple materials.

### **What you need:**

- Clear plastic or glass bottle
  - Roll piece of plastic to fit down neck of bottle – bottom end sealed with tape
  - Cow magnet
  - Iron filings
1. Pour the iron filings into the bottle. There should be just enough to coat the bottom of the bottle to a layer of about 5mm.
  2. Insert the tube into the bottle.
  3. Tape the tube at the top of the bottle's neck to seal it.
  4. Lower the cow magnet into the bottle and see what happens.

### **Possible answers for learner's test on page 100:**

1. Magnetism is when one type of material puts a force on another material. This will either pull that material towards it or repel it.
2. The law of magnetism states that like poles repel each other and unlike poles attract each other.
3. There are three types of magnet: permanent, temporary and electromagnets.
4. Experiment 2 – They will get iron filings and a bar magnet and a piece of paper. Put the bar magnet underneath the piece of paper. Carefully sprinkle the iron filings over the paper above the position of the bar magnet. The shape of the iron filings will form the magnetic field.
5. An electromagnet is created when you wind insulated copper wire around an iron nail. The electric current flows in the wire coil (solenoid) a magnetic field is created and this is amplified by the iron core.
6. Magnetite does not lose its magnetism.

Ensure that the learners have recorded the self assessment table in their books, and discuss their responses with them.



## Unit 5.2 The impact of and bias in technology

### Week 2

#### Lesson 3

In Week 2 learners will look at magnetic metals and scrap metals that can be recycled. This will be a two hour lesson. At the end of each week the learner will have a self-assessment or peer assessment to revise the work they have covered in the two hours. The learners need to look at metals that are attracted by a magnet. They should test metal samples and complete a table of the results. This will lead on to the Case Study about recycling scrap metals.

Before starting Week 2 you should send out a letter to the parents, learners and staff at the school about collecting materials that can be recycled. The school will also generate a great number of materials that can be recycled. Below is an idea for the letter that the Grade 7 learners should send out. Each class should take them and put them in their homework diaries.

Letterhead for the school Address Date
Dear Parents
The Grade 7 learners are starting a recycling scheme at the school. They will be raising funds for the school to buy ..... (e.g. Computer).
Please collect items for them to recycle. Please rinse them before sending them.
Here are some of the materials they are collecting for recycling:
<ul style="list-style-type: none"><li>• Clear glass and coloured glass</li><li>• Newspapers and magazines</li><li>• Plastic containers</li><li>• Plastic bags</li><li>• Scraps of metal</li><li>• Wire (insulated as well)</li><li>• Off-cuts of wood</li></ul>
Yours sincerely,

## **ACTIVITY 5** What metals stick to a magnet? LB p. 99

Group

Make sure the learners draw their table in their exercise books before they start doing the experiment of testing with the magnets. Help the learners to collect different items to test with the magnet. Have a discussion about what will stick to the magnet. If it does not stick to the magnet see if they are able to work out why.

Encourage the learners to collect the different metals from home as well. You should have different examples in the classroom.

It is important to get the whole school involved in recycling. This should be carried out throughout the year and not only when the Grade 7 learners are doing their project.

### **Did you know?**

The paper clip: discuss the design with the learners. You should show them different examples of paper clips and then show some with a plastic coating and some without a coating. They should test them on the magnet. A fun exercise is for the learners to test how many paper clips their magnet can hold without them falling off. They will see if the plastic-coated paper clips are held at all.

### **These are the materials you will need for Week 2:**

- Magnets
- Samples of steel, iron, nickel, copper, lead, aluminium and brass
- Posters on recycling
- Advertisements on different firms that recycle materials
- Plastic bins or metal bins or big cardboard boxes for collecting recycled materials
- Labels for the recycling containers

Around every magnet there is an invisible magnetic field. This field is what attracts items such as paper clips and nails to the magnet. If we use iron filings, we can see the effects of this invisible field.

## **Week 2**

### **Lesson 4**

In this lesson the learners will look at the Case Study: Recycling scheme for your school. They will tabulate a record of waste produced by the school and work out a viable strategy to raise funds by recycling.

## **ACTIVITY 6** Recycling LB p. 100

Group

### **Case Study**

A visit to the local 'dump' could be very interesting for the learners. People throw away things without thinking about what it is doing to

our environment. Encourage learners to sort out their trash. Lots of the materials can be used to make compost – you may want to start an organic vegetable garden at school.

This lesson will cover recycling at the school.

You should set an example by bringing materials from home that can be recycled. Explain to the learners what happens to the materials and what products they are recycled into. They should also discuss how they can make money for the school. It might be an idea to set goals on what they would need for the classroom if they make 'x' amount of money. They should first set small goals and then bigger goals, such as a computer for the classroom.

At the beginning of this module you should have set up a 'drop off' point for the recycling materials. It is important to keep this area tidy. You do not want rats or disease around the area!



#### **SAFETY TIP**

Always wear gloves when handling recycled materials. Buy some gloves from the local supermarket, such as the ones used for washing dishes. The learners do not have to use industrial or heavy-duty gloves as long as they keep their hands clean. Remember to ensure that the learners wash their hands after sorting the materials.

There will also be some objects with sharp edges on recycled materials. Thick gloves will protect the learners' hands to a certain extent but always have plaster and disinfectant in the classroom to clean up any scrapes or cuts. Remember that the learners should do this themselves. If they are unable to do it, make sure that the person giving the 'first aid' is wearing protective gloves.

Have a discussion about the gleaners in the big cities that are doing a lot of good. Explain how this is an honest living for them. Compare this with other people who steal cables. It is costing the government a great deal of money and in the long run the citizens end up paying for it!

#### **ACTIVITY 7 Recycling (continued) LB p. 102**

Group

The learners should be divided into groups. They should be given a different recycled material to collect and tabulate. Then they should decide which materials are the easiest to collect and also how much money can be made from them. It is important to note that each school will be different. There are not always places in the towns or cities where you can sell the waste materials. Make sure you research your area and whether it is cost effective or not, and explain how the waste materials will be transported to the collection point or factory.

The learners must record this in their exercise books. If they work hard at the recycling project, reward them with, for example, a day at the movies.

## Unit 5.3 Electrical systems and control

### Week 3

#### Lesson 5

The learners will look at simple electric circuits and following this they will demonstrate a simple electric circuit and a sketch showing component symbols. Below is a breakdown covering the third week. This will be a two hour lesson. At the end of each week you will have a self-assessment or peer assessment to revise the work you have covered in the two hours.

It is important to have the different components to show the learners. You will give a demonstration on how to make a simple circuit. Start the circuit by attaching the one wire to the cell. Use vinyl tape (electrical tape) to attach the insulated wire to the positive end of the cell. Attach another length of wire to the negative end of the cell. If the learners are not familiar with the positive and negative sides of a cell show them the markings on the cell. One end has a plus sign and the other end has a minus sign.

Once the two strips of insulated wire are attached to the different ends of the cell, attach the other end to the base of the bulb using vinyl tape. The other strip of insulated wire will be attached to the side of the lamp (the metal part).

#### Hint:

The insulated wire must be stripped at both ends. If you do not have a proper wire stripper then a pair of scissors may be used. Scrape the plastic part of the insulated wire with the sharp edge of the scissors making sure only the plastic is cut. Pull off this part to expose the wire.



Scissors gently scraping the plastic off insulated wire

This should be long enough to make contact with the bulb when the vinyl tape connects the wire to the bulb. It has to be metal on metal to allow the current to flow.

## **ACTIVITY 8** Introducing electricity LB p. 103

Group

### **THE ROLE OF THE TEACHER:**

- Provide the electronic equipment.
- Provide opportunities for developing knowledge and skills when working with electricity.
- Demonstrate how to make a simple circuit

This exercise will help learners make the correct circuit with a switch and electromagnet to use on their model crane.

### **Materials you will need for Week 3:**

- Cells, buzzers, light bulbs, insulated wire (enough for all the groups)
- Posters of circuits for the classroom
- Copper wire
- Iron nails

Remember as a teacher it is important that you can build the circuit yourself. Before you expect the learners to make the circuit, try it out yourself. Then demonstrate the making of a simple circuit in front of the class. Once it is made, draw the different components on the chalkboard. Show the learners how to draw the simple circuit as a circuit diagram using symbols (as shown on page D99 of this Teacher's Guide).

The learners must learn about the different circuits. If there is not an electronic shop close by the learners will have to build their own bulb holders, switches and cell holders. Have examples of these and pictures for the learners to study.

Explain to the learners that an electric circuit is a complete electrical path that will make it possible for an electric current (Amperes – denoted with the letter “I”) to flow from the positive terminal of a battery, through the conductors and components to the negative terminal. The battery supplies the force (electrical VOLTAGE) and is denoted with the letter “V”.

A basic electric circuit consists of the following:

- A power supply which is a cell or battery (energy source)
- Conductors which are usually insulated
- A switch. When the switch is closed we have a completed circuit.

A load, such as a lamp, resistor or electric motor.

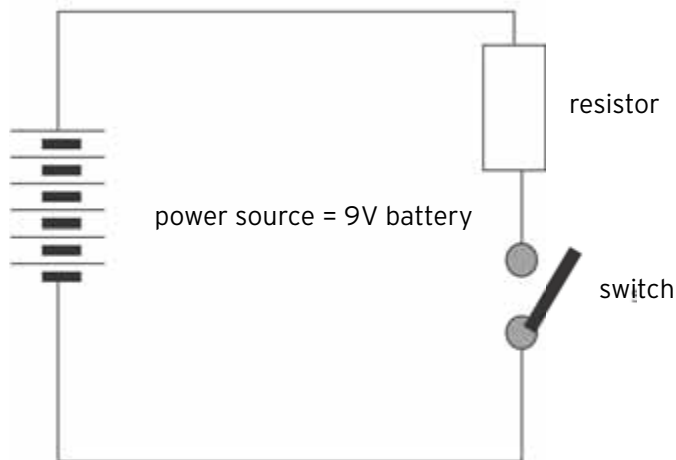

The simple circuit drawn as a circuit diagram with symbols of the components

### Did you know?





It is important to use the correct voltage. The learners must learn to check on the cells or bulbs to see whether they are the correct voltage. It is normally printed on them.

## ACTIVITY 9 Electric symbols LB p. 104

Individual

Photocopy this test to give to the learners. This will be for continuous assessment:

Fill in the symbols below:

Name	Picture	Symbol	Use
Bell			Output device: gives off sound when a current passes through it
Electrochemical cell			Input device: source of energy
Series battery			
Light bulb			Output device: lights up when a current heats it
LED - light emitting diode			Control device: allows current to flow in one direction only, and emits light

**Possible answers:** For this exercise the learners should mark their own work which they have done in their exercise books.

Pair

Once the learners have made a few circuits they will draw the circuit diagram. Make sure they have their rulers and pencil and draw neatly.



### **SAFETY**

#### **TIP**

The learners must never connect their circuits to the mains. The mains give off 240 volts, this is enough to shock and kill a person!

### **Hint**

Remind the learners about drawing their circuit diagrams. Make a small poster with the following tips:

Here are some tips for later when you draw your circuit diagrams:

- Make sure you use the correct symbol for each component
- Draw connecting wires as a straight line (use a ruler)
- Put a 'blob' (.) or a solid dot at each junction between the wires

Here is a fault-finding checklist you may give to the learners when they are working on their circuits. You can make it into a poster for the wall so that the learners can check the steps if their circuit is not working.

#### **Fault-finding if your circuit is not working:**

Electrical circuits should never really break - you can always fix them if you know how to do so! Here are some things to check when building a circuit or if your circuit does not work:

- Is the circuit made according to the circuit diagram? If not correct it to suit the diagram.
- Are the joins firm? Check them. Make sure they have proper contact. Make them secure.
- Is there a short circuit? This means that the connecting wires are touching. Attempt to fix it.
- Is there a break in the wire? Replace the wire or fix the break.
- Are the components connected the right way round? Check and change the way they are connected.
- Are the components working? Check the battery. Check each component with a metre or in another circuit.
- Are the values of the components correct? Check that the values of the components match what is needed for the circuit.
- Are the cells or batteries connected in the right way? Reconnect them correctly.
- Is the battery or cell strong enough and not flat? Replace the battery or cell.

If the circuit is still not working, go through these steps again.

## Week 3

### Lesson 6

The learners will work in groups to make a simple circuit. They will draw the circuit and demonstrate an electromagnet with a switch.

#### ACTIVITY 10 Electromagnets LB p. 106

Group

It is important that the learners see how to make an electromagnet because they must make one on their crane.

Here are eight easy steps on how to make an electromagnet:

1. Get a battery.
2. Find a large nail.
3. Get three metres of coated wire, such as telephone wire.
4. Neatly coil the wire around the nail in an even and uniform way.
5. Strip about 20mm off each end of the wire.
6. Use some vinyl electric tape to attach one end of the wire to the battery.
7. Find something like a paper clip and hold the electromagnet close to it. Show the learners how it will 'stick' to the electromagnet.
8. Show the learners what happens when you disconnect the wire from the battery.

You could make this into a poster with simple illustrations for each stage.

An **electromagnet** is a tightly wound coil of wire, usually with an iron core, which acts like a permanent magnet when current is flowing in the wire. When electricity is passed through the coil of wire, a magnetic field appears around the coil. This is **invisible**. If a piece of steel is placed inside the coil for a few minutes it becomes **magnetised**. When the learner switches off the electricity the soft metal will be a new magnet.

If they put something made of soft iron in the middle of the coil permanently and pass the electric current through it, it becomes an electromagnet. This can be switched on and off when they switch the electricity on and off.

The learners should use a soft metal because it loses most of its magnetism when the current is switched off. Metal, like steel, which is harder, does not lose its magnetism.

#### Hint

If any learners are battling to make a circuit, have a poster or drawing of a simple circuit on the chalkboard. Include the circuit diagram. Once the learners understand this simple circuit, and circuit diagram, they will realise that they should start adding the different components in the correct places and they will be able to make and draw more difficult circuits.



Remember that switching the current off causes the magnetic field to die away. So it is important for the learners to know how to make a simple switch for their electromagnet. See the examples of switches shown in the Learner's Book on page 110, after Activity 12.

Let the learners try out these switches or make one of their own from these ideas. You should photocopy these pictures and put them up on the wall for the learners to refer to when designing and making their crane.

### **ACTIVITY 11** Extension activity - Making an electromagnet LB p. 107

Group

If there is time in this one hour lesson, let the learners practise making an electromagnet or they may be given it as a homework task. You may collect pictures of electromagnets and also have an electromagnet that the learners can observe.

If the school has computers and Internet there are some wonderful sites which have step-by-step instructions on how to make an electromagnet. There are also videos of this process and it will make the lesson more interesting. Remember, if you see it you will remember it! The learners can also open the sites on their cell phones, under supervision.

Homework exercise: The learners should make a poster of the eight different steps used to make an electromagnet or they may download the video from the Internet onto a flash drive and then show it to the rest of the class.

### **ACTIVITY 12** Switches LB p. 107

Group

Not all schools have the resources to buy switches for their projects. It is important that they learn to make their own switches out of recycled or cheap materials. The learners should be creative and come up with ideas of their own which they should test and try out.

Refer to the ideas for switches illustrated on page 110 of the Learner's Book. You may photocopy these illustrations to give the learners some ideas about how to make their own switches out of waste and cheap materials.

You should collect different switches to show the learners. It is also important to make switches out of used and recycled materials. If the learners are creative they may change the ideas shown to them.

In a mechanical switch, a force has to be applied to bring together or separate electrical conducting metal contacts.

**SPST: single pole single throw (single pole on-off)**

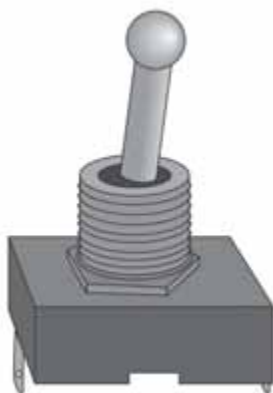







**ACTIVITY 13** Extension activity - Circuits  
LB p. 109

Individual

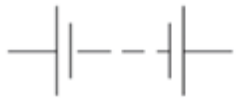
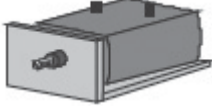
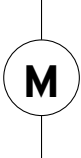
**Possible answers:**

1. The steps to build a simple circuit are: connect the cells. Connect insulated wires to the cells. Attach the insulated wire to the bulb, but if there is no bulb holder then attach one piece to the side of the metal part of the bulb and the other piece of insulated wire to the base of the bulb.
2. The learners should draw a circuit diagram of a simple circuit.
3. The learner's own words.
4. It becomes magnetised.
5. They will describe how they made their own switch.
6. The learners may include ways to improve their circuit such as: attach the insulated wire properly, make a cell holder, make a bulb holder, or make a switch to switch on and off.

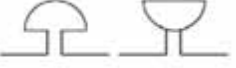
Draw the symbols for these devices:

Component		Symbol
Cells connected in series		
Motor		
Push switch		
Bell		
LED		

Ensure that the learners have completed the self assessment checklist on page 111 of the Learner's Book and discuss that with them.

## Unit 6.1 **Machines and mechanical advantage**

### Week 4

#### Lesson 7

Week 4 will be a two-hour lesson. At the end of each week the learner will have a self-assessment or peer assessment to revise the work they have covered in the two hours. The learners will learn about mechanical systems and strengthening frame structures. The learners will make combinations of simple mechanisms and explore mechanical advantage. This lesson will require revision on levers.

#### **Machines and mechanical advantage**

**Things the learners will need before they start Week 4 include:**

- Posters and articles that demonstrate mechanical advantage, such as people using a pulley system to remove a car engine.
- Examples of cranks and pulleys (use toys or old models from previous years).
- Wire, wood, sositie sticks, wooden wheels, string, glue or anything else used to make a crank and pulley.
- Sucker sticks or cardboard cut into strips to demonstrate triangulation.

#### **Machines and mechanical advantage**

All **mechanisms** use movement, which is also called motion. Mechanisms control force and motions so we have less work to do than without the mechanism.

Discuss the different things in the classroom that make our lives easier. Even something as simple as a fan keeps us cool. They might also have a pencil sharpener. Think about things in the home, such as a washing machine or an egg beater. Explain to the learners that anything that makes work easier for us gives us mechanical advantage.

## **ACTIVITY 14** Machines and mechanical advantage LB p. 110

Group

Place the learners into groups and ask them to discuss mechanical advantage. They can look at the illustration in the Learner's Book and find as many examples of mechanical advantage as they can. They can also use magazines and newspapers and cut out pictures of 'machines' that make our lives easier. Think about things like a lawnmower, compare it to a 'slasher' that is used to cut big areas of grass. They must think about the time that machines save us. Discuss the expression: 'Time is money!'

## **ACTIVITY 15** Revision - Levers LB p. 111

The learners should be reminded about the levers that they studied in Term 1, and that, in this term, a lever and a magnet will be combined to perform work. A lever is a simple machine or mechanism. Levers were most probably the first mechanisms to be used by humans when they were lifting heavy objects or opening shells. This could be made into a poster and labelled 'Simple Mechanisms'.

For revision remind the learners that a lever consists of a stiff bar or rod that turns around a fixed point called the pivot or fulcrum on which it rests. The effort (pull or push) is applied to the lever at one point in order to move a load at another point of the lever.

Here are the definitions that the learner should remember:

- Effort: the pull or push force
- Pivot or fulcrum: the point around which the load and effort turns
- Load: the object which resists or works against the pulling or pushing.

You may collect different items from around the home or at school to demonstrate simple levers. Some of the items that are easily found are: a screwdriver, can of paint with metal lid, tin opener, spade, scissors, bread knife and bread. You may also collect pictures from magazines.

### **First-class levers**

In a first-class lever the pivot or fulcrum is between the effort (the force trying to move the load) and the load (weight). The pivot or fulcrum can be anywhere in between the load and the effort.

This could also be made into a poster for you to photocopy and put up on classroom walls.

### **Second-class levers**

In a second-class lever the load is between the pivot or fulcrum and the effort.

**You may have a worksheet or give the learners a quiz on levers.**

**A pen and paper test for the learners on levers:**

1. Summarise:
  - a. effort
  - b. fulcrum or pivot
  - c. load
2. What will happen if you have a 1kg bag of sand on one side of the seesaw and a 1kg bag of feathers on the other side of the seesaw?
3. Give example of these levers:
  - a. First-class lever
  - b. Second-class lever
  - c. Third-class lever
4. What is a crank?
5. The learners will be asked to identify the different levers:
  - a. Someone digging with a spade
  - b. Pushing a wheelbarrow
  - c. Cutting paper
  - d. Slicing bread
  - e. Opening a bottle of soda
  - f. Opening a paint tin with a screwdriver

**Possible answers:**

1.
  - a. Pull or push force
  - b. The point around which the load and effort turn
  - c. An object that works against or resists the pulling or pushing force
2. They both weigh the same so the seesaw will be balanced.
3.
  - a. First-class levers – screwdriver, spade
  - b. Second-class levers – nutcracker, bottle opener, trolley with two wheels, wheelbarrow
  - c. Third-class levers – fishing rod, crane carrying something, a person cutting bread.
4. A crank is a bar that turns on a point.
5.
  - a. First-class lever
  - b. Second-class lever
  - c. Third-class lever
  - d. Third-class lever
  - e. Second-class lever
  - f. First-class lever

Even though the learners have not revised third-class levers it is good to include them in extension activities.

## **ACTIVITY 16** Extension activity - Second-class levers LB p. 113

Pair

The learners will be able understand the relationship between the position of the fulcrum, load and effort of the second-class lever.

If you are able to organise a wheelbarrow the learners can do this activity. This is a fun activity and you should encourage the learners to do it! If there is no time at school they may do it with friends as a homework exercise.

Work with a partner and investigate what the relationship is between the position of the fulcrum, load and effort in a second-class lever. Learners should write down their finding so that they can report back:

- Learner 1 sits at the front of the wheelbarrow and Learner 2 picks up and pushes the wheelbarrow. This is the easiest and most effective position for Learner 2 to push the wheelbarrow.
- Learner 1 sits in the middle of the wheelbarrow and Learner 2 picks up and pushes the wheelbarrow. This is less difficult and a more effective position for Learner 2 to push the wheelbarrow.
- Learner 1 sits at the back of a wheelbarrow and Learner 2 picks up and pushes the wheelbarrow. This is the most difficult and least effective position for Learner 2 to push the wheelbarrow.
- Which of the three positions was the easiest to push? The first one, where Learner 1 sits at the front of the wheelbarrow.

**Conclusion:** When the load is closer to the fulcrum the person using it will have the mechanical advantage and only have to use a small effort.

## **Week 4**

### **Lesson 8**

This lesson will introduce the learners to cranks and pulleys. There will be revision on mechanical advantage and strengthening frame structures.

## **ACTIVITY 17** The crank: an adaptation of a second-class lever LB p. 113

Individual

### **The crank**

Explain to learners that a crank is an arm that is attached to a rotating machine. The crank causes the rotating energy to become energy that moves back and forth. A crank is a type of second-class lever. Discuss the diagram of the second-class lever on page 115 of the Learner's Book. Talk about different types of cranes and their components.

## **The pulley: a type of wheel and axle**

Pulley systems are used in many everyday household machines, such as a sewing machine and washing machine. The pulley is also used to lift heavy loads.

A pulley is used to change the direction of a tension force. Multiple pulleys create mechanical advantage. A pulley is a type of wheel, but it does not have teeth like a gear. A pulley has a groove on its edge in which a rope, cable or belt can run. Pulleys transfer rotary motion from one axle or shaft to another. This helps to lift or move a heavy load.

A simple pulley system can be made with two wheels and a rope or elastic band which will work as a belt. The one pulley will be the driver pulley. This is the wheel that is turned and it drives or turns the other wheel. Both these pulleys will move in the same direction.

The learners could go outside with you and attempt to raise a heavy item off the ground using a pulley. Small metal pulleys are available in hardware stores. It is better that they experience working with pulleys in a practical way before trying to build their cranes. The learners can have a competition to see which group can pick up the heaviest weight.

Often learners in the townships make a pulley system without realising it. A simple rope thrown over a beam and a plastic crate tied on one side of the rope will pull up heavy loads onto their roof.

You can ask the learners at the end of the activity: What is a pulley? How can you achieve mechanical advantage using a pulley system with two pulleys?

### **Possible answers:**

A pulley is a wheel with a groove around the rim.

If the number of drops in pulley size is two, the effort in lifting the load will be halved, but the rope must be pulled twice the distance travelled by the load.

## **ACTIVITY 18** Revision LB p. 115

Group

### **What is mechanical advantage?**

Mechanisms exist to make life easier for us. A mechanism is a simple system which can change one kind of force into another and move that force from one place to another. All mechanisms use movement, which we sometimes call motion. They control a force so that we have less work to do than without the mechanism. The advantage that mechanisms give us over the efforts we have to make, is called mechanical advantage.

Discuss in groups: Can you think of a mechanism that makes your life easier?

If the learners do not complete the discussion in class they can do it as a short homework exercise.



**ACTIVITY 19** How can you strengthen a frame structure? LB p. 115

Group

**What is a structure?**

It is something that is built, made or put together in a particular way. It can be still, stable and strong and it can support loads. Some structures hold or support, others span or reach across a distance (like a crane) and other protect, enclose or contain. A frame structure is a structure that is made up of different parts.

Look at different structures around the school and discuss what kind of structures they are. At this point you can revise solid, shell and frame structures. Collect pictures from newspapers and magazines.

Discuss how some old bridges have been standing for hundreds of years. Look at the designs that were used. Collect pictures of frame structures from magazines.

Look at the different structures below and record the different ways they are reinforced.



Discuss the ways that have been used to make the structure sturdy.

Triangles are rigid shapes and do not easily change their shape. They are often used to strengthen structures. Look at the photos of the

bridges in the Learner's Book. Can you see which bridges have been built using triangulation? You can refer the learners back to structures in Term 1 for them to revise this section. Beams and columns support a frame structure.



Ties and struts will also hold up a structure and support it.

Trusses are often used to obtain long stable structures. A truss is a flat framework of beams which form a series of triangles. An example of this is a frame.

**Extension:** Make posters of different types of frame structures. The learners can also download information from the Internet (if available).

### **ACTIVITY 20** Revision LB p. 117

Individual

The learners will do a quick revision test in their exercise books for self-assessment.

#### **Possible answers:**

1. A first-class lever is when the pivot (fulcrum) is between the effort and the load. The pivot can be anywhere in between the load.
2. A second-class lever is when the load is between the pivot or fulcrum and the effort.
3. A crank is an adaptation of a second-class lever.
4. A pulley works like a wheel and axle.
5. Mechanical advantage is when a machine makes our lives easier. It is when a machine controls a force so that we have less work to do.
6. Different ways to strengthen a frame structure (see Module 2).

It is important that the learners know what their PAT is from the beginning of the term. It is good to have the end in mind. They will be able to relate to the different lessons and where the lessons are heading.

Learners complete the Self-assessment checklist on page 119 of the Learner's Book.

## Formal Assessment Task

### PAT 1

Make sure the learners have read the scenario and understand it!

Short Practical Assessment Task: PAT Crane with electromagnet 70%
Background: Problem scenario: A scrap-metal dealer sorts magnetic and non-magnetic metals into separate piles for recycling. The simplest way to do this is to use a crane with a magnet BUT it is difficult to remove metals that stick to permanent magnets. It would be beneficial to have a magnet that can switch on and off.
NOTE 1: The model cranes should be made using simple materials like paper dowels or elephant (thatching) grass. Sufficient strength and rigidity should be achieved by triangulation. Measuring and simple tool skills must be developed. Safe, cooperative working is a key skill and is needed in the world of work.
NOTE 2: The electromagnet will be strongest if a long insulated wire is used. Wire over 100mm long is very effective. The wire should be wound around a 'relatively soft' iron core. Avoid using a steel bolt (it is far too hard). A fairly soft core can be made using a bundle of short lengths or wire. Nails are softer than bolts but are still fairly hard. Increasing the current by using more cells in a series battery has a small influence on the strength of the electromagnet.

Discuss this table with the learners. It is set out so that they can see what is required of them in the PAT. They will have a quick overview!

<b>TOPIC</b>	Electrical systems and control/structures/mechanisms
<b>CONTEXT</b>	Recycling and Impact
<b>CONTENT</b>	Structures and electricity and cranks and pulleys
<b>DESIGN AND MAKE</b>	<p>A crane using an electromagnet to sort metals</p> <p>Investigation skills: Case study</p> <ul style="list-style-type: none"> <li>• Design skills: design brief, sketch, draw a circuit diagram</li> <li>• Making skills: working model - electromagnet, crane</li> <li>• Evaluation skills: develop rubric, evaluate against</li> <li>• Communication skills: draw, revise, flowchart, team planning, presentation - posters</li> </ul>

Here is a reminder for the learners about how to go about the design process. You can make this table into a poster so the learners can refer

back to the chart while doing the PAT. Remind the learners that the design process is not linear, usually cyclical. It is driven by evaluation. Evaluation at each stage determines the next step.

<b>The Design Process</b>	
Investigate	Problem/need/want Context/impact Research/questionnaire/interview Materials/suitable tools/required skills
Design	Initial ideas Freehand sketches Design brief with specifications and constraints Plan using systems diagram Trial modelling Budget
Make	Choose tools/method/materials/resources Draw formal plans Draw flow charts/sequence of manufacture Make prototype/model/final product (considering safe working procedures)
Evaluate	Evaluate severity/urgency of problem/need/want Analyse solution using a systems diagram Evaluate solution in terms of design brief, specifications and constraints Evaluate product/process/manufacturing method/safety Evaluate impact/bias/an indigenous solution
Communicate	Report Present Advertise/poster/using artistic graphics

Checklist (a copy should be given to each group so they know what they are being assessed on!)

<b>DESIGN BRIEF</b>	<b>YES</b>	<b>NO</b>	<b>COMMENTS</b>
Problem was stated in simple sentences			
Solution was described simply			
<b>The function of the product is described</b>			
Type of crane			
Height of crane			
Type of crank or pulley system			
Type of switch for magnet			
The user was described			
The context was described			
<b>SPECIFICATIONS</b>			
Were there specifications with regard to features?			
Were there specifications with regard to the electromagnet and crane?			
Were there specifications with regard to attractiveness of design and use?			
Were there specifications with regard to durability?			
<b>WORKING DRAWING</b>			
3-D oblique drawing techniques			
Drawn on squared paper (quadrant) using a pencil and ruler			
Appropriate scale			
Line types and dimensions			
Flow chart detailing the sequence of manufacture			
<b>MAKING SKILLS</b>			
Used simple materials			
Model able to pivot or to raise and lower its arm			
Electromagnet with a switch			
A light on electromagnet to show if it is on			
Electromagnet made with correct materials			
<b>EVALUATION SKILLS</b>			
Ability to evaluate a product or process			
Developed a rubric to evaluate the models of other teams			
Used their rubric to evaluate			
Assessed objectively, fairly and made valid comments			
<b>COMMUNICATION SKILLS</b>			
Strategy to present model and plans to class			
Ideas and roles by each member indicated			
Presented sketches, working drawing and function of model			
Demonstrated how well model works			
Explained principles of magnetic sorting			
Commented on value of recycling and explained sorting of metals			
Enhanced presentation with posters giving an artist's impression			
Poster of electromagnet in use			

**Some of the materials needed for the PAT:**

- Magnets
- Paper dowels, elephant grass (thatching), strong cardboard
- Wood glue
- Nails
- String
- Wire
- Soft iron
- Strong insulated wire
- Something to make switch, cells
- Something to measure with
- Some simple tools like junior hack saw, hammer
- Pencils, rulers, erasers and paper

**Remedial tip**

Learners with a barrier to learning should be put together with someone in a group who can help them. It is good for them to find a 'buddy' who will work well with them. They often have skills that will help the able learner! Make sure that the learner who has a low reading age is put into a group with a strong reader. Slower readers must not be used for writing but may be good at drawing. They can then follow instructions from the stronger reader.

Remember for the short practical assessment you need to encourage the learners to be innovative, creative and use their problem-solving skills. The ability to think laterally so they can develop original and appropriate solutions is a key element in technology. The learner should be able to investigate, demonstrate the ability to draw with a design brief, give specifications and constraints, select appropriate materials, plan, evaluate, analyse and communicate.

Make sure that the learners have sharpened their pencils for their designs. Remind them to add their circuit diagram to show how the electromagnet is going to work.

**Week 5****Lesson 9**

The learners will do a Case Study with pictures of cranes. This lesson will include a design brief with specifications and constraints for a crane with an electromagnet.

### **Remedial tip**

Learners with reading disabilities will find this written part (design brief) of the design process difficult. It is important that you or a strong academic learner help these learners. You could also have a special 'Technology dictionary' with words often used in the Technology class along with the tools and materials available. Allow the slower learners to write shorter sentences. You might also have to give them extra time. You should tell them that they will not lose marks for poor spelling. You should also have all the tools and materials marked with large letters for the learners to copy. Allow the learners to have their exercise books in front of them to copy different works for circuits.

## **ACTIVITY 21 and 22** Cranes and the design process LB pp. 119-120

Group and Individual

### **Case Study**

The learners will discuss different pictures of cranes. Encourage them to identify the different parts, such as the pulley system. You can give the work that is not completed in class as homework. Encourage the learners with Internet access at home to do some research and even print out pictures that they have found on the Internet.

#### **You will need:**

- Posters or drawings of designs done using single vanishing point perspective
- Examples of circuit diagrams and symbols
- Pencils and design paper

The learners can also take home some examples, of drawing vanishing point perspective to practise for the test.

## **Week 5**

### **Lesson 10**

The learners will continue with their design brief. They will also draw a circuit diagram for the electromagnet.

## **ACTIVITY 23** Circuit diagrams LB p. 120

Individual

The learners need to revise the circuit diagram and how it corresponds to an actual electrical circuit. They should draw their own circuit diagram.

## **Week 6**

### **Lesson 11**

The learners will revise the 3-D oblique drawing technique, line types, scale and dimensions. They will also practice the oblique drawing technique on squared paper. They will also work out a flow chart.









## ACTIVITY 24 Revision of 3-D oblique drawing LB p. 122

Individual

### 3-D oblique drawing, lines, scale and dimension:

The learners will revise communication using techniques taught in Module 1. They learnt how to communicate the 3-D oblique technique with 45 degree projection to scale the correct line types and dimensions. The learners are expected to use the correct drawing ideas. The modules before should have helped them develop their drawing skills.

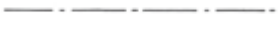
You can make this chart below into a poster for the learners to check when doing their drawing:

Description	Drawn line	General application
Continuous thick line	A 	Visible outlines Visible edges
Continuous thin line (straight or curved)	B 	Imaginary lines at intersection Dimension lines Projection lines Leader lines Hatching Outlines of revolved sections in place Short centre lines Bending lines
Continuous thin – freehand	C 	Limits of partial or interrupted views and sections, if the limit is not a chain thin line
Continuous thin (straight) with zigzags	D 	Break line
Dashed thick	E 	Hidden outlines Hidden edges
Dashed thin	F 	Hidden outlines Hidden edges
Chain thin	G 	Centre lines Lines of symmetry Trajectories
Chain thin, thick at ends and changes of direction	H 	Cutting planes
Chain thick	I 	Indication of lines or surfaces to which a special requirement applies

### Did you know?

A 3-D drawing is a pictorial view of an object. It shows three sides of an object.



## ACTIVITY 25 Revision of oblique projection

LB p. 123

**Oblique projection** uses graphical projection and is a two-dimensional image. The object that is drawn is three-dimensional. It is important that you are able to draw an oblique projection before teaching this method to the learners. An oblique drawing is another form of pictorial representation. One face or side of an object is drawn in its true shape and the other part of the object is drawn sloping away. All oblique drawings have three axes. One is vertical, one horizontal and one is an incline axis. The sloping lines are drawn at any convenient angle. This drawing will be drawn at a 45 degree angle for this module.

The easiest way to teach the learner how to draw the 3-D oblique drawing is to start with the front view then draw the angles backwards at 45 degrees to the horizontal base.

### Tip

Try drawing in freehand first. It is important for you to demonstrate this to the learners. If the learners are taught to draw the side of the matchbox and from the horizontal base backwards from the side at a 45 degree angle they will be drawing a 3-D oblique drawing of the matchbox. Take the learners through the demonstration step by step.

Demonstrate each construction step by step using the correct tools and techniques such as rulers, compasses and construction lines. Once you have demonstrated this allow the learners to practise the technique as a homework exercise.



## ACTIVITY 26 Revision of scale LB p. 124

Individual

## ACTIVITY 27 Revision of dimensions LB p. 124

Individual

## ACTIVITY 28 Drawing the design LB p. 125

Individual

Drawing the 3-D oblique drawing on quadrant paper: The learners will draw their ideas on the squared paper. They are going to draw their final design from the two sketches from the previous week. They must make sure it is neatly drawn and drawn to scale.

Make sure the learners have their squared paper (quadrant) and that they use a pencil and ruler.

## Week 6

### Lesson 12

The learners will look at the sequence of manufacture of the crane with its electromagnet.

#### **ACTIVITY 29** The flow chart LB p. 125

Individual

The learners already have some idea of how a flow chart works.

#### **Things you will need:**

- Have a poster with the different line types. (See table in above)
- Pencils and ruler
- Squared paper (quadrant)
- Examples of flow charts (This is to remind learners about how to present their flow chart.)

Make sure this part of the design is done before they move on to actually make the model.

#### **Flow charts:**

Put some examples of flow charts on the wall of the classroom, showing designs for other projects. Show them that it is important to have as much detail as possible. This will help them build their model and they will know exactly what they are doing and at what stage they need to do it.

Remember during all these processes you should observe whether the learners have mastered the techniques or not, and to see if they have taken all the different aspects into account.

## Week 7

### Lesson 13

In this lesson the learners will make an electromagnet. The learners in the group must be encouraged to look objectively at the designs of the other learners in their groups, when choosing the final design.

In Week 7 they are going to make their electromagnet using an electrochemical cell. They should look back on this module to find the electrochemical cells they can use and guidance about how to make an electromagnet.

#### **ACTIVITY 30** Making an electromagnet LB p. 126

Group

The learners have watched a demonstration of how an electromagnet works. They have drawn the circuit diagram for an electromagnet and had a chance to make their own electromagnet.

They must be reminded about the switch, as their electromagnet must be able to switch on and off to drop the metal it has lifted with the crane.

## Week 7

### Lesson 14

#### **ACTIVITY 31** The structure of a crane LB p. 127

Group

The learners will work safely on their model cranes, that will have a crank and pulley system. They must keep to their design. If they decide to change something on the model they must make sure they change it on their design first. You must make sure that the learners have all the materials and tools they need for making their model before they start working in their group. Remember that each member of the group must have a 'job' to do.

During this process you should walk around and observe the construction of the model. It is also important to watch the interaction of the learners and what role they play in their group dynamics.

## Week 8

### Lesson 15

It is good for the learners to learn how to evaluate the work of their peers.

This week they need to critically evaluate a product, namely their design against the criteria that they will follow to develop their project. They need to develop the process further and develop a rubric to evaluate the models of other teams. The learners also need to be critical of the other teams' work so that the evaluation is objective rather than subjective.

#### **ACTIVITY 32 and 33** Criteria for assessment LB p. 128

Group

Teach the learner how to evaluate their product. They have to be objective. They must see that all the requirements are met.

You should remind the learners that the requirements or specifications that the learners were given should be used for the evaluation.

## Week 8

### Lesson 16

The learners need to evaluate the models of the other teams, and develop a strategy to present their model and plans to the class.

#### **ACTIVITY 34** Assessment of other groups

LB p. 128

Group

Give the learners examples of rubrics. See the front of the book. Based on the examples they will be able to develop their own rubric to assess the other groups.

## Week 9

### Lesson 17

The learners need to present their design sketches, working drawings and functioning model to the class.

#### **ACTIVITY 35** Group presentations LB p. 128

Group

When the learners start this section on communication, make sure they have all their papers and material that they used to design and make their model. 'The better the presentation the better the marks' – explain this to the learners. They must also make sure that each member of their group works on his or her individual section and then they can all work together following this. They should make themselves a check list like the below:

#### **Check list:**

- Working notes
- Design brief
- Sketches
- Flow charts
- Plans
- Posters
- Model
- Any research they did
- Books they may have used.

## Week 9

### Lesson 18

Each learner needs to explain the role they played. The groups need to enhance their presentation using visual aids. Although the learners have communicated their investigation and design throughout the design process by drawing, writing and discussing their design, it is important that they record the entire technological process in their exercise books.

## **ACTIVITY 36** The roles of each learner LB p. 129

Group

Learners must explain the role they played in their group, such as discussion monitor, assessor, time keeper, record keeper, reporter, and other roles.

Encourage the learners to enhance their presentations by having as many posters and related material as possible. They must make sure they are clear, neat and colourful!

## **Week 10**

### **Lesson 19**

#### **Revision**

This lesson will test all of the knowledge gained in Term 3.

## **ACTIVITY 37** Revision activities LB p. 129

Individual

There are different questions and worksheets for you to use to test the learners knowledge.

You can photocopy the tests in Section E. They range from easy to fairly difficult. Select the questions and make up your own test (remember that 60% of the test should be easy so most of the learners gain some points).

## **Week 10**

### **Lesson 20**

#### **Peer assessment checklist**

## **ACTIVITY 38** Formal assessment task LB p. 129

Individual

Formal Assessment: Term 3	Weighing: 10% of promotion mark
PAT (70%)	Summative test: {30%} Total: 100%



**Practical assessment task**

The PAT for this term deals with tragic shack fires or natural disasters like floods or earthquakes or political strife that may create the need for emergency shelters for victims of disaster. Learners will design and make a simple emergency shelter for disaster victims. The shelter must be sturdy, waterproof, easy to erect and able to house a family of six for one month.

The module this term deals with processing. Learners will investigate various emergency situations that lead to people becoming refugees and the needs that arise from these situations. Technology is a learning area that deals with practical solutions to solve problems. The learners' task at the end of this module is to use the knowledge and skills gained to make a model of an emergency shelter that will be suitable for people to use in an emergency situation. The answers to the sequence of work that needs to be followed are provided below.

Here is an analytical rubric to assess design capability in the PAT at the end of this module:

<b>The learner is able to:</b>					
<b>LEVELS OF COMPETENCE</b>					
	<b>Exemplary</b>	<b>Competent</b>	<b>Developing, but not yet mastered</b>	<b>Progressing</b>	<b>Progressing</b>
	<b>5</b>	<b>4</b>	<b>3</b>	<b>2</b>	<b>1</b>
<b>Generate and develop design ideas</b>	Using drawings reflectively to generate new ideas	Progression of ideas across or within drawing	Design ideas are generated but not developed	Simple sketch showing object to be made	Drawing a picture not designing a product
<b>Explore the possibilities of the problem/ the need</b>	Combining novel solutions to produce innovative design	Using drawings to develop novel design solution/s	Recording possible creative solution/s to the task	Stereotypical response, showing little creative thought	Design possibilities are not addressed in the drawing
<b>Address the constraints of the problem/need</b>	Task constraints treated as part of iterative process	Task constraints considered as the design proceeds	Records way to address task and/or client needs and wants	Drawing show some understanding of task constraints	Minimal understanding of task/user needs
<b>Plan the look of the product</b>	Ideas about finishing are developed within overall designing	Ideas about finishing are added to design while drawing	Overall decoration scheme considered	Little consideration of final appearance of product	Appearance of the product is not considered
<b>Communicate design ideas</b>	Clear enough for somebody else to make the product	Conveys sense of the object to be made e.g. working drawing	Conveys some sense of the object to be made e.g. indicates the materials	Simple unlabelled sketch(es); relying on shared meanings	Use of narrative or other drawing genre
<b>Plan construction</b>	Constructional issues considered on route to final design	Drawing demonstrates consideration of construction	Drawing indicates some consideration of construction	Minimal consideration of construction while drawing	Yet to define the design task
<b>Evaluate while drawing</b>	Changes made as a result of considering design drawings	Decisions made about product while drawing	Considered and rejected a range of designs	Minimal evaluation at drawing phase	Yet to define the design task
<b>Provide a basis for making</b>	Using drawings as a resource during making	Clear development path through drawing into making	Object is one of the ideas drawn	Product relates to ideas recorded in the drawing	Making an object seen as separate new activity

Comments to improve the learners' performance in design capability:



## Unit 7.1 Investigation skills

### Week 1

#### Lesson 1

Learners investigate emergency situations that lead to refugee situations.

#### Learning activities:

- Discuss emergency situations that lead to refugee situations.
- Discuss case studies on different types of refugee situations.
- Written Activity: Tabulate information from case studies for the learners to complete in their exercise books.
- Written Activity: The learners need to develop their own mind map.
- Vocabulary extension

#### Assessment:

- **Informal Educator Assessment:** check the completion of tasks

#### ACTIVITY 1

#### Investigate what situations commonly lead to people becoming refugees LB p. 132

The learners need to redraw the following table in their exercise books. They need to **tabulate** the the four case studies' situations according to whether or not they are classified as natural disasters or refugee situations. Reasons must be given for the tabulation.

#### Suggested Answers:

Accept results as given in each case study and from the class discussion.

Natural Disaster	Refugee Situation	Reasons	Results
Case Study 1		Caused by floods	
	Case Study 2	Caused by civil war	
Case Study 3		Caused by fire	
	Case Study 4	Forced to flee for fear of political persecution	

## Week 1

### Lesson 1

#### **ACTIVITY 2** Initial problems typically faced by refugees LB p. 134

This activity will look at the mix of people present in a refugee situation. It may be used as a homework activity for slow learners or as an extension activity for accelerated learning.

You can do a vocabulary extension at your discretion.

New words and phrases should be discussed, written on the board, taken down in exercise books or put up around the classroom.

#### **Focus: Investigation**

#### **Learning activities:**

- Learners should investigate famous refugees
- Learners investigate situations in a refugee camp
- Discussion
- Written activity to be completed in exercise books
- Self assessment task

## Week 1

### Lesson 2

#### **ACTIVITY 3** Discussion and summary writing LB p. 136

People in a refugee situation have a variety of needs. Identify the problems that are experienced by refugees and give an example of how they have tried to solve these problems.

Accept all answers from the learners. If the answers are not clear then ask for an explanation. Encourage the learners to empathise with refugees and come up with answers of their own to the problems. This particular activity should include mind maps, tabulation of information and summary writing.

## Unit 7.2 Emergency food

### Week 2

#### Lesson 3

##### Focus: Investigation

##### Learning activities

- Learners investigate the types of food that can be supplied to occupants in a refugee camp
- Learners collect and record information regarding suitable food that can be supplied to people living in a refugee camp
- Written activity: completion of research worksheet – to be stuck into exercise books
- Learners use information collected in the next lesson

##### Assessment Task/s

- Educator – informal assessment – observation of completion of tasks

**Additional Resources:** Worksheet 1: Investigative Task Worksheet

It is necessary to provide emergency foods to the occupants of a refugee camp.

##### Learning activities:

- Group work
- Discussion
- Research Homework Activity

##### Additional Resources:

The learners will do a worksheet on Group Dynamics which will be a group investigative task.

#### **ACTIVITY 4** Group Investigative Task: Type of food that can be supplied to occupants in a refugee camp LB p. 138

Group

1. Arrange learners in groups of suitable numbers.
2. Hand out copy of the investigative task worksheet found in the Appendix. Ensure that all learners have a copy of the worksheet.
3. Use the first fifteen minutes of the lesson to allow learners to discuss the type of food that they think should be served to people at a refugee camp.
4. Learners write down a list of food to be researched on the investigative task worksheet.  
Explain the criteria to learners. Discuss an example, such as brown bread. This needs little preparation, it is cheap, readily available, can feed a reasonable number of people, has no cooking requirements

and does not need to be stored in a fridge. Learners can therefore decide to make simple sandwiches to feed refugees.

7. Learners use the rest of the lesson to discuss how they are going to conduct their research and delegate duties to group members.

Learners investigate the types of food that can be supplied to occupants in a refugee camp.

The aim of this investigative task is to give learners an opportunity to gather information regarding suitable foods that are most easily cooked when living in a refugee camp. Learners need to research information according to the subheadings (guidelines) outlined in the research worksheet. They may however choose to include or delete aspects and add on their own subheadings.

In this way learners are able to make an informed choice regarding their choice of food to prepare instead of just cooking a food out of convenience.

### **Learning activities:**

- Discussion
  - Individual research task
  - Tabulation of information
  - Group Activity
  - Take the first 15 minutes of the lesson to allow learners to discuss and write down the food that they think is suitable to prepare for people living in a refugee camp.
  - Allow learners to discuss the information that needs to be collected for each food mentioned on their list.
  - Allow learners to add or delete criteria.
1. Divide learners into suitably sized groups.
  2. Hand out the research worksheet.
  3. Explain each aspect of the worksheet and what learners are expected to do.
  4. Give learners time to discuss in their groups what they consider the five most suitable types of food that are most easily served as a meal in a refugee camp.
  5. Learners are to write down their list of chosen foods under the column 'Suitable food to be cooked for people living in a refugee camp'.
  6. Learners are to investigate each of the foods listed to determine how suitable each food is to prepare in a refugee camp.
  7. Learners record information on the research sheet provided.
  8. The research sheet needs to be stuck into the Technology exercise book and discussed in the next lesson to allow learners to make an informed choice regarding the type of food their group will prepare.

Learners are to bring their research information to the next lesson so that they can discuss information gathered and then make an informed choice regarding one type of food to prepare. Imagine that you are a refugee. Work in groups and look at the list of items below. Your group is only allowed to take ten items with you. Rank the items according to the importance of what you would take. Start with the most important item at the top. Report back to the rest of the class, and state the reasons for your choice of items.

List of items:

Cell phone, play station, schoolbooks, blanket, pillow, disinfectant, matches, lighter, pot, tooth brush, phone card, can opener, knife, compass, can of food, knapsack, pet, one photograph of the person most important to you, a plastic sheet and an iron pot.

Procedures for this activity include:

- Refer to the activity on group dynamics.
- Divide learners in the class into suitable size groups.
- Hand out a copy of Appendix 1 on the role of different people in a group.
- Allow learners to allocate roles to different members of the group.
- Allow a 15 minute discussion session for learners to rank their items.
- Have a report-back session.

Guide learners regarding the following issues. You may do this either at the beginning of the lesson if you think that more direction is needed, or after the report back session if it is a group of high achievers:

- The situation at hand (you are a refugee)
- The basic needs of people
- The difference between needs and wants

Suggested ranking order should be according to the fulfilment of basic needs, such as:

Food: a can of food, a pot in which to cook food, a lighter to start a fire to cook the food, heat water and to keep wild animals away at night. A fire will also give warmth.

Shelter: plastic sheet, blanket

Needs: can opener, pillow, torch, batteries

Things that are not essential but that are nice to have: a compass for direction, matches in case the lighter runs out, and disinfectant.

## Week 2

### Lesson 4

#### **ACTIVITY 5** Points to consider before you start preparing a meal LB p. 139

There are several points that the learners should consider before they start preparing their meal.

Learners use the information collected from the investigative research task to discuss and come to a consensus regarding the type of meal that should be prepared. Learners discuss problems that are associated with the preparation of the meal and safety concerns. Learners write a design brief and list ingredients and equipment needed for the preparation of the meal.

This should be a class discussion about report writing.

Hold a class discussion and come up with a list of ten items that you agree would be of most importance in a refugee situation. Write a short report from your discussion on 'Conditions under which refugees live'. Also consider the ingredients of a meal that will be nutritious as well as tasty and which can be prepared under conditions likely to be found in a refugee camp.

Learners should discuss these questions in their groups:

1. All the things that refugees have been provided with  
Very little – Temporary shelter plastic utensils, promise stove or may need to cook on an open fire.
2. The basic necessities they don't have that make the task of cooking a meal, easy.  
Suitable stove, electricity, large utensils, hygienic cooking conditions
3. Your safety concerns  
Cooking on an open fire
4. Choose a food that your group thinks is the most suitable to prepare  
Learners own choice  
Complete the following tasks in your exercise book.
5. Write a design brief with specifications of the type of food chosen.  
I need to plan and prepare a simple meal that can feed 100 refugees living in a refugee camp.
6. List the ingredients needed to prepare the meal for 100 people  
Will depend on the learners choice of meal
7. List the equipment needed to cook this quantity of food  
Cutting utensils, chopping board, dishes, pots, three-legged stand if using an open fire

Accept other suitable answers

Some guidelines:

- Reports serve to inform people about situations
- Explain any terms used
- Give facts
- Do not include personal opinions
- Avoid the use of personal pronouns (refer to the refugee as 'refugee' rather than he or she. Use words such as 'one' can say that instead of he or she.
- A report is an example of formal writing and it needs to sound professional
- Make recommendations

The group discussion should get the learners to consider the problem and design a solution in which they consider:

- Conditions under which refugees live
- Safety concerns
- Factors that need to be considered when planning a meal to feed refugees

Individual Task:

- Write a design brief
- Plan a meal
- List ingredients and equipment needed to prepare a meal for 100 people
- Evaluate design briefs
- Choose the best solution and make an informed choice
- Draw up assessment rubrics

### **Extension Activity: Random Act of Kindness (RAK) Moment**

As an extension activity, the learners should post their RAK moment on your school website or on social media and challenge other pupils to help feed those in need.

## **Week 3**

### **Lesson 5**

#### **ACTIVITY 6 The sequence of manufacture for preparing a meal LB p. 140**

The learners need to write down the sequence of manufacture for the process of preparing one item from the meal discussed above. They then need to prepare a meal.

In this lesson you should recap and explain the design brief (learners need to state what the problem is and what they think a suitable solution to the problem would be).

A design brief should answer some or all of the following

questions. Also consider other relevant information:

**Who** does the problem involve?

**Where** are the refugees?

**What** is the situation refugees are faced with?

**When** are you going to assist them?

**How** are you going to assist them?

What specifications must be considered when cooking the meal?

- Learners evaluate each design brief in the group using objective criteria
- They should choose the most appropriate design brief or make up a new brief by combining information from the different design briefs.
- Draw up an assessment rubric for the evaluation of the meal.
- They should report back.
- There should be agreement of common criteria by which meals by all groups will be evaluated in Lesson 5.

For suggested criteria for the design brief, refer to Appendix 1.

For suggested criteria for the evaluation of the meal, refer to Appendix 2.

## Week 3

### Lesson 6

The learners need to evaluate the meal in terms of flavour, texture and nutritional value.

#### Focus: Making and Evaluating Skills

#### **ACTIVITY 7** Prepare the meal LB p. 141

Group

Ensure that the learners have a rubric and keep their design brief and list of details in mind, as they prepare the item for the meal.

**Reassert that this** activity will be judged on the criteria set out in the rubric discussed.

#### **ACTIVITY 8** Evaluate your meal LB p. 141

Group

Learners cook and evaluate a meal

Assessment Activities:

- Educator Assessment
- Peer Assessment (Taste Panel –Extension Activity)

Assessment Tools / Assessment Methods :

- Observation – Assessment rubric (Appendix 2)
- Taste Panel – Rating Scale



- Self -Assessment Task (Homework Activity)

Additional resources needed:

- Educator – Assessment Rubric
- Learners – Rating Scale for judges on Taste Panel
- Cooking Utensils (provided by members of each group)
- Suitable cooking apparatus (to be decided on by individual school)

**Groupwork activity:**

- Learners cook meal in the allocated time
- Educator observes and scores learners
- Set up a taste panel to score meals according to established criteria (extension activity )

## Unit 7.3 Investigate clothing worn by people in specialised occupations

### Week 4

#### Lesson 7

The learner needs to investigate different clothing worn by people working in emergency situations.

**Focus: Investigation Skills**

#### **ACTIVITY 9** Uniforms LB p. 143

- A: Fireman
- B: Policeman
- C: Nurse
- D: Soldier in the army
- E: Emergency Rescue Services
- F: Doctor

Learning activities:

- Learners should investigate and draw up a list of local emergency facilities and contact numbers.
- Discussion and report back Activity – Personal Safety
- Poster Making – How to make sure of your personal safety (Extension / homework Activity).

Assessment Activity:

- Informal assessment – You should check and correct the research activity
- Formal assessment Task – Assessment of poster (Optional )

Additional Resources:

- Pencil crayons or koki pens and chart paper

Suggested emergency facility services and numbers should include:

- Police
- Fire Department
- Ambulance
- Medical Emergency Rescue Services
- SAPS Crime Stop
- Poison Information
- Contact numbers of individuals that should be contacted in the event of an emergency (Mom / dad / grandparent / work numbers / family doctor etc.)

Suggested information needed when making an emergency call:

- Name
- Address
- Type of emergency
- Report what the emergency is

## Week 4

### Lesson 8

The learners need to find out what textiles are used to make clothing worn by fire-fighters, and also what textiles are used to make clothing worn by members of the NSRI.

#### Focus: Investigation Skills

#### **ACTIVITY 10** Protective clothing LB p. 146

Learners need to investigate clothing worn by individuals working in emergency situations.

1. Redraw the following table in your exercise book.
2. Use the fact file on 'Clothing worn by firefighters' and the illustration showing PPE to help you complete the table.
3. As a homework activity you should research and find out the names of textiles used to make each of the items of clothing listed in the table.

Item of clothing	Purpose	Name / type of textile used to manufacture item
T-shirt	Protection from heat / keeps the firefighter cool	Cotton
Turnouts	Protection from hazardous elements / easy to put on in a hurry / place for equipment needed	Aramid fibres e.g. Normex and Kevlar
Reflective strips	Easy to see at night	Vinyl
Outside layer of pants	To protect fire fighter	Normex / Kevlar
Inner layer of pants	Provides protection from thermal heat	Fabric that is treated with fire-resistant chemicals to resist heat and flames
Hood	For protection	Normex
Gloves	Protect fireman's hands from flames and heat / allows fireman to hold hot and hazardous elements	Leather and fire retardant fibers e.g. Normex and Kevlar

4. Identify the similarities and differences between the firefighter's uniform and the personal protective equipment worn by essential workers.

Both need to wear protective face masks.

As with the coveralls worn by firefighters, PPE gowns and aprons worn must be easy and quick to put on.

For both, pockets need to be attached to carry needed equipment. Some of the PPE worn by essential workers are disposable, while this is not the case with the firefighters' uniforms.

5. Write down three rules that all people need to follow to prevent the spread of viruses.

Keep a safe distance of at least 1.5 m from others.

Wear a face mask and/or visor.

Wash and sanitise your hands as often as possible.

### ACTIVITY 11

### Extension activity LB p. 146

#### Crossword Puzzle

##### Across

- Pants that are turned inside out with the boots attached (Turnouts)
- Made of heavy duty leather and a Nomex lining (Gloves)
- Type of strip that makes the fireman more visible in the dark (Reflective)

##### Down

- Fire-resistant material (Nomex)
- Type of fastener that makes the uniform easy to close (Velcro)
- Has words and numbers that gives information about the fire department to which the fireman belongs (Helmet)
- Helps protect the lower body (Pants)

## Week 5

### Lesson 9

The learners need to examine building materials used by indigenous people in rural South Africa.

#### **ACTIVITY 12** Building materials LB p. 148

Learning activities:

- Identify and tabulate the materials and building techniques used by indigenous people in South Africa
- Discuss the PAT
- Plan the PAT

Building materials

Table of indigenous houses:

Indigenous people	Province	Shape	Materials	Building techniques	Impact on the environment
Xhosa	Eastern Cape	Dome-shaped/ beehive shape / round rondavel	Cow dung, grass, poles, thatch, rope made of grass		
Venda	Limpopo	As above	As above		
Sotho	North West Province	As above	As above		
Ndebele	Northern Province	Trapezoid	As above		

Building Techniques: (This is the same for all rural homes.)

This consists of a simple framework made of tree poles and mud bricks plastered with mud.

The roof is conical in shape and made of thatch and sewn on to wooded branches using rope made from grass.

Floors are usually smeared with cow dung

Built using hands and feet.

Impact on the environment: (Same for all)

Has a negative impact on the environment. Usually made from readily available materials found in the environment e.g. grass used as thatch for roofs, branches used as poles for framework – this leads to nature being destroyed and used as building materials. This can also lead to soil erosion. No proper service delivery in the area and these results in no running water, so rivers are being polluted because water is used for the washing of cars, bathing and the washing of clothes. No waste removal facilities results in pollution in the area.

- Discuss the background scenario in preparation for the PAT.
- Divide learners into groups for Lesson 14 to allow learners time to organise and plan the building of the model of the emergency shelter.

## Week 5

### Lesson 10

The learners need to explore the building materials used by migrant workers in informal settlements.

#### Focus: Investigation Skills

#### **ACTIVITY 13** Informal settlements LB p. 149

##### Learning activities:

The learners need to do a written task on the case study on informal settlements. They also need to complete a poster on recycling.

Assessment tools and techniques:

Observation: completion of tasks

Rubric: Assessment of poster (optional)

Suggested Answers:

(A) Overcrowding, lack of facilities such as electricity, water, sanitation, security, inaccessibility because of a lack of roads esp. in emergency situations. Fire hazard because of materials used for building, pollution, spread of diseases because of a lack of sanitation, running water and no refuse collections, unemployment, houses being swept away or damaged in harsh weather conditions.

(B) Iron, plastic sheeting, wood, mud and tin

(C) Dumps, collected along the road, hardware shops

(D) The negative impact includes: soil erosion because of the removal of vegetation to build informal houses, pollution: air pollution because of fires used to cook food, boil water and warmth, and land pollution: litter (accept other answers).

## Week 6

### Lesson 11

The learners need to look at chemicals used to waterproof textiles.

#### **ACTIVITY 14** Flammable textiles: Teacher demonstration lesson LB p. 151

Learning activities:

- You should demonstrate the properties of textiles in the lesson or group activity (flammability test and absorbency test ).
- Record data (Observation Sheet)
- Individual Activity: Written task

Assessment tools and methods:

- Corrections of observation task
- Observation sheet

**Additional resources needed:**

- Strips of different textured fabric
- Candle
- Braai tongs
- Matches or lighter
- Bowl of water
- Observation sheet (Appendix 3)

**ACTIVITY 15**     **Waterproofing chemicals: Teacher demonstration lesson LB p. 151**

The learners need to look at the burning characteristics of textiles.

Table of textiles:

Type of fabric	Reaction to flame	Odor
Cotton	Continues to burn and turns to ash	
Silk	Burns slowly, can self-extinguish, will smoulder for some time.	
Synthetic fabric	Usually plastic-based so will flame and burn quickly. Will melt, leaving a molten residue.	
Wool	Difficult to ignite, will often extinguish in the flame.	

## Week 6

### Lesson 12

The learner needs to write a design brief with specifications for a suitable textile that can be used to build an emergency shelter. They should plan this design using free hand sketches of emergency shelters. Note that the next lesson (Lesson 14) requires building an emergency shelter which will require getting materials in advance and an appropriate amount of time. The learners may need to begin this in Lesson 13.

#### Focus: Design Skills

**ACTIVITY 16**     **Revision LB p. 152**

Learning activities:

- Learners sketch design ideas
- Learners make an informed choice regarding design ideas
- Draw up a design specification sheet
- Plan building task (Lesson 13/14)

Assessment Methods and Tools:

- Informal Educator assessment; observation of completion of tasks

**Additional resources needed:**

- You should provide copies of the planning sheet (Appendix 4) and copies of the assessment rubric (Appendix 5).

Learners individually draw design ideas then working in their allocated groups in Lesson 9 Activity 12. The learners then choose the best idea, give reasons for their choice and draw up a design specific sheet for the model of the shelter they will build.

Learners need to list resources and equipment needed and allocate tasks to group members.

Hand out assessment rubrics to be used in the assessment of the task (Appendix 5). Discuss the criteria so that learners are aware of what is expected of them and how marks will be allocated.

The learners need to complete their homework task by filling in a planning sheet (Appendix 4).

## Week 7

### Lesson 13 and 14: The learners need to make a model of an emergency shelter

**ACTIVITY 17** Making skills LB p. 153

Learning activities:

Learners build a model of a refugee shelter in the two hours allocated for them.

Assessment tools and methods:

- PAT: Formal Assessment Task to be done under educator supervision
- Observation
- Assessment rubric

Additional resources needed include:

- Learners need to provide their own resources to complete the task.
- Assessment rubric (Appendix 5)

All learners should have a copy of the assessment rubric (Appendix 5).

Learners will work in groups to build a model of an emergency shelter, keeping the specifications and criteria given in the assessment rubric in mind. All members of the group need to be actively engaged in the task. This task is to be completed in the allocated time of two hours.

The skills focus of this particular PAT is to **design** and **make**.

Use Appendix 5 to assess the task.

## **Section E: Photocopiable resources**



This part of your Teacher's Guide is for storing all photocopiable templates, worksheets, and resources that are provided and that you may come across in your planning and research.

**Record sheets and Assessment templates and worksheets**

**E3**





## Generic analytic rubric

### An example of a generic analytical rubric to assess design capability in a PAT

Levels of competence					
		Competent	Developing but not yet mastering	Progressing	
	5	4	3	2	1
<b>Generate and develop design ideas</b>	Uses drawings reflectively to generate new ideas	Progression of ideas across of within drawings	Design ideas are generated but not developed	Simple sketch showing object to be made	Drawing a picture not designing a product
<b>Explore the possibilities of the problem/need</b>	Combining novel solutions to produce innovative design	Using drawings to develop novel design solution(s)	Recording possible creative solution(s) to the task	Stereotypical response, showing little creative thought	Design possibilities are not addressed in the drawing
<b>Address the constraints of the problem/need</b>	Task constraints treated as part of iterative process	Task constraints considered as the design proceeds	Records way to address task and/or client needs and wants	Drawings show some understanding of task constraints	Minimal understanding of task/user needs
<b>Plan the look of the product</b>	Ideas about finishing develop within overall design	Ideas about finishing are added to design whilst drawing	Overall decoration scheme considered	Little consideration of final appearance of product	Appearance of product is not considered
<b>Communicate design ideas</b>	Clear enough for somebody else to make the product	Conveys sense of the object to be made, e.g. working diagram	Conveys some sense of the object to be made, e.g. indicates materials	Simple unlabelled sketch(es); relying on shared meanings	Use of narrative or other drawing genre
<b>Plan construction</b>	Constructional issues considered en route to final design	Drawing demonstrates consideration of construction	Drawing indicates some consideration of construction	Minimal consideration of construction while drawing	Not planning to make the object drawn
<b>Evaluate while drawing</b>	Changes made as a result of considering design drawings	Decisions made about products while drawing	Considered and rejected a range of ideas	Minimal evaluation at drawing phase	Yet to define the design task
<b>Provide a basis for making</b>	Using drawings as a resource during making	Clear development path through drawing into making	Object is one of the ideas drawn	Product relates to ideas recorded in the drawing	Making an object is seen as separate new activity
Comments to improve the learner's performance in design capability:					

# Worksheet for oblique drawing

Complete the following drawing of a bracket in oblique using the measurements given.

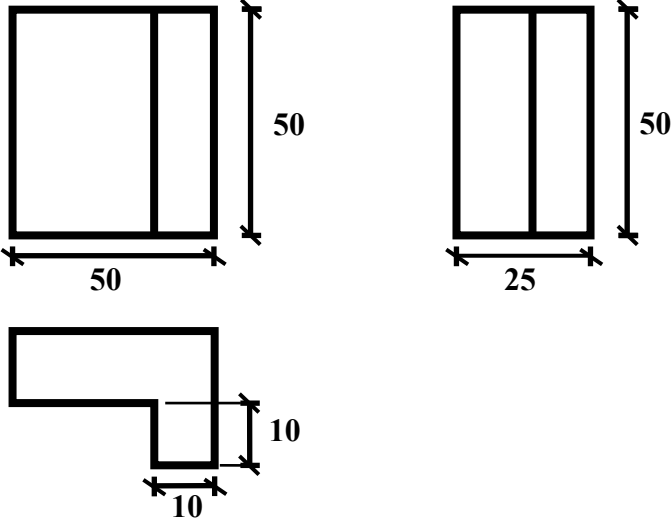

Grid

A large grid area for drawing the oblique drawing of the bracket.

## Worksheet for perspective drawing

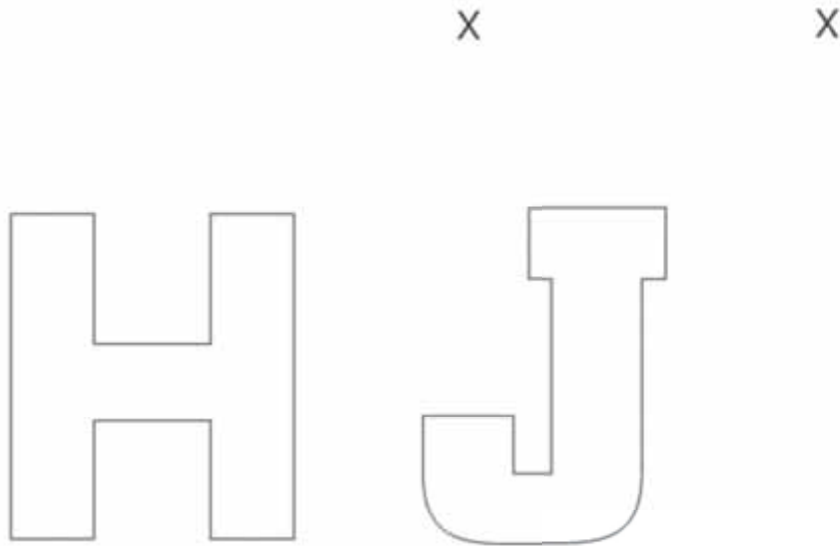

### One Point Perspective Worksheet

Using one perspective, parallel lines converge to one point somewhere in the distance. This point is called the vanishing point (VP). This gives objects an impression of depth.

When drawing using one point perspective, all objects vanish to one common point somewhere on the horizon.

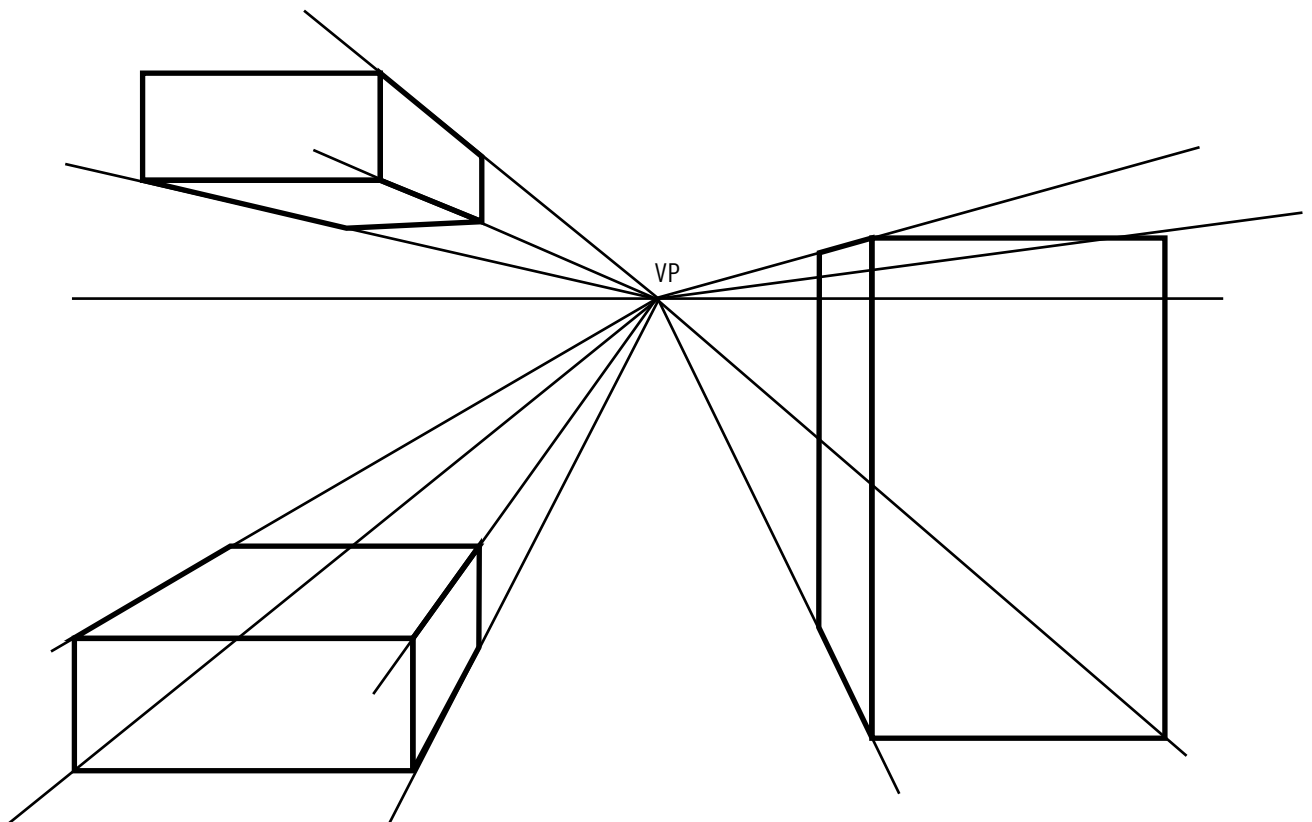

## Worksheet on one point perspective

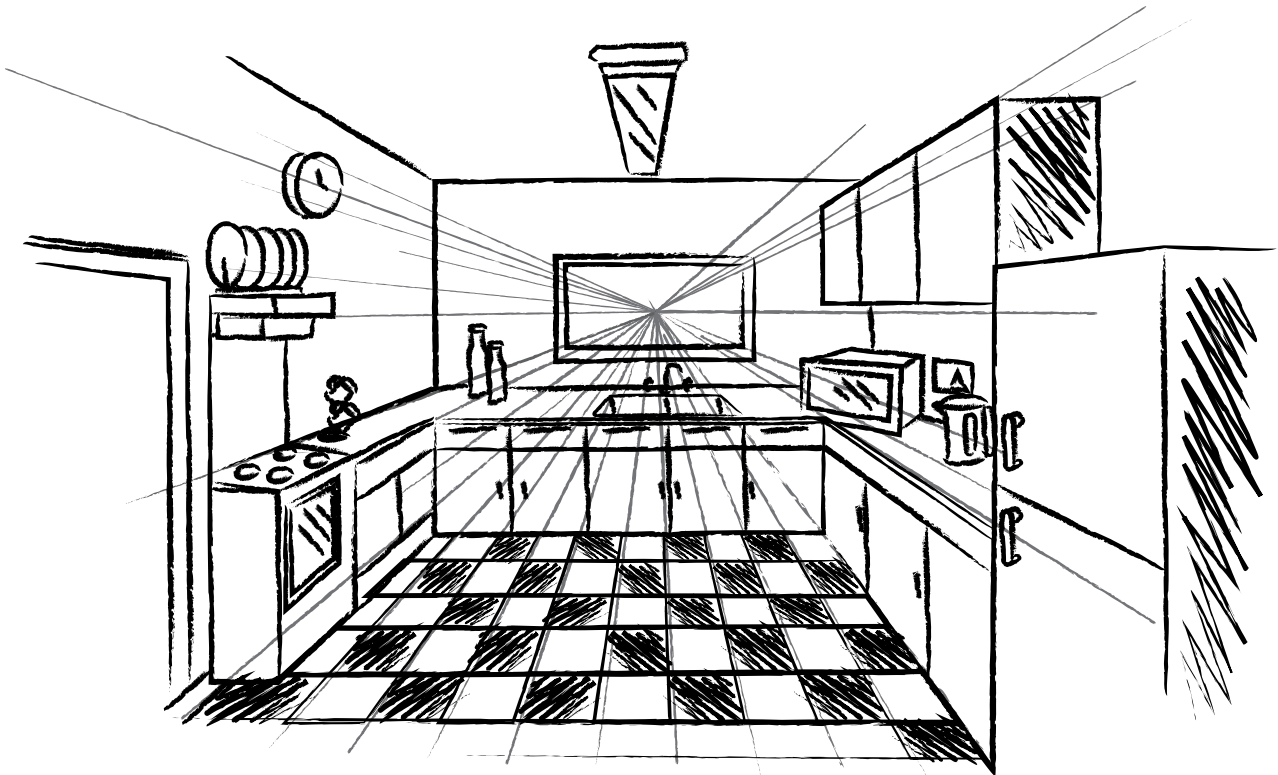

Although it is possible to sketch products in one point perspective, the perspective is too aggressive on the eye, making products look bigger than they actually are.

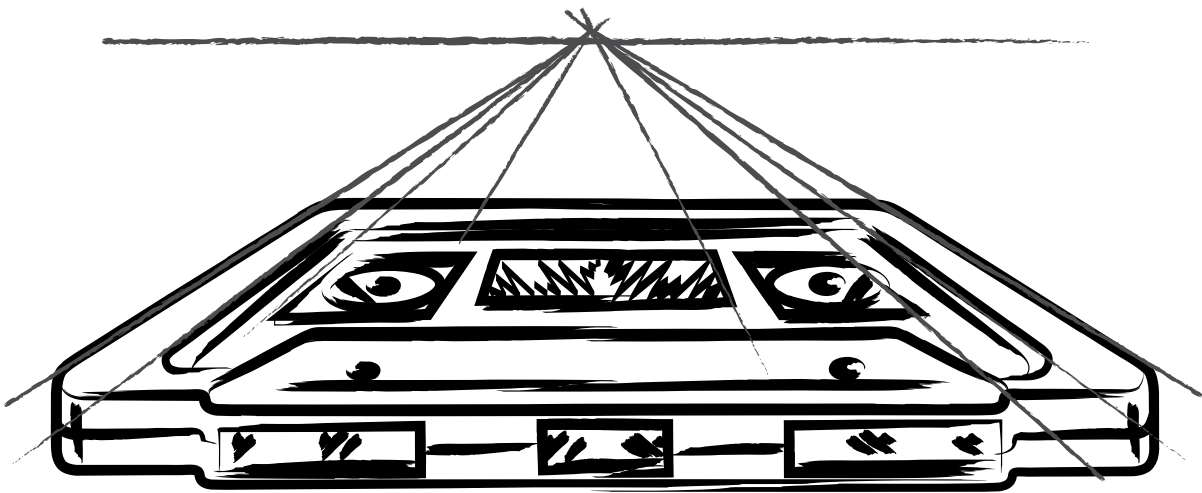

## Worksheet on levers

### Purpose of levers:

Levers work with the strength that the operator applies to the job in order to do more work.

### Examples of levers:

Seesaw, balance scale, scissor lifts, bottle opener, fishing pole.

### How to use levers:

#### Load

Levers have three parts: fulcrum, effort, and load

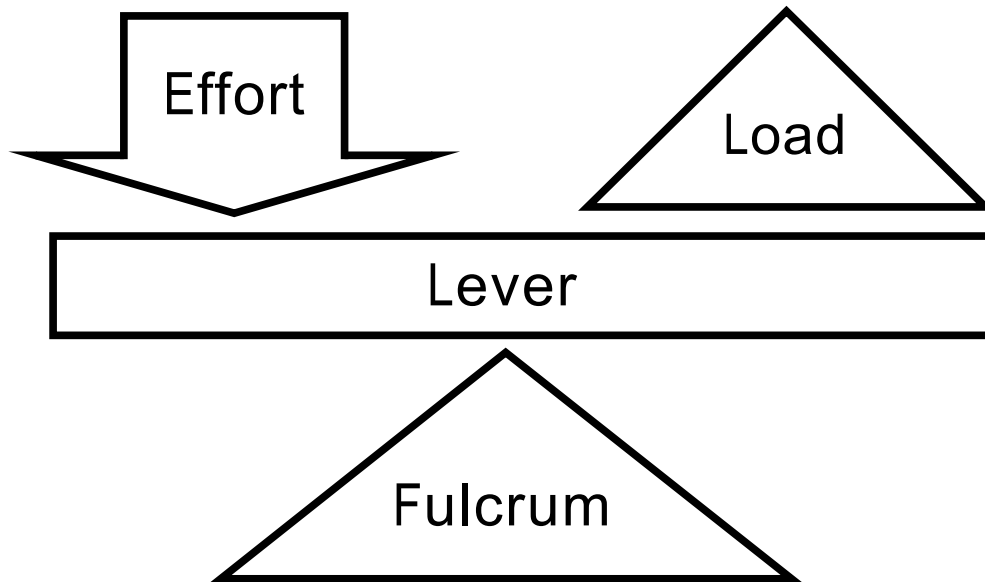

#### Load:

- The fulcrum is the place where the lever rocks back and forth, or the pivot point.
- The effort is the amount of force the operator has to apply.
- The load is the object to be lifted or lowered.
- When the fulcrum is in the middle of the lever, the amount of effort the operator pushes down equals exactly the amount of the load lifted on the other end.
- When the fulcrum is closer to the load, the operator does not have to push down as hard to lift the same weight, the difference is the operator will have to push down a longer distance.

There are three classes of levers.

- In the first-class lever the fulcrum is in the middle with the effort on the left and the load on the right.
- In the second-class lever the load is in the middle with the fulcrum on the left and the effort on the right.
- In the third-class lever the effort is in the middle with the fulcrum on the left and the load on the right.

## Worksheet on levers (continued)

Identify the class of lever illustrated in each example. Mark the fulcrum with a dot.



1. Which class of lever is the crocodile's jaw?  
\_\_\_\_\_



2. When he pulls up the rod with his right hand, what type of lever is he using?  
\_\_\_\_\_



3. Which lever is used to flip the egg?  
\_\_\_\_\_



4. Which lever is used to make a hole?  
\_\_\_\_\_



5. Which lever is used in rotating the broom?  
\_\_\_\_\_



6. Which lever is the flagpole they are raising?  
\_\_\_\_\_



7. Which lever is not being used properly?  
\_\_\_\_\_



8. Which type of lever are the wire cutters?  
\_\_\_\_\_



9. Which class of lever is the wrench?  
\_\_\_\_\_



10. Examine the mechanism that moves the drum stick. What type of lever is it?  
\_\_\_\_\_



11. A seesaw is an example of which class of lever?  
\_\_\_\_\_



12. A wheelbarrow is an example of which type of lever?  
\_\_\_\_\_

# Self Assessment Worksheet

Complete this worksheet to test your knowledge of structures (at the end of Unit 4.3)

**A. Look at each of the pictures. Name the force at work. Draw in an arrow showing the direction of the force:**

1. A hand squeezing a ball
2. Books on a shelf
3. Opening a jar
4. A chain breaking as it carries a weight which is too heavy
5. A car crashing into a wall

a.



b.



c.



d.



e.



**B. Label these different forces**

DESCRIPTION	FORCE
This force pushes parts of a structure together	
This force causes twisting	
This force causes the member to sag or bend	
This force causes the structure to break or split	
This force tries to pull the parts or members away from each other	

**C. Give your own example of the five forces at work.**

**D. Draw a picture to illustrate the following parts of a structure.** Illustrate only three of the following:

- A strut
- A buttress
- A beam
- A column
- A guy

**E. Think of questions to ask before designing and building a structure. Ask at least five questions.**



## Answers to Self Assessment Worksheet

- A.**
1. Compression
  2. Compression
  3. Torsion
  4. Shearing
  5. Compression

**B.**

DESCRIPTION	FORCE
This force pushes parts of a structure together	compression
This force causes twisting	torsion
This force causes the member to sag or bend	bending
This force causes the structure to break or split	shearing
This force tries to pull the parts or members away from each other	tension

**C.** Answers will vary

**D.** Students choose three parts of a structure to illustrate

**E.** Some of their questions may include the following:

- What factors in the environment can affect the structure?
- What is the mass and size of what the structure needs to support?
- What is the mass of the structure itself?
- How much will it cost to build the structure?
- Is the structure safe?
- What resources are available to build the structure?
- How will the presence of the structure affect the environment and the community?

For each of these objects, decide whether or not the object needs to be strong in tension, compression or torsion.

## Record Sheets and Checklists for Electrical Systems and Control

Here is an example of a table that the groups can use to keep record of their recycling scheme:

Types of materials recycled	Number of bins collected	Date scrap materials were sold	Amount of money used for transport	Amount of money made
Paper and magazines				
Glass bottles				
Scrap metal				
Plastic bottles				
Cardboard				
Aluminium cans				

Here is a quick revision exercise that the learners can write in their Technology book and then complete a peer assessment:

Which metals were attracted to the magnet?
Name some of the materials that you can re-cycle in your area.
Why do you think you should separate the waste materials?
Did you manage to organise someone to whom you can sell your waste materials?
Did you set up your recycling area neatly and with the correct labels?

Peer assessment checklist:

	Yes	No	Comment
Were they able to co-operate with the other members of the group?			
Did they manage to sort out which metals were attracted to a magnet?			
Did they select suitable material or materials for recycling?			
Are they organising their recycling bins?			
Have they encouraged other learners from the school to collect materials for them?			
Are they keeping a record of the materials they have collected?			
Are they keeping a record of the money they are making?			

Copy this table into your books and then record your findings:

Materials	Attracted to magnet	Not attracted to magnet	Can you give a reason why?

Self-assessment:

	Yes	No	Comment
Were you able to answer the questions on your own?			
Do you have a good understanding of magnetism?			
Did you manage the experiments in your group?			
Did you manage to tabulate the materials that were attracted and not attracted to a magnet?			
Did you co-operate with your group?			

## Record Sheets and Checklists for Emergency Situations

Emergency situations that lead to refugee situations

Natural Disaster	Refugee Situation	Reasons

Self-assessment rubric:







Reflection question	Yes	No	Comment
I knew the answers to all the questions.			
I have a good understanding of refugees and the types of problems they face.			
My group worked effectively on the making task.			
My group was able to choose a practical item to prepare.			
I think that my marks for tasks completed so far are good.			

Materials and building materials used by indigenous people in South Africa:

Indigenous people	Province in which people live	Shape of home	Materials used	Building technique used	Impact on the environment
Zulus	KwaZulu-Natal	Dome-shaped	<ul style="list-style-type: none"> <li>• Wood</li> <li>• Dry grass</li> <li>• Mud</li> </ul>	Weaving	<ul style="list-style-type: none"> <li>• Trees and grass are cut to provide the resources needed</li> <li>• Materials used can easily catch alight and cause widespread damage</li> </ul>

# Formal Assessment Task: Mid-year exams

1. Look at the following pictures and identify the kind of structure of each.

<p>a) skeleton</p> 	<p>b) cool drink can</p> 	<p>c) mine headgear</p> 
<p>d) windows (set)</p> 	<p>e) chair</p> 	<p>f) column</p> 

(6)

2. Explain carefully the differences between the kinds of structures in Question 1.

(4)

3. Fill in the following table:

STRUCTURE	MAN-MADE	NATURAL	FUNCTION
Tree			
Bridge			
Honeycomb			
Juice carton			
Egg-box			

(15)

4. Choose answers from the box



ladder/building	skeleton
frame	shell
found/situated	snail
	seen

- a) A ..... structure is made up of different parts which are joined together.
- b) Altogether the different parts make up the .....
- c) A ..... is an example of a frame structure.
- d) The frame structure cannot always be ..... as it is often ..... inside.
- e) An example of this is a ..... It supports the other parts of the body like the heart, lungs, brain and the stomach.

- f) ..... structures are not made up of different parts.
- g) They do not have a .....
- h) The ..... structure provides its own support.
- i) The ..... is an example of a shell structure.

(9)

5. Look at the pictures and label the forces at work in each picture.

<p>a) Putty being stretched</p> 	<p>b) Elephant pulling a load</p> 
<p>c) Handshake</p> 	<p>d) Opening a jar</p> 
<p>e) Two people standing on a beam which is bending</p> 	

(5)

6. Match the force with its description. Fill in the correct number next to the letter.

FORCES	DESCRIPTION
A. Compression	1. Directions. It is a cutting force.
B. Torsion	2. This force squashes an object.
C. Tension	3. One surface is squashed while the other is pulled.
D. Bending	4. Here the structure is twisted.
E. Shearing	5. This happens when the structure is stretched.

- A. .... B. .... C. ....  
 D. .... E. ....

(5)

7. List the three basic functions of a structure. (3)

8. Look at the pictures and label the structural parts shown by the arrows. (7)

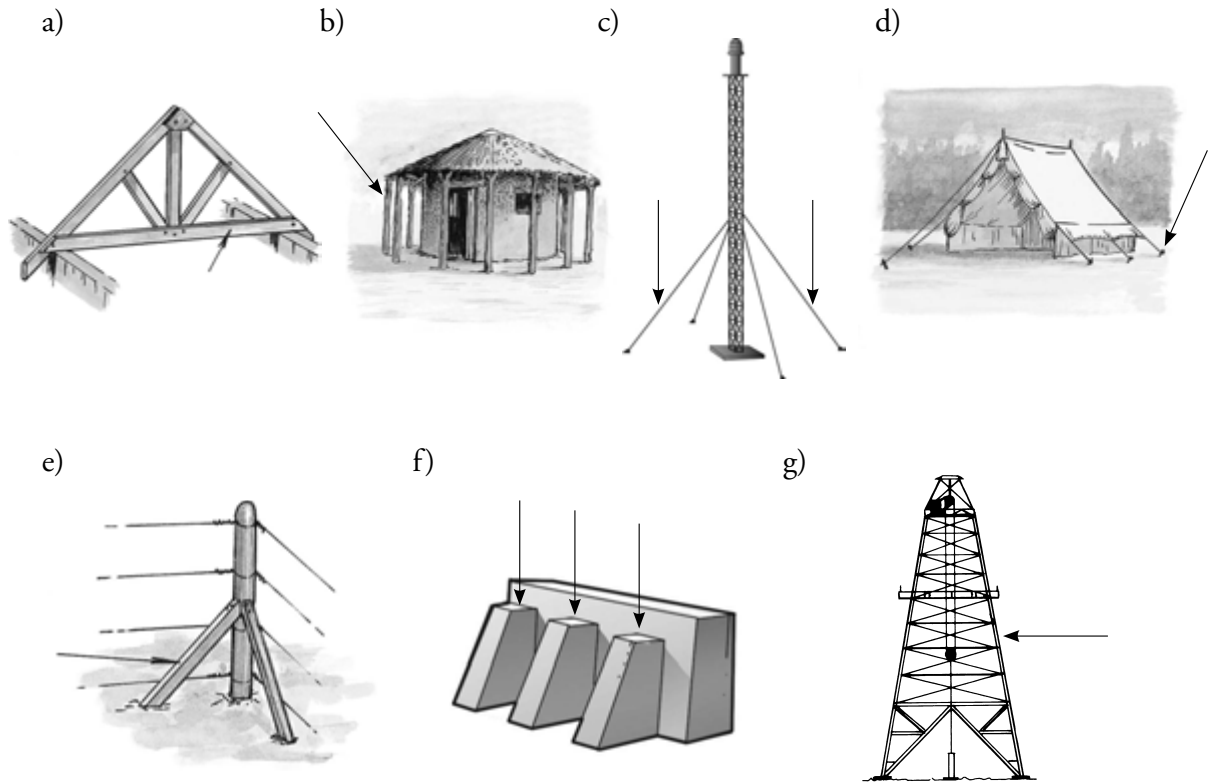

9. Look at the pictures below and decide what makes each of the following stable or unstable. (5)

- a) Water tower
- b) A candlestick with a broad base
- c) A sports car
- d) A man on a heavily overloaded bicycle
- e) A tower supported by buttresses

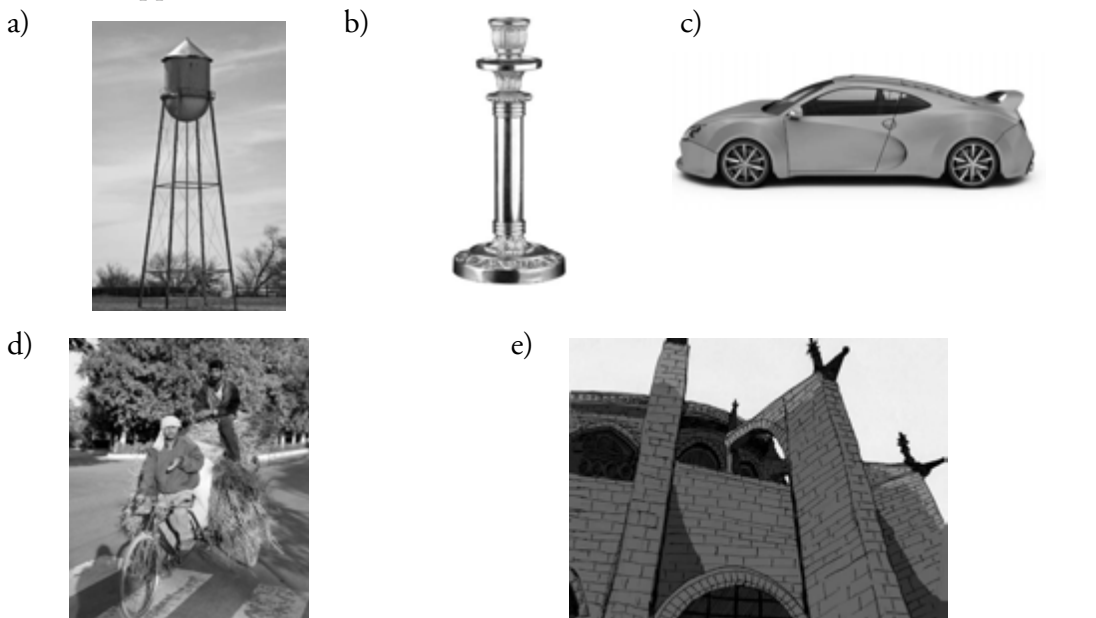

10. Look at these two pictures. In each a material is being strengthened.

- a) How is it being strengthened?
- b) What is the process called?

(4)

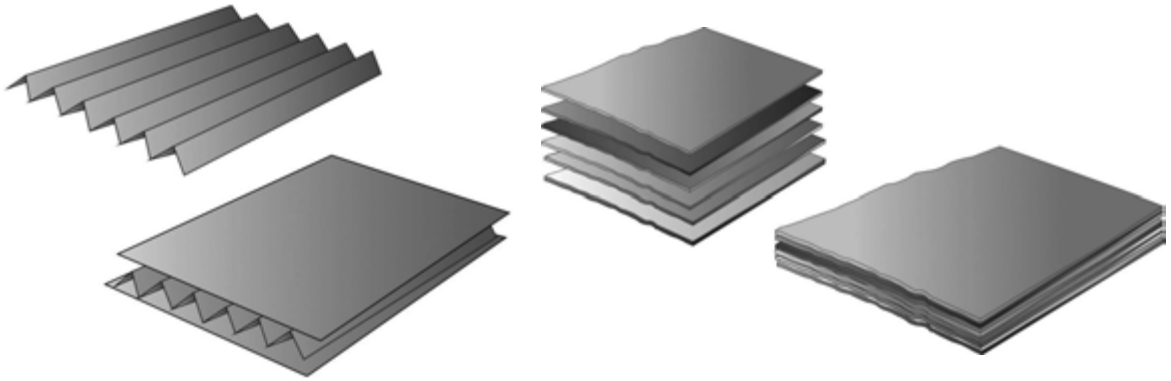

11. a) How would you strengthen this farm gate?



- b) What is this process called?

(2)



12. a) Look at the picture of visual pollution and describe what you understand by the term 'visual pollution'.



- b) Who is responsible for this?  
c) What can you do to prevent it from happening? (6)
13. 

Using the picture above, explain vanishing point and label it on the picture. (2)

14. a) Write a design brief for the following
- A bag for marbles
  - Or
  - A stationery holder for a desk
- b) Write at least five specifications for your design brief. (5)

15. Name six safety rules which might be broken in a Technology classroom. (6)
16. South Africa was awarded the Soccer World Cup for 2010. The main grandstand had to be upgraded specifically to cater for elderly and disabled spectators. The design needed a ramp for wheelchairs, and suitable stairs for elderly people to be able to use in comfort.

Here is a design submitted by a hopeful contractor. The design is poor and will be rejected.

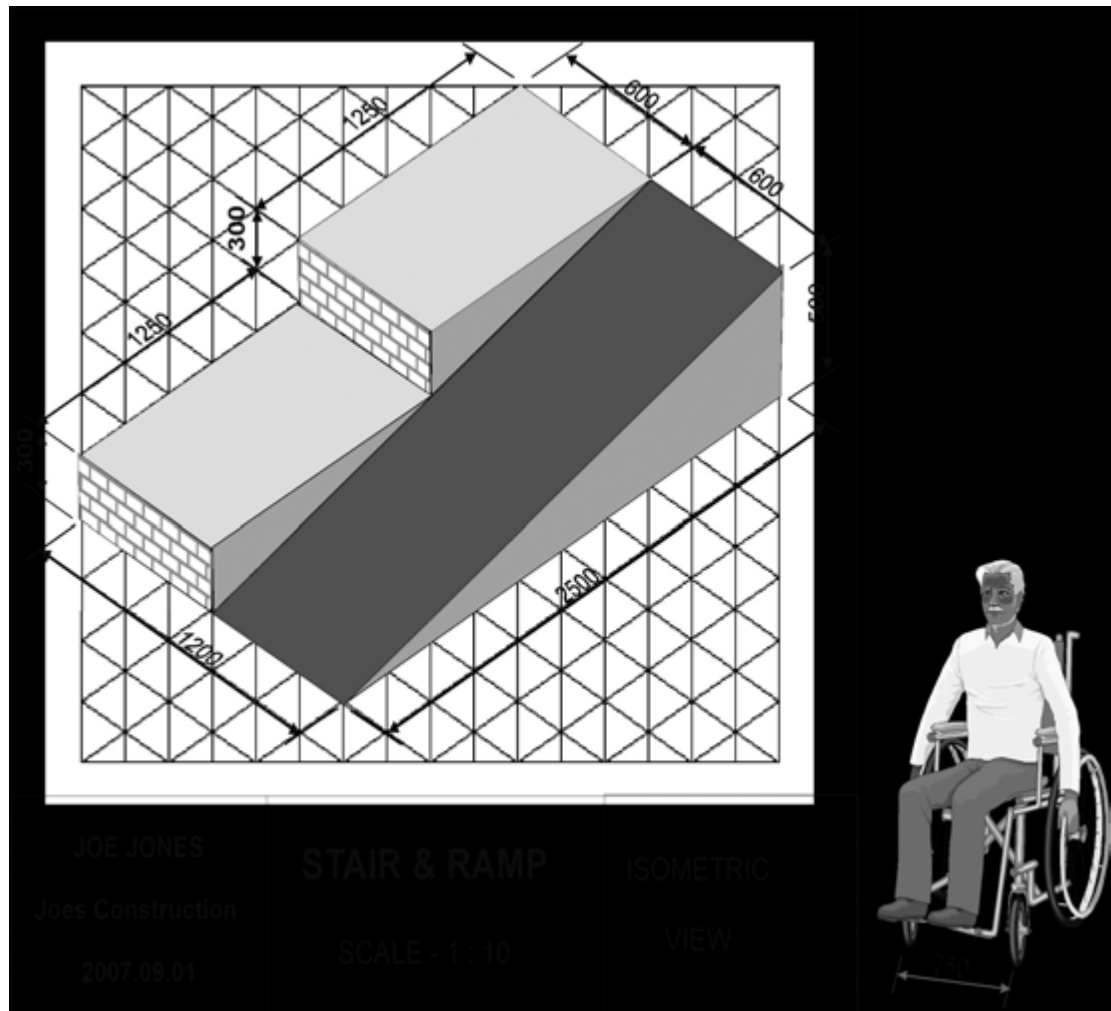

- a) List four problems with the design and propose solutions for each problem. [4]

$\left. \begin{matrix} 88 \\ 2 \end{matrix} \right\} = 44$  marks or  $\left. \begin{matrix} 44 \\ 4 \end{matrix} \right\} = 11$

## Formal Assessment Task: Mid-year exams memorandum

1. a) Frame  
 b) Shell  
 c) Shell  
 d) Frame  
 e) Frame  
 f) Solid (6)

2. A frame structure is composed of different parts joined together. These parts make up the frame. Sometimes something is supported from inside, for example a skeleton supports the body and is a frame structure. Sometimes the framework of the structure is hidden as it provides protection from within.

A shell structure is not composed of different parts. Rather it is one whole piece. It does not have a frame as a support as the shell acts as the support. It is usually lighter in weight than a frame structure. The strength comes from the shell itself. The body of a car is a shell structure.

These solid structures are not made of different parts but are 'one form' structures, such as a column. (4)

3.

STRUCTURE	MAN-MADE	NATURAL	FUNCTION
Tree		yes	Support, protect
Bridge	yes		Span, support
Honeycomb		yes	Support, protect
Juice carton	yes		Contain, protect
Egg box	yes		Contain, protect

(15)

4. a) Frame  
 b) Frame  
 c) Ladder  
 d) Found/Situated  
 e) Skeleton  
 f) Shell  
 g) Frame  
 h) Shell  
 i) Snail (9)

- 5 a) Tension  
 b) Tension  
 c) Compression  
 d) Torsion  
 e) Compression and tension (5)

6. A 2; B 4; C 5; D 3; E 1 (5)
7. Hold or support  
Span or reach  
Protect, close or contain (3)
8. a) Beam  
b) Columns  
c) Guys/ties  
d) Guys/ties  
e) Struts  
f) Buttress  
g) Triangulation (7)
- 9 a) Broad base  
b) Broad base  
c) Low on the ground  
d) Top too heavy  
e) Buttress supporting wall (5)
10. a) By putting a folded concertina piece of paper between two sheets of paper and by gluing several sheets of the material together.  
b) Corrugation and lamination (4)
- 11 a) A cross brace  
b) Triangulation (2)
- 12 a) Pollution of the skyline by poor architecture, adverts and smog (3)  
b) People (1)  
c) Municipal by-laws, complaints to councillors, city planner (2)
13. Where the two sides of the railway line appear to meet in the distance and you cannot see any further. (2)
14. **Bag of marbles.** See page E23: Example of a design brief checklist.  
**A stationery holder for a desk.** See page E24: Design brief checklist for a stationery holder. (5)
- (Both the information that goes into the design brief and the specifications are contained in these documents.)

15. Learners may choose any six of these safety rules (6)

Tools:

- Never leave tools near the edge of the bench top, rather put them away or far back on the bench.
- Walk, do not run, with tools.
- Tools should be kept sharp.
- Never use a file without a handle.
- Hammer heads should be firmly wedged onto their handles.
- Only use when in the technology room.
- When carrying tools carry them with their cutting edge or point facing downwards.
- Never put nails or sharp objects into your mouth.
- Report any faults in equipment to your teacher immediately.
- Wear safety goggles when working with equipment.

Clothing:

- Sleeves should be buttoned or rolled up out of the way.
- Ties should be tucked into shirts.
- Shoe laces should be tied.
- Long hair should be tied up.

Electricity:

- Never use faulty, or frayed cords, or equipment with loose connections.
- Always switch off the current when not in use.
- Never undertake repairs, ask an expert.

General:

- Put all tools back where they are stored when not in use.
- Pick up any scraps or off-cuts of materials.
- Clean up oil or paint spills immediately.
- If accidents occur, seek first aid immediately.
- Always report all accidents even if small.
- Wash hands thoroughly after using things like oil, turps, thinners and varnish.
- Enter the room sensibly.
- Do not interfere with the work of other learners.
- Always get your teacher's permission before using equipment.

16. (4)

Error identified (any four needed)	Mark	Solution proposed (any four needed)	Mark
Ramp too narrow	1	Widen ramp to at least 800mm	1
Ramp too steep (5:1 gradient)	1	Lengthen structure to at least 4m	1
Stair riser too high	1	Add additional stair	1
No handrail to add safety for users	1	Add handrail	1
No barrier to prevent wheelchair running off the ramp	Or 1	Add low barrier such as a line of bricks OR Add handrail at wheel-height (better idea - learners can score a bonus mark for this)	Or 1

$$\left(\frac{88}{2} = 44 \text{ marks or } \frac{44}{4} = 11\right)$$

## Example of a design brief checklist

DESIGN BRIEF	4	3	2	1	COMMENTS
<b>Problem is stated in simple sentences (4 marks)</b> A large bag in which to carry marbles as the learner needs to be able to take them to school to play games at break.					
<b>Solution is described simply (4 marks)</b> Make a bag from scrap materials or strips of plastic, with a draw string to close the opening.					
<b>The function of the product is described (4 marks)</b> Sturdy bag to hold the marbles securely.					
<b>The user is described (4 marks)</b> Boys and girls from Grade 1–7					
<b>The context is described (4 marks)</b> A hard wearing bag to hold marbles in a schoolbag					
SPECIFICATIONS					
<b>Specifications with regard to size (4 marks)</b> 15 cm by 12 cm					
<b>Specifications with regard to features (4 marks)</b> Must have a drawstring to close the opening securely					
<b>Specifications with regard to attractiveness of design and use (4 marks)</b> Bright colours, durable material					
<b>Specifications with regard to price (4 marks)</b> Under R10					
<b>Specifications with regard to the target market and durability (4 marks)</b> Will handle constant use, so strong Grade 1–7 boys and girls					
<b>Specifications with regard to appearance (4 marks)</b> Bright and colourful					

## Design brief checklist for a stationery holder

Stationery holder

DESIGN BRIEF	4	3	2	1	COMMENTS
<p><b>Problem is stated in simple sentences (4 marks)</b> A container is needed in which to keep pens, pencils, erasers, a ruler, pencil crayons and kokis which will stand on the desk.</p>					
<p><b>Solution is described simply (4 marks)</b> Make a container with various compartments in which to store the items. It must stand on the desk.</p>					
<p><b>The context is described (4 marks)</b> It must be able to stand on a desk without taking up too much space and be stable, and provide storage.</p>					
<p><b>The function of the product is described (4 marks)</b> A sturdy container to keep stationery safely and neatly and readily available.</p>					
<p><b>The user is described (4 marks)</b> Boys and girls from Grade 1–7</p>					
<p><b>Specifications with regard to how the bag should be opened and closed (4 marks)</b> It must have an opening at the top with a drawstring to pull it closed.</p>					
<p><b>Specifications with regard to size (4 marks)</b> It must be large enough to hold the stationery but not occupy too much space on the desk.</p>					
<p><b>Specifications with regard to price (4 marks)</b> Under R10</p>					
<p><b>Specifications with regard to the target market and durability (4 marks)</b> Will it handle constant use?</p>					
<p><b>Specifications with regard to appearance (4 marks)</b> Bright and colourful</p>					

## Rubrics and checklists for cell phone tower

<b>The LEARNER:</b>	<b>4: HIGHLY EFFECTIVE (MARKS 4/5)</b>	<b>3: MOST AREAS ARE EFFECTIVE (MARKS 3)</b>	<b>2: SOME AREAS ARE EFFECTIVE (MARKS 2)</b>	<b>NOT EFFECTIVE (MARKS 1)</b>	<b>COMMENTS</b>
A. INVESTIGATES Understands the problem context.	A. INVESTIGATES There is evidence of an excellent understanding of important ideas	A. A good understanding of important ideas	A. Some relevant ideas were considered	A. Ideas were not appropriate	
Produced flow diagram/sequenced notes on making the tower.	A. Understands problem well	A. Good understanding	A. Partial understanding	A. No understanding	
B. COMMUNICATES Is able to manufacture a product according to the design brief.	A. Excellent sequence of steps	A. Good sequence of steps	A. Partial sequence	A. No sequence	
Communicates ideas clearly in the presentation.	B. COMMUNICATE Product followed design brief and specifications	B. Good interpretation of design brief and specifications	B. Incomplete interpretation of design brief and specifications	B. Product differed widely from design brief and specifications	
Explains his/her role clearly in the presentation.	B. Ideas clearly and accurately presented	B. Good presentation of ideas	B. Ideas were muddled and presentation was average	B. Presentation was poor. Ideas not clear	
Has drawn and developed working drawings: 1 drawing using oblique perspective 1 drawing using 1VP perspective.	B. Role clearly defined	B. Good definition of role	B. Vague definition of role	B. No definition of role	
Has contributed to the decision making and discussions in the group, with regard to the choice of working drawing for the final plan and evaluation of group members' drawings.	B. Excellent working drawings	B. Good working drawings	B. Some aspects present in drawings	B. Poor working drawings	
Use of portfolio to communicate technological processes.	B. Excellent contribution to discussions	B. Good contribution to discussions	B. Contribution little	B. No contribution	



<b>The LEARNER:</b>	<b>4: HIGHLY EFFECTIVE (MARKS 4/5)</b>	<b>3: MOST AREAS ARE EFFECTIVE (MARKS 3)</b>	<b>2: SOME AREAS ARE EFFECTIVE (MARKS 2)</b>	<b>NOT EFFECTIVE (MARKS 1)</b>	<b>COMMENTS</b>
C. UNDERSTANDING OF KNOWLEDGE AND CONCEPTS Is able to use and apply research findings on strengthening structures, rigidity and stability.	C. KNOWLEDGE In depth knowledge of structural concepts	C. Good knowledge of structural concepts	C. Understands structural concepts with assistance	C. No understanding	
D. PROBLEM IDENTIFIED	D. Generation of ideas Able to think up several relevant ideas	D. Able to generate at least 2 ideas	D. Needs assistance to follow through ideas	D. Unable to follow through with ideas	
Follows through on ideas that have been developed in a logical way.	D. APPLICATION OF TECHNICAL PROCESS Applies technical process correctly	D. Good application	D. Needs assistance to apply technological process	D. Technological process incorrectly applied	
Is able to solve the problem by applying the technological processes correctly.	C. KNOWLEDGE In depth knowledge of structural concepts	C. Good knowledge of structural concepts	C. Understands structural concepts with assistance	C. No understanding	
E. DESIGN Has contributed towards the design and execution of a poster for the group discussions in the group.	E. DESIGN, EXECUTION OF POSTER Excellent visual appeal, bold lettering, excellent use of colour, shading	E. Good visual appeal, fair size lettering, good use of colour, shading	E. Some visual appeal, lettering poor, some use of colour, shading	E. Little visual appeal, poor lettering, poor use of colour, shading	
A variety of creative options were explored.	E. Variety of very creative options	E. Good creative options	E. Some creativity	E. Little or no creativity	
F. MAKE Worked neatly and safely when using tools.	F. MAKE Used tools safely	F. Mostly safe usage	F. Some safety aspects considered	F. Ignored safety aspects	
Made a list of resources needed.					
Made a list of tools needed.	F. All resources listed	F. Most resources listed	F. Some resources listed	F. Few resources listed	

<b>The LEARNER:</b>	<b>4: HIGHLY EFFECTIVE (MARKS 4/5)</b>	<b>3: MOST AREAS ARE EFFECTIVE (MARKS 3)</b>	<b>2: SOME AREAS ARE EFFECTIVE (MARKS 2)</b>	<b>NOT EFFECTIVE (MARKS 1)</b>	<b>COMMENTS</b>
Is able to bear in mind all the specifications when making the product.	F. All tools listed	F. Most tools listed	F. Some tools listed	F. Few tools listed	
Model was well built and attractive.	F. All specifications followed	F. Most specifications followed	F. Some specifications followed	F. Few specifications followed	
Model blended in with environment as much as possible.	F. Good workmanship, attractive	F. Acceptable quality, quite attractive	F. Errors in workmanship, does not blend in	F. Product incomplete, no attempts to blend in	
<b>G. EVALUATE</b> Is able to evaluate own model, drawings and presentation.	<b>G. EVALUATE</b> Product and process evaluated, recommendations made	<b>G.</b> Good evaluation	<b>G.</b> Either product or process evaluated or both done ineffectively	<b>G.</b> Product and process lack evaluation	
Is able to evaluate other learners' models, drawings and presentations.	<b>G.</b> Peer product and process evaluated, recommendations made	<b>G.</b> Good peer evaluation	<b>G.</b> Either product or process evaluated or both done ineffectively	<b>G.</b> Peer product and process lack evaluation	
<b>H. PLANNING</b> Stuck to time constraints.	<b>H. PLANNING</b> Well within time constraints	<b>H.</b> Delivered on due date	<b>H.</b> Shortly after due date	<b>H.</b> Well after due date	
Participated in preparing joint strategy for presentation.	<b>H.</b> Excellent strategy planning	<b>H.</b> Good strategy planning	<b>H.</b> Some good ideas, but rather haphazard	<b>H.</b> No strategy planning	

<b>DESIGN BRIEF FOR CELL PHONE TOWER</b>	<b>4</b>	<b>3</b>	<b>2</b>	<b>1</b>	<b>COMMENT</b>
The problem is clearly stated.					
The language is simple.					
All essential information is provided with regard to use and purpose.					
<b>SPECIFICATIONS</b>					
Were there specifications with regard to size?					
Were there specifications with regard to features?					
Were there specifications with regard to attractiveness of design and how it should blend in with the environment?					

CODE	Level Descriptor: The team ...
7	Completed the scale model, the standard of workmanship is excellent and the model is built accurately to scale and according to plan. All members of the team did participate.
6	Completed the scale model, the standard of workmanship is good and the model is built to scale and according to plan. All members of the team did participate.
5	Completed the scale model, the standard of workmanship is good but the model is not built to scale and according to plan. All members of the team did participate.
4	Completed the scale model, the standard of workmanship is good, but some members of the team did not participate.
3	Completed the scale model, but the standard of workmanship is poor. All members of the team did participate.
2	Completed the scale model but the standard of workmanship is poor and sloppy, and some members of the team did not participate.
1	Failed to complete the building of the scale model.

## ASSESSMENT RUBRIC

### Teacher Assessment

#### MODE: Team

7	All team members spoke; the presentation content was very well planned and very well delivered, using various extra aids like posters or overhead transparencies or a computer.
6	All team members spoke; the presentation content was well planned, and well delivered.
5	One team member spoke; the presentation content was well planned, and well delivered.
4	All team members spoke; the presentation content was well planned, but badly delivered.
3	One team member spoke; the presentation content was well planned but badly delivered.
2	All team members spoke but the presentation was poorly planned and badly delivered.
1	One team member spoke, the presentation was poorly planned and badly delivered.

## RUBRIC

### Poster

#### Teacher Assessment

#### MODE: Team

CODE	Level Descriptor:
7	The drawing is accurate, is drawn correctly in perspective, shows textures, colours, and shadows, and has additional detail (like trees, vehicles, people) that creates realism.
6	The drawing is accurate, is drawn correctly in perspective, and shows textures and colours and shadows.
5	The drawing is accurate, is drawn correctly in perspective, but shows only two textures or colours or shadows, not all three.
4	The drawing is accurate, is drawn correctly in perspective, but shows only one texture or colour or shadow, but not all three.
3	The drawing is inaccurate, perspective is attempted but is incorrect, does not attempt textures, colours, or shadows.
2	The drawing is inaccurate, perspective is not attempted, and does not show textures, colours, or shadows.
1	Little or no attempt is made to draw a poster.

## Analytic rubric for project task

**LEARNING AREA: TECHNOLOGY**

**GRADE: 7**

**TOPIC/CONTENT/FOCUS: STRUCTURES**

**ACTIVITY: PROJECT TASK**

**Completed project will be assessed according to this rubric.**

Categories	Levels of effectiveness			
	Highly effective Mark value 5 or 4	Most areas are effective Mark value 3	Some areas are effective Mark value 2	Not effective Mark value 1
Communicate: Use of a Project Portfolio to communicate the technology processes X2 = 10	Portfolio is highly organised and well planned. Excellent presentation of the technological processes.	Portfolio is organised and easy to follow. A strong knowledge of the technology processes is shown.	Portfolio is poorly documented and lacks creativity. Some sections are incomplete or inaccurate.	Portfolio is incomplete, contains incorrect information and reflects little effort. Reflects little knowledge of the technology processes.
Investigates/ Research done X2 = 10	There is evidence of an excellent understanding of the important ideas.	A good understanding of the important ideas.	Some relevant ideas were considered.	Ideas were not appropriate.
Problem identified X1 = 5	Design brief and specifications are clear and correctly written.	The design brief and specifications are clear.	The design brief and specifications are correct but required assistance.	Unable to write a design brief or list specifications.
Design X3 = 15	A variety of creative options are explored with effective communication using appropriate techniques.	Options given lack originality but are well presented with appropriate communication techniques used.	Options given are lacking in detail with little attention to communication techniques.	Options lack creativity and no detail is communicated.
Make X3 = 15	Good workmanship is displayed. Due attention is given to finishing.	Product presented is of an acceptable quality.	Product has many mistakes. Quality of finish is unacceptable.	Product is incomplete.
Evaluate against brief and specifications X1 = 5	The product and the process are evaluated and recommendations made.	The product and the process are evaluated effectively.	Only the product or the process is evaluated or both have been done but are not effective.	Product and process is not evaluated.
Understanding of knowledge concepts X2 = 10	An in-depth knowledge of structural concepts is shown.	Understands aspects of structural concepts.	Understands structural concepts when assisted only.	Unable to understand structural concepts.
Comment:				
Teacher.....			Date.....	
Learner: .....			Parent: .....	

## Assessment tools

**NAME OF LEARNER:** \_\_\_\_\_

**GRADE 7** \_\_\_\_\_

**TITLE OF THE PROJECT:** \_\_\_\_\_

**DATE:** \_\_\_\_\_

**FORM OF ASSESSMENT: PROJECT:**

CRITERIA	LEVELS OF PERFORMANCE				
	Highly effective	Most areas are effective	Some areas are effective	Not effective	Score
	5, 4	3	2	1, 0	
Technological Process					
Identifies the problem/need or want	The problem/ need/want is exciting and has a wide scope for new solutions.	The problem/ need/want offers good opportunities for new solutions.	The problem/ need/want offers some new opportunities.	The problem/ need/want offers little opportunities for new solutions.	
Researching	The learner has thoroughly researched the topic and related aspects of it.	The learner has read up and researched the topic sufficiently.	The learner has superficially read up on the topic, and can only answer basic questions.	It appears as if the learner has read and understood literature on the topic.	
Designing	The designs are very innovative and original and are very user friendly.	The designs are innovative in many aspects and are easy to use.	There are aspects of innovative designs evident and the designs are possible to use.	The designs show little innovation and are difficult to use.	
Planning skills	The learner has planned the execution of the design with care.	The learner has done adequate planning before attempting the design.	The learner has done some basic planning.	The learner shows little evidence of adequate planning.	
Making skills	The learner has used a wide range of complex manual skills.	The learner has used a range of different skills including some complex skills.	The learner has used many different basic manual skills.	The learner has used only a few basic manual skills.	
Use of material	The learner has made excellent choices of materials.	The learner has made appropriate choices of material.	The learner has made some poor choices of material.	The material is inappropriate.	
Record of the process	The design process has been recorded clearly, creatively and in great detail.	A comprehensive record of the design process has been compiled.	A record of the basic steps of the design only, has been compiled.	The record of the design process is sketchy and lacks clarity.	

Critical analyses and success of the design	The learner has already implemented improvements in a highly successful design.	The learner has good ideas for the improvement of a design which is basically successful.	The learner is aware of weaknesses but unable to suggest improvements in a design that shows limited success.	The learner is unable to pinpoint weaknesses in the design which does not really achieve what it was supposed to.	
Neatness and presentation	Exceptionally neat work that is presented in an innovative and eye catching manner.	Good effort to produce work that is neat and visually pleasing.	Some effort has been made to present work neatly but is visually not inspiring.	Very untidy. Project makes a negative impact and points to confusion.	
Confidence and enthusiasm	Learner is very confident and very enthusiastic about the project.	Learner seems confident and enthusiastic about the project.	Learner is not sure of topic and/or not enthusiastic.	Learner lacks confidence and/or enthusiasm.	
Product: Structures					
Specifications: The product must: Have a ramp that can move the cars from one level to the next Have at least three levels including the ground level Be able to carry 16 toy cars Fit in with the environment Must be accessible to all people	All the specifications have been met. Show a high level of knowledge and skills Product is completed. Product is fully functional. Product is safe to use and attractive.	Most of the specifications have been met Show a good level of knowledge and skills Product is greatly completed Product is complete but not functional Product is attractive and works well.	Some of the specifications have been met. Show a fair level of knowledge and skills. Product is partially completed. Product is not functional. Product is attractive but may have some safety problems.	Very little of the specifications have been met. Show very little knowledge and skills. Product is not completed. Product is not completed or functional. Product is not attractive.	X 2

Constraints The height must be at least 30 cm The parking garage must be under 30 cm in length and 30 cm in width, but longer than 15 cm and wider than 15cm. The budget for the parking garage is R75-00	All the constraint were taken into consideration Product is within the budget Completed within the time allocated.	Most of the constraints were taken into consideration. Product is close to the budget. Completed close to the time allocated.	Some of the constraints were taken into consideration. Product is not within the budget. Not completed within the time allocated.	Very little of the constraints were taken into consideration. Product is far outside the budget. Not completed at all.	X 2
Impact of technology					
Impact of technological developments on the quality of people's lives and the environment	Shows accurate evidence of having considered all the relevant factors that impact on people's lives and the environment at a complex level.	Shows accurate evidence of having considered all the relevant factors that impact on people's lives and the environment at an appropriate level.	Shows some evidence of having considered all the relevant factors that impact on people's lives and the environment at an appropriate level.	Shows little evidence of having considered all the relevant factors that impact on people's lives and the environment at a lower level than the appropriate level.	X 2
TOTAL / 80					
COMMENTS:					
SIGNATURE: _____ DATE: _____					

Score learners according to the following rubric:

Levels	Percentages (%)	Description
7	80 – 100	Outstanding achievement
6	70 – 79	Meritorious achievement
5	60 – 69	Substantial achievement
4	50 – 59	Adequate achievement
3	40 – 49	Moderate achievement
2	30 – 39	Elementary achievement
1	1 – 29	Not achieved

## Assessment scale for evaluation

Key elements, traits to be evaluated		LEVEL 7	LEVEL 6	LEVEL 5	LEVEL 4	LEVEL 3	LEVEL 2	LEVEL 1
		100 - 80%	79 - 70%	69 - 60%	59 - 50%	49 - 40%	39 - 30%	29 - 0%
		<b>Outstanding achievement</b>	<b>Meritorious achievement</b>	<b>Substantial achievement</b>	<b>Adequate achievement</b>	<b>Moderate achievement</b>	<b>Elementary achievement</b>	<b>Not achieved</b>
Assessment standards planned for in the assessment task are all <b>accurately</b> reflected at a <b>complex</b> level	Assessment standards planned for in the assessment task are all <b>accurately</b> met at an <b>advanced</b> level	Assessment standards planned for in the assessment task are <b>All accurately</b> met at the <b>appropriate</b> grade level	Assessment standards planned for in the assessment task are <b>mostly</b> met at the <b>appropriate</b> grade level	Assessment standards planned for in the assessment task are <b>partially</b> met at the <b>appropriate</b> grade level	Assessment standards planned for in the assessment task are met at a level <b>lower than the appropriate grade</b> level	Assessment standards planned for in the assessment task are <b>not correct</b> or the task is <b>incomplete</b> or <b>not attempted</b>	Assessment standards planned for in the assessment task are <b>attempted but are not correct</b> or the task is <b>incomplete</b> or <b>not attempted</b>	Assessment standards planned for in the assessment task are <b>attempted but are not correct</b> or the task is <b>incomplete</b> or <b>not attempted</b>
Work is at a complex level for the Grade	Work is at an advanced level for the Grade	Work is at an appropriate level for the Grade	Work is mostly at the appropriate level for the Grade	Work is partially at the appropriate level for the Grade	Work is at a very basic level, below grade level	Work reflects poor understanding	Work is at a very basic level, below grade level	Work reflects poor understanding
Has demonstrated total independence when using a range of skills accurately	Has demonstrated confidence when using skills accurately	Has demonstrated a substantial range of skills accurately	Has demonstrated an adequate range of skills accurately	Has demonstrated a moderate range of skills accurately	Has demonstrated a limited range of skills accurately	Is lacking in skills	Has demonstrated a moderate range of skills accurately	Is lacking in skills
Understands and applies all knowledge to solve problems creatively and innovatively	Understands and applies all knowledge to solve problems innovatively	Understands and applies all knowledge to solve problems	Understands most of the knowledge as applied to solve problems	Understands the knowledge as applied to solve problems	Has some understanding of the knowledge as applied to solve problems	Has very little understanding of the knowledge applied to solve a problem	Has superficial understanding of the knowledge applied to solve a problem	Has very little understanding of the knowledge applied to solve a problem
An independent worker	An independent worker needing conformation only	An independent worker needing little assistance	Seldom needs assistance from teachers and peers	Needs some assistance from teachers and peers	Needs some assistance from teachers and peers	Lacks confidence to work on his/her own	Needs regular assistance from teachers and peers	Lacks confidence to work on his/her own
An accurate and complete understanding of the use of complex information and data	An accurate understanding of the use of advanced information and data	Reflects substantial understanding of the use of adequate information and data	Reflects understanding of the use of adequate information and data	Reflects little difficulty in working with elementary forms of information and data	Finds little difficulty in working with elementary forms of information and data	Reflects serious misconceptions when working with information and data	Finds difficulty in working with various forms of elementary information and data	Reflects serious misconceptions when working with information and data
Uses complex technologies independently	Uses advanced technologies independently	Uses a range of appropriate technologies independently	Uses a range of technologies with little assistance	Uses a range of technologies with some assistance	Uses a range of technologies with some assistance	Needs consistent conformation of progress when using technologies	Needs consistent conformation of progress when using technologies	Has no confidence when using technologies
Is producing a highly effective standard of work at a complex level	Is producing a highly effective standard of work at an advanced level	Is producing an effective standard of work at an appropriate level	Is producing an effective standard of work but not always at the appropriate level	Is producing a moderately effective standard of work at the appropriate level	Is producing a moderately effective standard of work at the appropriate level	Work is of an inefficient standard, immediate improvement needed	Work is effective but at a basic level and not at the appropriate grade	Work is of an inefficient standard, immediate improvement needed



# Generic Rubric for assessment of a project

TECHNOLOGY NAME OF LEARNER: _____ CLASS: ____											
TITLE OF THE PROJECT: _____ DATE: ____											
FORM OF ASSESSMENT: PROJECT											
LEVELS OF PERFORMANCE											
CRITERIA	<table border="1" style="width: 100%; border-collapse: collapse;"> <thead> <tr> <th style="width: 10%; padding: 5px;">Highly effective</th> <th style="width: 10%; padding: 5px;">Most areas are effective</th> <th style="width: 10%; padding: 5px;">Some areas are effective</th> <th style="width: 10%; padding: 5px;">Not effective</th> <th style="width: 10%; padding: 5px;">Score</th> </tr> </thead> <tbody> <tr> <td style="padding: 5px;">                     5, 4                      Highly developed in the skill of finding out things, reflected by:                     <ul style="list-style-type: none"> <li>• An ability to critically analyse situations, briefs, scenarios, etc. so as to identify possible problems, needs or opportunities and articulate this clearly.</li> <li>• An ability to access detailed information by using a range of skills like: analysing existing products, doing practical testing procedures and using suitable technologies to locate, collect, present and compare information.</li> </ul> </td> <td style="padding: 5px;">                     3                      Good skills of finding out things, reflected by:                     <ul style="list-style-type: none"> <li>• An ability to analyse situations, briefs, scenarios, etc. so as to identify possible problems, needs or opportunities and state findings.</li> <li>• An ability to access information by using a range of skills like analysing existing products, doing practical testing procedures and using suitable technologies to locate, collect, present and compare information.</li> </ul> </td> <td style="padding: 5px;">                     2                      Skills of finding out things are reflected by:                     <ul style="list-style-type: none"> <li>• A basic ability to analyse situations, briefs, scenarios, etc. and a need to be prompted about possible problems, needs or opportunities.</li> <li>• An ability to access information by using a some of the skills like analysing existing products, doing practical testing procedures and using suitable technologies to locate, collect, present and compare information.</li> </ul> </td> <td style="padding: 5px;">                     1, 0                      Very basic or lack of skills of finding Out things are reflected by:                     <ul style="list-style-type: none"> <li>• An inability to analyse, that results in a constant need to be prompted about possible problems, needs or opportunities.</li> <li>• An inability to access information by using skills like analysing existing products, doing practical testing procedures and using suitable technologies to locate, collect, present and compare information.</li> </ul> </td> <td style="padding: 5px;">                     / 15                 </td> </tr> </tbody> </table>	Highly effective	Most areas are effective	Some areas are effective	Not effective	Score	5, 4 Highly developed in the skill of finding out things, reflected by: <ul style="list-style-type: none"> <li>• An ability to critically analyse situations, briefs, scenarios, etc. so as to identify possible problems, needs or opportunities and articulate this clearly.</li> <li>• An ability to access detailed information by using a range of skills like: analysing existing products, doing practical testing procedures and using suitable technologies to locate, collect, present and compare information.</li> </ul>	3 Good skills of finding out things, reflected by: <ul style="list-style-type: none"> <li>• An ability to analyse situations, briefs, scenarios, etc. so as to identify possible problems, needs or opportunities and state findings.</li> <li>• An ability to access information by using a range of skills like analysing existing products, doing practical testing procedures and using suitable technologies to locate, collect, present and compare information.</li> </ul>	2 Skills of finding out things are reflected by: <ul style="list-style-type: none"> <li>• A basic ability to analyse situations, briefs, scenarios, etc. and a need to be prompted about possible problems, needs or opportunities.</li> <li>• An ability to access information by using a some of the skills like analysing existing products, doing practical testing procedures and using suitable technologies to locate, collect, present and compare information.</li> </ul>	1, 0 Very basic or lack of skills of finding Out things are reflected by: <ul style="list-style-type: none"> <li>• An inability to analyse, that results in a constant need to be prompted about possible problems, needs or opportunities.</li> <li>• An inability to access information by using skills like analysing existing products, doing practical testing procedures and using suitable technologies to locate, collect, present and compare information.</li> </ul>	/ 15
Highly effective	Most areas are effective	Some areas are effective	Not effective	Score							
5, 4 Highly developed in the skill of finding out things, reflected by: <ul style="list-style-type: none"> <li>• An ability to critically analyse situations, briefs, scenarios, etc. so as to identify possible problems, needs or opportunities and articulate this clearly.</li> <li>• An ability to access detailed information by using a range of skills like: analysing existing products, doing practical testing procedures and using suitable technologies to locate, collect, present and compare information.</li> </ul>	3 Good skills of finding out things, reflected by: <ul style="list-style-type: none"> <li>• An ability to analyse situations, briefs, scenarios, etc. so as to identify possible problems, needs or opportunities and state findings.</li> <li>• An ability to access information by using a range of skills like analysing existing products, doing practical testing procedures and using suitable technologies to locate, collect, present and compare information.</li> </ul>	2 Skills of finding out things are reflected by: <ul style="list-style-type: none"> <li>• A basic ability to analyse situations, briefs, scenarios, etc. and a need to be prompted about possible problems, needs or opportunities.</li> <li>• An ability to access information by using a some of the skills like analysing existing products, doing practical testing procedures and using suitable technologies to locate, collect, present and compare information.</li> </ul>	1, 0 Very basic or lack of skills of finding Out things are reflected by: <ul style="list-style-type: none"> <li>• An inability to analyse, that results in a constant need to be prompted about possible problems, needs or opportunities.</li> <li>• An inability to access information by using skills like analysing existing products, doing practical testing procedures and using suitable technologies to locate, collect, present and compare information.</li> </ul>	/ 15							

Designs	Highly developed in the skill of planning reflected by: <ul style="list-style-type: none"> <li>• Ability to state intent explicitly (design brief) and further include quality parameters (specifications)</li> <li>• A good variety of detailed quality alternative solutions.</li> <li>• Well thought out and articulated reasons for choices made.</li> <li>• A detailed and appropriate development of chosen solution.</li> </ul>	Good skills of planning reflected by: <ul style="list-style-type: none"> <li>• Ability to state intent (design brief) and further include parameters (specifications)</li> <li>• A good variety of alternative solutions.</li> <li>• Well thought out and articulated reasons for choices made.</li> <li>• An appropriate development of chosen solution.</li> </ul>	Skills of planning are reflected by: <ul style="list-style-type: none"> <li>• A basic ability to state intent (design brief) and a need to be prompted on parameters (specifications)</li> <li>• Limited solutions (not always alternative)</li> <li>• Reasons for choices made not well thought out or non-existent.</li> <li>• The chosen solution is not well developed.</li> </ul>	Very basic or lack of skills of planning are reflected by: <ul style="list-style-type: none"> <li>• A constant need to be prompted to state intent (design brief) and parameters (specifications)</li> <li>• Little or no alternative solutions.</li> <li>• Absence of reasons for choices</li> <li>• The chosen solution is not well developed.</li> </ul>	/ 20
Makes	Highly developed in the skill of manufacturing reflected by: <ul style="list-style-type: none"> <li>• Manufacturing accurately in line with the design (working drawing)</li> <li>• Made in accordance with the plan of action that was set out; *Any deviation is justified.</li> </ul>	Good skills of manufacturing reflected by: <ul style="list-style-type: none"> <li>*Manufacturing in line with the design (working drawing)</li> <li>• Made in accordance with the plan of action that was set out.</li> </ul>	Skills of manufacturing are reflected by: <ul style="list-style-type: none"> <li>• A basic ability to manufacture in line with the design (working drawing)</li> <li>• Made but not always in accordance with a plan of action.</li> </ul>	Very basic or lack of skills of manufacturing are reflected by: <ul style="list-style-type: none"> <li>• Manufacturing that reflects little or no correlation to the design (working drawing)</li> <li>• Is made without a plan of action.</li> </ul>	/ 15
Evaluates	Highly developed in the skill of evaluating reflected by: <ul style="list-style-type: none"> <li>• Logical thought out evaluating based on detailed criteria.</li> <li>• Appropriate testing procedures carried out where necessary.</li> <li>• Explanations, justifications support findings throughout the process.</li> </ul>	Good skills of evaluating reflected by: <ul style="list-style-type: none"> <li>• Well thought out evaluating based on criteria.</li> <li>*Appropriate testing procedures carried out where necessary.</li> <li>• Adequate explanations, justifications to support findings.</li> </ul>	Skills of evaluation are reflected by: <ul style="list-style-type: none"> <li>• A basic ability to evaluate using criteria; sometimes evaluating without criteria.</li> <li>• Basic or inappropriate testing procedures.</li> <li>• Some or no explanations, justifications to support findings.</li> </ul>	Very basic or lack of evaluation skills of Reflection are reflected by: <ul style="list-style-type: none"> <li>• Evaluation is not done or is inappropriate</li> <li>• No evidence of testing procedures.</li> <li>• The absence of any explanations or justifications.</li> </ul>	/ 10

Communicates	Highly developed in the skill of Presentations reflected by: <ul style="list-style-type: none"> <li>• An excellent understanding of graphical techniques.</li> <li>• The use of appropriate method/s of presentation.</li> <li>• Presentation of work is in a logical sequence.</li> </ul>	Good skills of Presentations reflected by: <ul style="list-style-type: none"> <li>• A good understanding of graphical techniques.</li> <li>• The use of acceptable method/s of presentation.</li> </ul> Presentation of work is mostly in a logical sequence.	Skills of Presentations are reflected by: <ul style="list-style-type: none"> <li>• A basic understanding of graphical techniques.</li> <li>• Method/s of presentation are not always appropriate.</li> <li>• Presentation of work is not always in logical sequence.</li> </ul>	Very basic or lack of Skills of Presentations are reflected by: <ul style="list-style-type: none"> <li>• Little or no understanding of graphical techniques.</li> <li>• Inappropriate method/s used in presentation.</li> <li>• Presentation of work is not in any logical sequence.</li> </ul>	/ 15
Technological knowledge and understanding	Demonstrates an accurate understanding and can apply appropriate knowledge accurately at a complex level.	Demonstrates an accurate understanding and can apply appropriate knowledge accurately at the appropriate level.	Demonstrates some understanding and can apply knowledge partially at the appropriate level.	Demonstrate little understanding of knowledge at a level lower than the appropriate level.	/ 15
Technology, society and the environment	Shows accurate evidence of having considered all the relevant factors that impact on the inter-relationship between science, technology, society and the environment at a complex level.	Shows accurate evidence of having considered relevant factors that mostly impact on the inter-relationship between science, technology, society and the environment at an appropriate level.	Shows some evidence of having considered factors that partially impact on the inter-relationship between science, technology, society and the environment at an appropriate level.	Shows little evidence of having considered factors that impact on the inter-relationship between science, technology, society and the environment at a level lower than the appropriate level.	/ 10
COMMENT:					/100

LEARNER: \_\_\_\_\_ PARENT: \_\_\_\_\_ TEACHER: \_\_\_\_\_ Date: \_\_\_\_\_

# Formal Assessment Task 1

## Test A

Level 1 – lower level multiple-choice: Put a circle around the correct answer

- Magnetism is:
  - The ability for metals to change
  - The ability of a material to exert a force on certain other materials
  - The ability for a material to move from one side to the other[1]
- The Earth has its own:
  - Magnetic field
  - Magnet
  - Field[1]
- When you did the experiment to show the magnetic field you used:
  - A horseshoe magnet
  - Iron rods
  - Iron filings[1]
- An electromagnet is:
  - A bar magnet on a string
  - A switch on a circuit
  - A tightly wound coil of wire[1]
- Circle the materials that are attracted to magnets:
  - Wood, plastic, fabric
  - Paper, glass, magazine
  - Iron, steel, nickel[1]
- Look at the simple circuit diagram below and circle the correct word to label the part: [4]

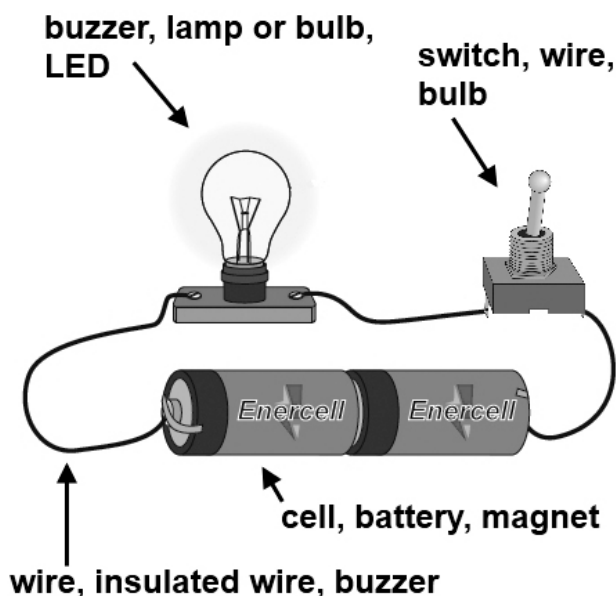

- An input device that is a source of energy is:
  - An insulated wire
  - A bell
  - A cell[1]

8. A control device which allows current to flow in one direction only, and emits light, is:  
 (a) A cell  
 (b) An LED – light emitting diode  
 (c) A battery [1]
9. An output device that gives off sound when a current passes through it is:  
 (a) A cell  
 (b) A battery  
 (c) A bell [1]
10. The crank is:  
 (a) An adaptation of a second-class lever  
 (b) An adaptation of a wheel  
 (c) An adaptation of a pulley [1]
11. Which sentence describes mechanical advantage?  
 (a) It is a machine that makes life easier for us.  
 (b) It is a light that switches on.  
 (c) It is load between the pivot and the effort. [1]
12. Draw a frame structure and label it. [6]

**Test B**

1. Describe the different types of magnet that you can get. Give three examples. [3]
2. What is a frame structure? Give three examples. [3]
3. Draw the symbols for these components and say what they are used for. Fill in the table below:

Name	Picture	Symbol	Use
Battery			
Switch			
Bell			
Buzzer			
LED			

[16]

4. Draw the circuit diagram neatly for the circuits below: [15]

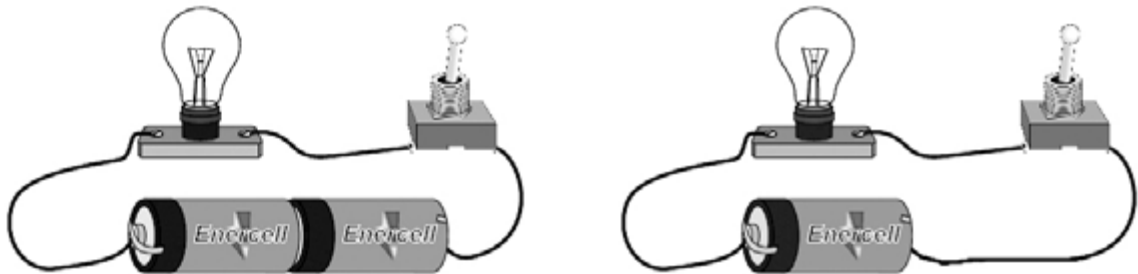

5. Explain in detail how to make any pulley system. [3]

### Test C:

1. Write down the different mechanical systems used in a crane with an electromagnet. [10]
2. Give examples of where you would use these lines when drawing your design:
  - (a) chain line
  - (b) a continuous thin line – freehand
  - (c) a thick dashed line
  - (d) a continuous thin line. [8]
3. Draw a circuit for an electromagnet, and include the circuit diagram. [10]
4. Describe magnetism. [2]
5. Write a paragraph about recycling and why you think you should do it in your community. [10]
6. What is mechanical advantage? Give four different items or machines that give us mechanical advantage in our homes. [10]
7. Draw and label any crank. Describe how it works. [5]
8. Draw any pulley system. Describe how it works. [5]
9. Describe in your own words what an oblique drawing is and where you would use it in your design. [10]
10. Draw a simple flow chart showing how you would make a simple circuit. [10]
11. Design a simple poster promoting the simple circuit. [10]
12. Describe the experiment showing the magnetic field of a bar magnet. [10]
13. Write a paragraph on how to strengthen a crane when building it. Think of as many different ways as possible. [10]

Total: [170]

## Formal Assessment Task 1: Memorandum







**Possible answers:**

**Test A:**

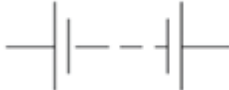
1. (b)
2. (a)
3. (c)
4. (c)
5. (c) [5]
6. Bulb or lamp, insulated wire, cell, switch. [4]
7. (c)
8. (b)
9. (c)
10. (a)
11. (a)
12. The learner will draw a frame structure. [11]

**Test B:**

1. The three types of magnet are permanent, temporary and electromagnet. [3]
2. A frame structure is a structure that is joined together to make a framework. Examples of frame structures are: a ladder, chair, electrical pylon, burglar guards, some bridges, TV aerial, bicycle frame. [3]
3. [16]

Name	Picture	Symbol	Use
Battery			Input device: source of energy for longer
Switch			Control device: used to temporarily close a circuit, such as a door bell
Bell and buzzer			Output device - vibrates to give off sound when current passes through it - useful as an alarm.
LED			Control device - allows current to flow in one direction only, and emits light.

4. Illustration of a circuit with two cells joined in series with a switch and a light bulb. Another illustration of a circuit with a switch and a cell with the light bulbs joined in series. [15]
5. How to make a pulley system: Use two wheels with a piece of string. The wheels must be attached to something a short distance apart. The 'wheels' will be better if they have grooves in them for the string to stay in place. [3]

## Test C:

### Possible answers

1. Different mechanical systems used in the crane are: an electromagnet, pulley systems, crank system, and electrical system. [10]
2. Continuous thin line, visible outlines, and visible edges. They could be used when designing the features of the crane, Hidden outlines, and Thick dashed line. This shows the part that you cannot see in the design but it is important to have it there so the person looking at the design can see what will be happening at the 'back' of the drawing: Continuous thin line, Hidden outlines Hidden edges. These limit partial views. [8]
3. An illustration of the circuit for an electromagnet with the parts. These should be labelled.

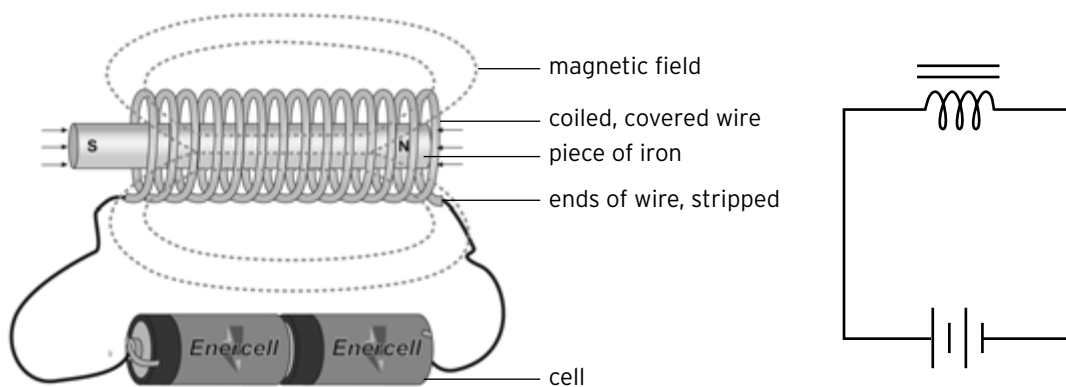

[10]

4. Magnetism is the ability of a material to exert a force upon certain other materials. [2]
5. The world is producing more and more waste materials. The dumping grounds are becoming full. A great deal of litter is making its way into the rivers and oceans and is killing of wildlife and fish. The environment is being destroyed. We need to start sorting our waste materials and re-use it or sell it to people who can re-use it. It is not only a few people who should do this, we as a community should do this and teach others in our community how to recycle. If the community collects the right materials they can also make some money from the project. Sorting and re-using materials it is also a way of cleaning up the neighbourhood. The waste materials can be collected in bins and sorted for re-use or collecting. Waste food, vegetable and fruit off cuts can be used in the garden for fertiliser. It can be dug into the soil to put back nourishment. [10]
6. Mechanical advantage is when a machine makes our lives and our work easier. Types of machines that give us mechanical advantage are: a washing machine, pop up toaster, egg beater, vacuum cleaner, fan, bicycle and sewing machine. [10]
7. A crank is a second-class lever. It works with the load being between the pivot or fulcrum and the effort. Learners draw a crank of their choice. [5]
8. The pulley is a type of wheel and axle mechanism. It is used to lift a heavy load or it is used to change the direction of a tension force. Learners draw a pulley of their choice. [5]



9. An oblique drawing is a drawing that you use to draw your design ideas. It is another form of pictorial representation. One face or side of an object is drawn in its true shape and the other part of the object is drawn sloping away. The oblique drawings have three axes: one is vertical, one is horizontal and one is inclined. [10]
  10. This answer should show a drawing of a flow chart showing how to make a simple circuit. This should include a flow chart starting with the cell, then a line that leads to insulated wires, attaching the bulb and attaching the switch. [10]
  11. For this the learners will create a drawing of the simple circuit using bright colours. It will be labelled with content about what parts were used and how easy or difficult it is to make. [10]
  12. Learners describe the experiment showing the magnet field using a bar magnet. [10]
  13. How to strengthen a crane: Use triangulation in the tower of the crane. Triangles are the strongest shape, so the tower of the crane can be built with different sized triangles that are joined well. The crane can also be stabilised with struts and guys. [10]
- Total: [170]

# Group Assessment Rubric of design briefs

## Appendix 1

Date: \_\_\_\_\_

Type of **Assessment**: Peer Assessment

Group Members:

1 \_\_\_\_\_

2 \_\_\_\_\_

3 \_\_\_\_\_

4 \_\_\_\_\_

5 \_\_\_\_\_

Criteria	Learner 1	Learner 2	Learner 3	Learner 4	Learner 5
Brief takes into account refugee situation					
Specifications are practical					
Ingredients are cheap and readily available					
Equipment needed is easy to use and obtainable					
<b>Total Score</b>					

### Key:

5 – Excellent

4 – Very good

3 – Good

2 – Room for improvement

1 – More effort required

## Assessment Rubric for preparing the meal

### Appendix 2

(LB. p. 141, Lesson 6 Activity 7)

Date: \_\_\_\_\_

Type of Assessment: Observation

Assessor: Educator

Criteria	Group A	Group B	Group C	Group D	Group E
Simplicity of cooking method					
Economical/ingredients cheap and easy to obtain					
Attention to hygiene					
Safety factors considered					
Practical choice of utensils taking situation into account					
Good time management skills					
Group well organised/evidence of good planning					
Additional effort					
Total					

### Key:

5 – Excellent/very well prepared/excellent organisational skills/much additional effort included

4 – Very good/well prepared/good team work/evidence of additional effort included

3 – Good/well organised/all criteria considered

2 – Meets basic requirements/some team effort/time management could improve

1 – Very little effort included/poor team work and organisational skills

0 – Disappointing/no effort made

## Assessment Rubric for the Taste Panel

### Appendix 3

(LB. p. 142, Lesson 6 Activity 8) Extension Activity

Date: \_\_\_\_\_

Type of Assessment: Peer –Taste Panel

Name of Judge: \_\_\_\_\_

Group: \_\_\_\_\_

Criteria	Group A	Group B	Group C	Group E	Group F
Taste					
Texture					
Appearance					
Presentation					
Total					

#### Key:

5 – Excellent

4 – Very good

3 – Good

2 – Can improve

1 – 0 – Little or no effort made

Assessment Rubric for the Taste Panel (LB. p. 141, Lesson 6 Activity 8)

Extension Activity

Date: \_\_\_\_\_

Type of Assessment: Peer –Taste Panel

Name of Judge: \_\_\_\_\_

Group: \_\_\_\_\_

Criteria	Group A	Group B	Group C	Group E	Group F
Taste					
Texture					
Appearance					
Presentation					
Total					

#### Key:

5 – Excellent

4 – Very good

3 – Good

2 – Can improve

1 – 0 – Little or no effort made

# Planning Sheet

## Appendix 4

Lesson 12 ACTIVITY 18

Date: \_\_\_\_\_

Group Members:

_____	_____
_____	_____
_____	_____

Best Choice:

\_\_\_\_\_

Reasons for our choice

\_\_\_\_\_  
\_\_\_\_\_  
\_\_\_\_\_

Design Specification Sheet:

Resources and Equipment Needed

\_\_\_\_\_  
\_\_\_\_\_  
\_\_\_\_\_  
\_\_\_\_\_

Allocation of duties

Members Name	Task	Equipment, resources responsible for

# Assessment Rubric - PAT - Shelter for refugees

**Appendix 5 LB p.152, Lesson 13 and 14**

Group Members:

Marks \_\_\_\_\_

\_\_\_\_\_

\_\_\_\_\_

\_\_\_\_\_

\_\_\_\_\_

\_\_\_\_\_

	Criteria	Score/5
1	Suitability of material	
2	Easy to transport	
3	Easy to assemble	
4	Easy to pack and unpack	
5	Construction	
6	Aesthetic value	
7	Organisational Skills	
8	Team work	
9	Time management	
10	Additional effort	
	Total	

**Key**

- 5 – All specifications taken into account/planning and organisational skills are excellent/ excellent evidence of research/solution is practical and very creative with much additional effort included.
- 4 – Most specifications taken into account/planning and organisational skills are very good/ good evidence of research/solution is practical and creative, evidence of additional effort included.
- 3 – Specifications considered/evidence of planning and organising work/some evidence of research/solution is practical. Very little additional effort included.
- 2 – Specifications not taken into account/planning and organisational skills need to improve/ no evidence of research/solution is practical but hampered by poor time management skills
- 1 – Poor planning and organisational skills/no evidence of research/solution is not sturdy, durable or practical little effort included.
- 0 – No effort made/very little planning/poor organisational skills/very little team work

Educator Comment: \_\_\_\_\_

\_\_\_\_\_

\_\_\_\_\_

Educator Signature: \_\_\_\_\_

Date: \_\_\_\_\_

# Investigative Task Worksheet

Type of food that can be served to people living in a refugee camp

Date: \_\_\_\_\_

Group members:

- 1 \_\_\_\_\_
- 2 \_\_\_\_\_
- 3 \_\_\_\_\_
- 4 \_\_\_\_\_
- 5 \_\_\_\_\_

Source where information is obtained from: \_\_\_\_\_

	List of suitable foods	Criteria								
		Availability of food	Nutritional value	Simplicity of cooking methods	Suitability of meal preparation time	Cost	Can it be served on its own?	Feeds a reasonable number of people	Requires simple storage facilities	
1	Brown bread	✓	✓	✓	✓	✓	✓	✓	✓	
2										
3										
4										
5										
6										
7										
8										
9										

Learner Signature \_\_\_\_\_  
Date \_\_\_\_\_

Educator Signature \_\_\_\_\_  
Comment \_\_\_\_\_

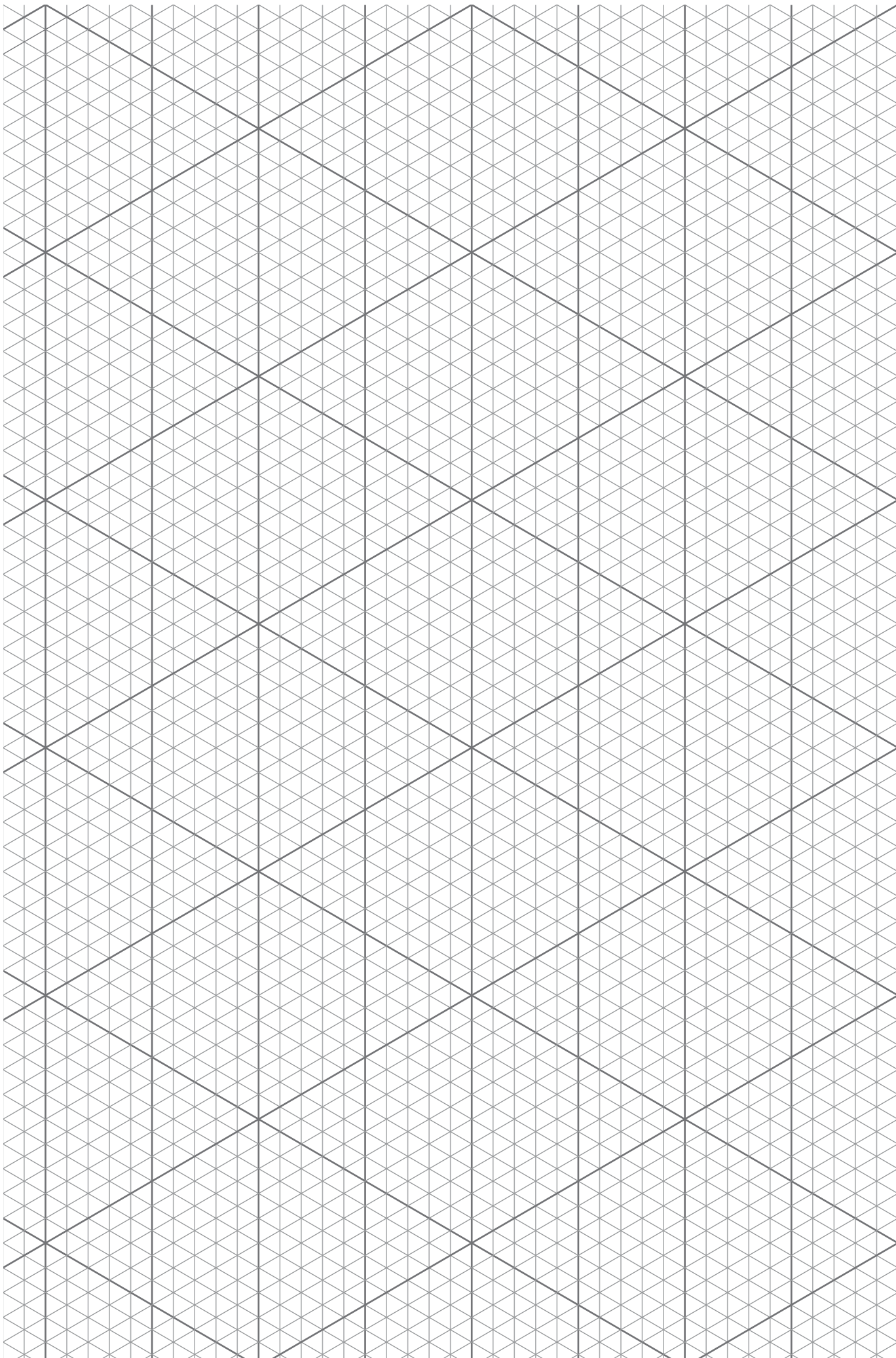



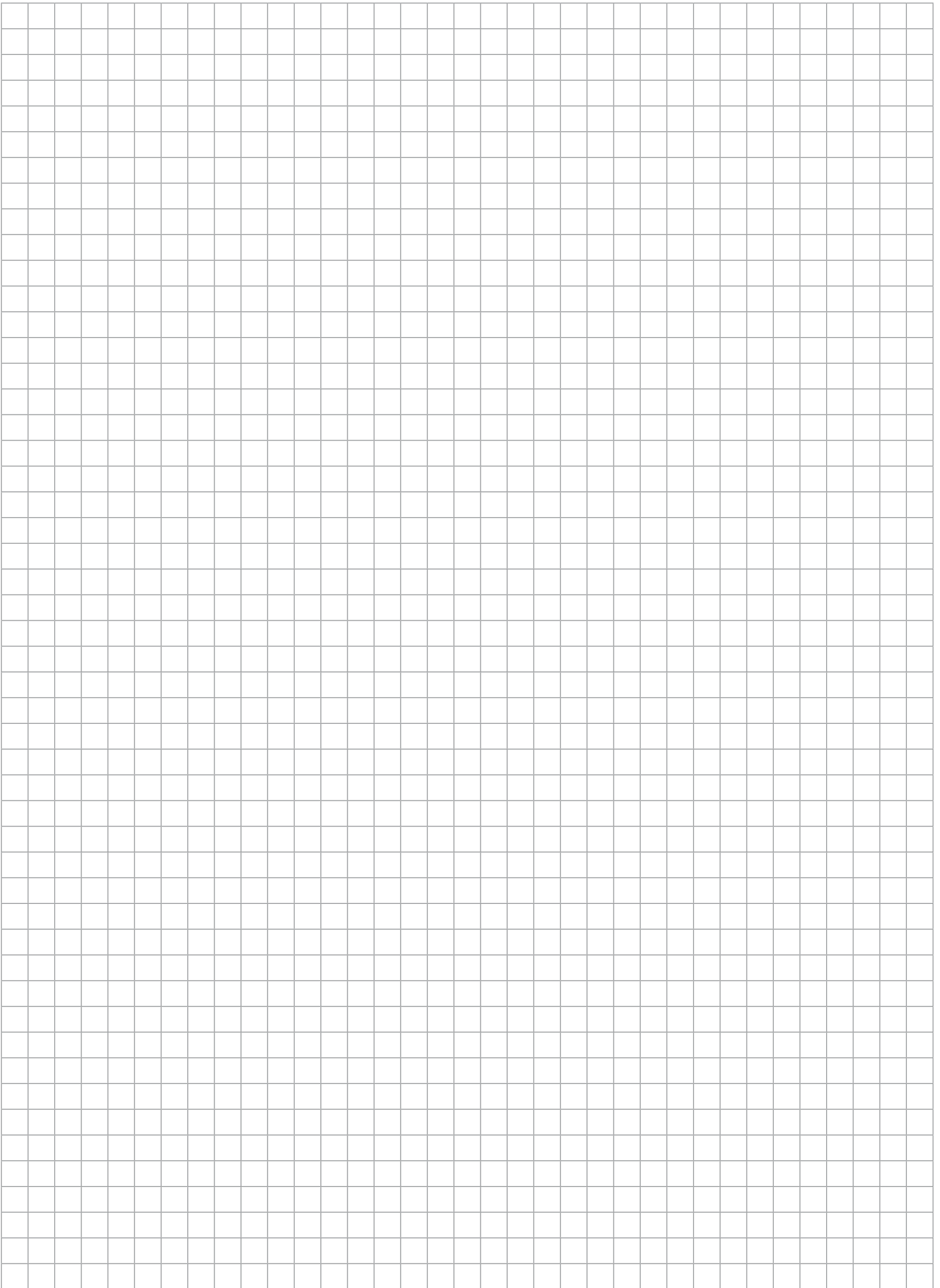

# Section F: Documents



This section is for you to file your copy of the Curriculum and Assessment Policy Statement (CAPS) for Technology in the Senior Phase.

**Guidelines to strengthen CAPS**

**F3**

---

---

---

---

---

You may add any other documents you receive in this section and list them above for easy reference.



## **Guidelines to strengthen CAPS**

Please note that from 2017 the Department of Basic Education (DBE) has made changes to the Formal assessment requirements for Technology Grade 7 to 9. Refer to **Formal assessment** in **Section C – Assessment, page C6 to C14** and make the following changes:

- Reduce Mini-PAT to two per year and the second Mini-PAT should be done in the third Term (i.e. there will be no Mini-PAT/PAT in the second term)
- Use the Basic Minimum resources document to procure the resources
- Use the IDMEC (Investigate, Design, Make, Evaluate, and Communicate) process per Term. For example, the formal assessment tasks for Term 1 can include an Investigation task and a Communication task or a combination of any of the components of the IDMEC process
- Ignore the 5+5+5+5 = 20 allocation
- Change “Mini-PAT” to “PAT”.

Grade

7

# Study & Master

## Technology

This *Study & Master Technology* course has been updated. The course has been specially developed by experienced educators to meet all the requirements of the Curriculum and Assessment Policy Statement (CAPS). This easy-to-use course not only helps learners master essential content and skills in the subject but gives them the best possible foundation on which to develop and build their Technology knowledge and understanding.

The comprehensive Learner's Book:

- provides an overview of content, concepts and skills covered in each term
- provides activities that develop learners' skills and understanding of each of the topics specified by the CAPS Technology curriculum
- includes investigations, and practical tasks, as well as Informal and Formal Assessment Tasks
- features 'Did you know?' boxes with interesting additional information and 'Safety tip' and hint boxes that provide guidance on how to do technology tasks safely and easily
- includes a glossary of key words to help with the understanding of new terms and concepts.

The innovative Teacher's Guide includes:

- an expanded contents page and a work schedule for the year
- guidance on the teaching of each lesson and on each form of assessment
- step-by-step support in the teaching of activities and the carrying out of practical tasks
- photocopiable record sheets and templates, as well as additional worksheets to support your teaching.

**Ria de Jager** obtained a Masters Degree in Technology Education. She was Deputy Chief Education Specialist in Technology at the KZN DoE and Chairperson of the Technology Association of SA. **Lin Bassett** has taught Technology at both government and private schools and presented various workshops at Technology conferences. **Barbara Munsami** is subject head (Technology) at Marist College and has facilitated workshops for both NGOs and the DBE. **Lynn Pocock** has trained in Technology teaching methods, taught at a pilot school for Technology and has been working in Special Needs and Remedial Schools for over a decade. **Neel Ramdutt** has an MEd in Educational Studies and Multimedia Design as well as a Certificate in Technology Education. He is Deputy Chief Education Specialist (Technical Subjects/Technology) at the KZN DoE.

